

REQUEST FOR PROPOSALS
By the City of Homer, Alaska
To Lease City Property on the Homer Spit

AUG - 8 2014



The City of Homer, Alaska is requesting proposals from individuals or firms to lease one or more of the eleven City-owned parcels located on the Homer Spit in Homer, Alaska. All Lots Offered Separately. The proposals that satisfy all minimum requirements and scores best on the City's evaluative criteria will be offered the opportunity to negotiate for a lease with the City. The parcels that are available are:

| | | |
|----------|---------|--|
| Parcel A | Lot 9A | Homer Spit Replat 2006 on Fish Dock Road |
| Parcel B | Lot 10A | Homer Spit Replat 2006 on Fish Dock Road |
| Parcel C | Lot 4 | Homer Spit Subdivision, No. 5 on Freight Dock Road |
| Parcel D | Lot 5 | Homer Spit Subdivision, No. 5 on Freight Dock Road |
| Parcel E | Lot 6 | Homer Spit Subdivision, No. 5 on Freight Dock Road |
| Parcel F | Lot 7 | Homer Spit Subdivision, No. 5 on Freight Dock Road |
| Parcel G | Lot 8 | Homer Spit Subdivision, No. 5 on Freight Dock Road |
| Parcel H | Lot 9 | Homer Spit Subdivision, No. 5 on Freight Dock Road |
| Parcel I | Lot 10 | Homer Spit Subdivision, No. 5 on Freight Dock Road |
| Parcel J | Lot 11 | Homer Spit Subdivision, No. 5 on Freight Dock Road |
| Parcel K | Lot 12 | Homer Spit Subdivision, No. 5 on Freight Dock Road |

Proposals to the City's request will be received at the City Clerk's Office, 491 E. Pioneer Avenue, Homer, Alaska 99603, until 4:30 p.m. Thursday, August 28, 2014 at which time they will be logged in and provided to the City Lease Committee. A non-refundable lease application fee of \$30 must be submitted with the proposal. Proposals received after the time specified or proposals received from proposers not listed on the plan holders list will be considered non-responsive and shall not be considered.

Plan holder registration forms, and Plans and Specifications are available on line at <http://www.cityofhomer.ak.gov/rfps>. All proposers must submit a City of Homer Plan Holders Registration form to be on the Plan Holders List and to be considered responsive. To obtain a copy of the proposal package and to be listed on the plan holders list, contact: Office of the City Clerk, 491 E. Pioneer Avenue, Homer, AK 99603, (907) 235-3130, clerk@ci.homer.ak.us.

To arrange to view or inspect any parcel, or for information regarding existing utility lines or the fish outfall line and connections, contact: Bryan Hawkins, Port and Harbor Director/Harbormaster, 4350 Homer Spit Road, Homer, Alaska 99603, (907) 235-3160, bhawkins@ci.homer.ak.us.

The City reserves the absolute right to reject any or all proposals, may waive any or all informalities or irregularities, and may permit the correction of errors or omissions in responses.

Dated this 8th day of August 2014.

City of Homer



Walt Wrede, City Manager

Publish: Homer News 8/14/14 & 8/21/14
Account #: 400-0600-5227

CURVE TABLE

| CURVE | DELTA | RADIUS | LENGTH | CHORD BRNG | CHORD DIST |
|-------|-----------|--------------|-----------------------|---------------|------------|
| C1 | 49°28'20" | 359.26'(M&R) | 310.20'(M) 310.04'(R) | N 79°08'26" E | 300.65' |
| C2 | 44°17'02" | 359.26' | 277.67' | S 81°44'05" W | 270.81' |
| C3 | 5°11'18" | 359.26' | 32.53' | S 56°59'55" W | 32.52' |
| C4 | 66°06'32" | 409.26' | 472.21' | N 87°27'31" E | 446.45' |

LINE TABLE

| LINE | BEARING | DISTANCE |
|-------|------------------|-----------|
| L1(M) | S 54°24'15" W(M) | 76.68'(M) |
| L1(R) | S 54°29'57" W(R) | 76.99'(R) |

LEGEND

- INDICATES ADH BC MON IN CASE RECOVERED THIS SURVEY
- INDICATES 5/8" REBAR WITH 2" ALCAP (7538-S, 2004) SET THIS SURVEY
- (M) MEASURED DATA
- (R) RECORD DATA

PLAT APPROVAL

THIS PLAT WAS APPROVED BY THE KENAI PENINSULA BOROUGH PLANNING COMMISSION AT THE MEETING OF 2/14/2005

KENAI PENINSULA BOROUGH

BY: Mary Beth
AUTHORIZED OFFICIAL

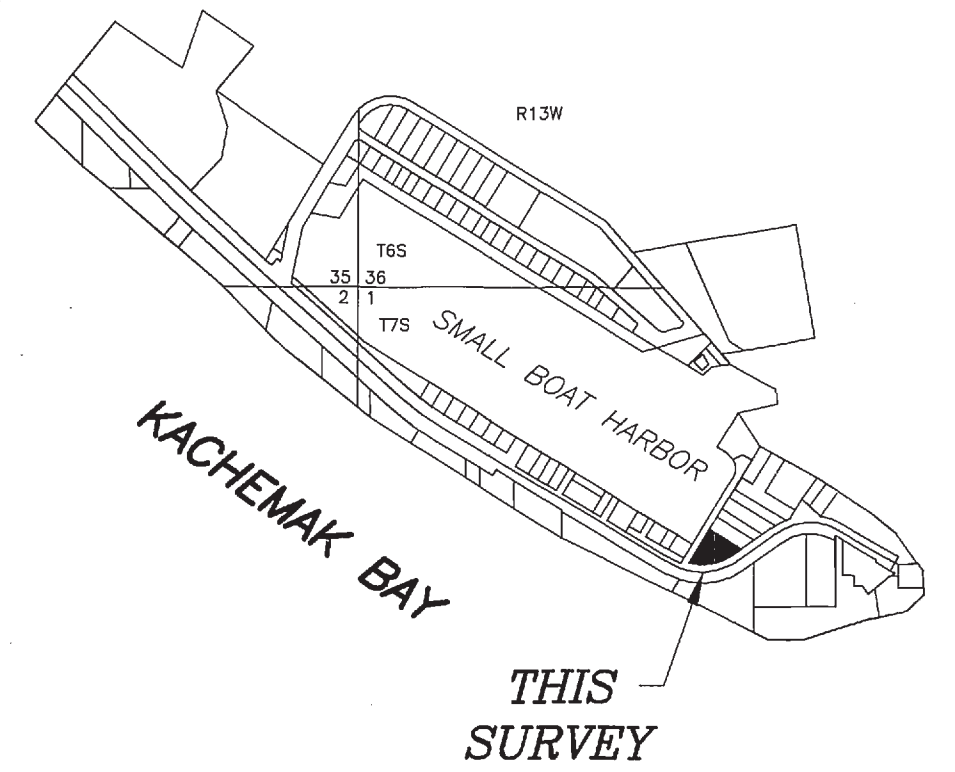

VICINITY MAP

SCALE: 1" = 1,320 FEET

CERTIFICATE OF OWNERSHIP

I HEREBY CERTIFY THAT I AM THE OWNER OF THE REAL PROPERTY SHOWN AND DESCRIBED HEREON, THAT I HEREBY ADOPT THIS PLAT OF SUBDIVISION, AND BY MY FREE CONSENT DEDICATE ALL RIGHTS OF WAY AND PUBLIC AREAS TO PUBLIC USE, AND GRANT ALL EASEMENTS TO THE USE SHOWN HEREON.

Walt Wrede 1/17/07
CITY OF HOMER
WALT WREDE, HOMER CITY MANAGER
491 EAST PIONEER AVENUE
HOMER, ALASKA 99603

NOTARY'S ACKNOWLEDGEMENT

SUBSCRIBED AND SWORN TO BEFORE ME THIS 17th DAY OF January, 2007.

FOR: WALT WREDE
Rachel C. Lunt
NOTARY PUBLIC FOR ALASKA

MY COMMISSION EXPIRES May 5, 2010

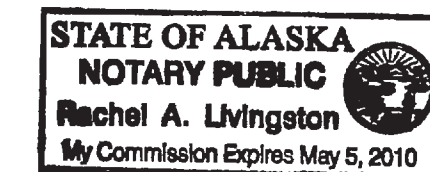

HOMER RECORDING DISTRICT

HOMER SPIT REPLAT 2006
A REPLAT OF LOTS 9, 10 AND 11 OF THE CITY OF HOMER REPLAT OF A PORTION OF THE HOMER SPIT (HRD 67-444) INTO LOTS 9-A AND 10-A

LOCATED WITHIN THE N. 1/2 OF SEC. 1, T7S, R13W, S.M., AK AND WITHIN THE CITY OF HOMER, ALASKA CONTAINING 1.055 ACRES

GEOVERA, LLC
STEPHEN C. SMITH, P.L.S.
PO BOX 3235
HOMER, ALASKA 99603
(907) 235-0501 FAX 235-9302

| | | |
|---------------|---------------|---------------|
| DRAWN BY: SCS | COMP BY: SCS | JOB #04-14 |
| DATE: 3/13/06 | SCALE: 1"=50' | SHEET #1 OF 1 |

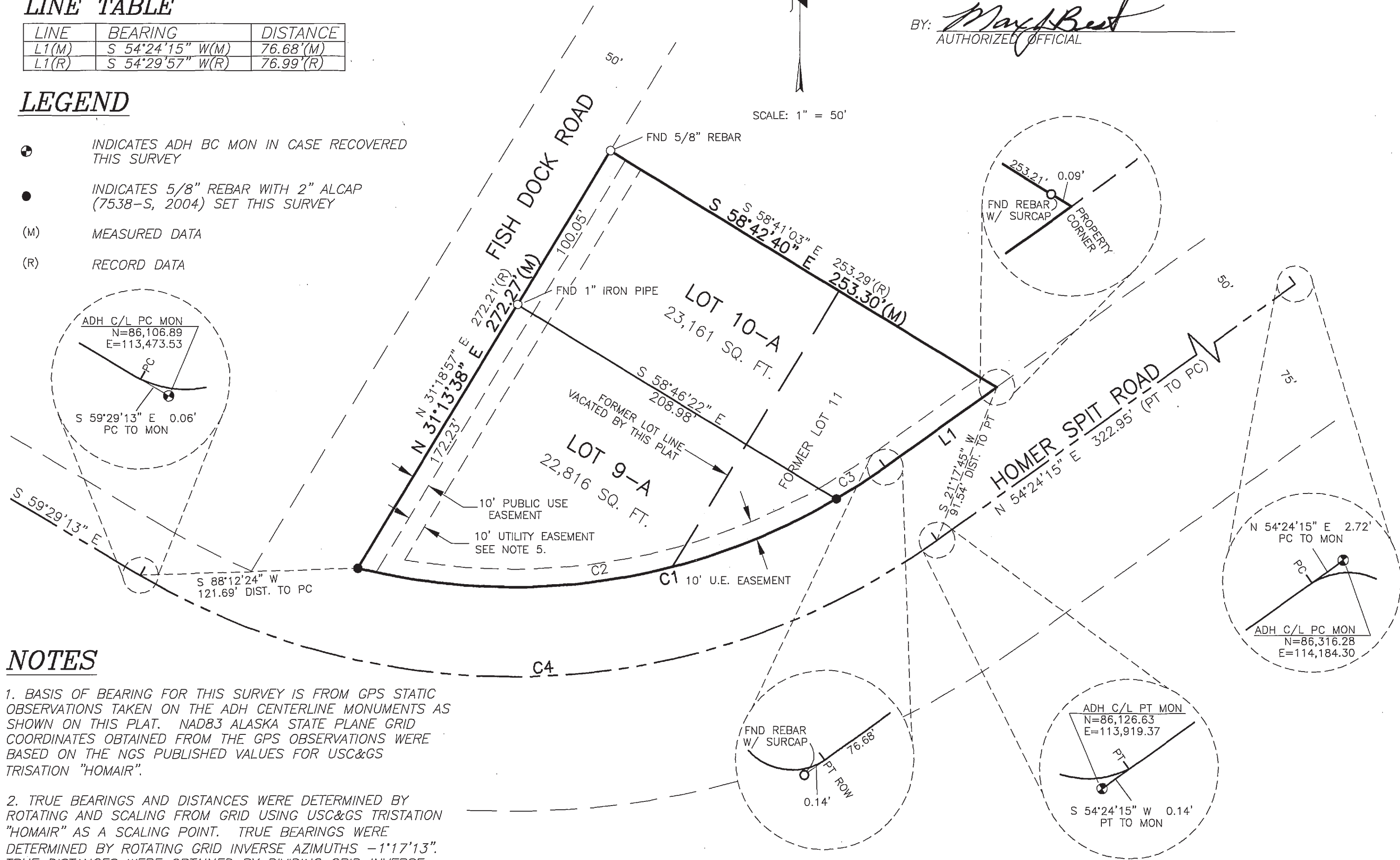

NOTES

- BASIS OF BEARING FOR THIS SURVEY IS FROM GPS STATIC OBSERVATIONS TAKEN ON THE ADH CENTERLINE MONUMENTS AS SHOWN ON THIS PLAT. NAD83 ALASKA STATE PLANE GRID COORDINATES OBTAINED FROM THE GPS OBSERVATIONS WERE BASED ON THE NGS PUBLISHED VALUES FOR USC&GS TRISTATION "HOMAIR".
- TRUE BEARINGS AND DISTANCES WERE DETERMINED BY ROTATING AND SCALING FROM GRID USING USC&GS TRISTATION "HOMAIR" AS A SCALING POINT. TRUE BEARINGS WERE DETERMINED BY ROTATING GRID INVERSE AZIMUTHS -1°17'13". TRUE DISTANCES WERE OBTAINED BY DIVIDING GRID INVERSE DISTANCES BY 0.999986696.
- TRUE COORDINATE VALUES WERE TRANSLATED TO A LOCAL COORDINATE SYSTEM BASED ON N=100,000 E=100,000 AT USC&GS TRISTATION "HOMAIR".
- NO PERMANENT STRUCTURE SHALL BE CONSTRUCTED OR PLACED WITHIN AN EASEMENT WHICH WOULD INTERFERE WITH THE ABILITY OF A UTILITY TO USE THE EASEMENT.
- EXISTING BURIED ELECTRICAL FACILITIES IN THIS AREA ARE CENTERLINE OF A 10 FOOT WIDE ELECTRICAL DISTRIBUTION LINE EASEMENT.
- NO DIRECT VEHICLE ACCESS TO STERLING HIGHWAY IS PERMITTED UNLESS APPROVED BY STATE OF ALASKA, D.O.T.
- EXCEPTION TO KPB 20.20.220: LOTS - DOUBLE FRONTAGE WAS GRANTED IN THEIR MEETING ON 2-14-05.
- AN EASEMENT EXISTS IN FAVOR OF THE DEPT. OF HIGHWAY DATED 4-20-1967, BOOK 44 PAGE 89, H.R.D.
- ALL RECORD DATA IS FROM CITY OF HOMER REPLAT OF A PORTION OF THE HOMER SPIT (HRD 67-444).
- THE PUBLIC USE EASEMENT IS FOR UNDERGROUND UTILITIES AND PEDESTRIAN ACCESS. THE CITY OF HOMER WILL BE THE PARTY RESPONSIBLE FOR ENFORCEMENT OF THE EASEMENT.

WASTEWATER DISPOSAL

PLANS FOR WASTEWATER DISPOSAL, THAT MEET REGULATORY REQUIREMENTS ARE ON FILE AT THE DEPARTMENT OF ENVIRONMENTAL CONSERVATION.

2007-136 20
Homer REC DIST
Date 12/31 2007
Time 12:51 P.M.
Requested By Seabright
Address _____

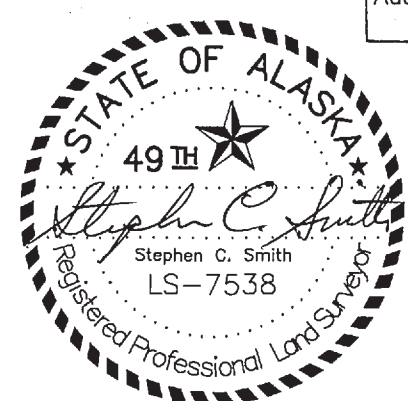

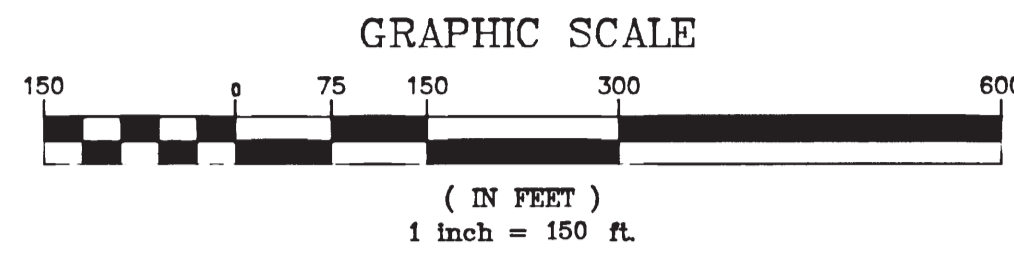

NOTES:
 BASIS OF BEARING IS THE CITY OF HOMER COORDINATE SYSTEM,
 AS SHOWN ON PLAT 87-37RS HRD CITY OF HOMER AREA RECORD
 OF SURVEY, AND REFERENCED ON THE PARENT PLAT 89-34HRD
 All survey monumentation shown is of record. Individual lot corners
 will be established as needed, upon completion of road and utility
 construction and parcel utilization.

ATS-612 (77-64 HRD)

ATS 1373

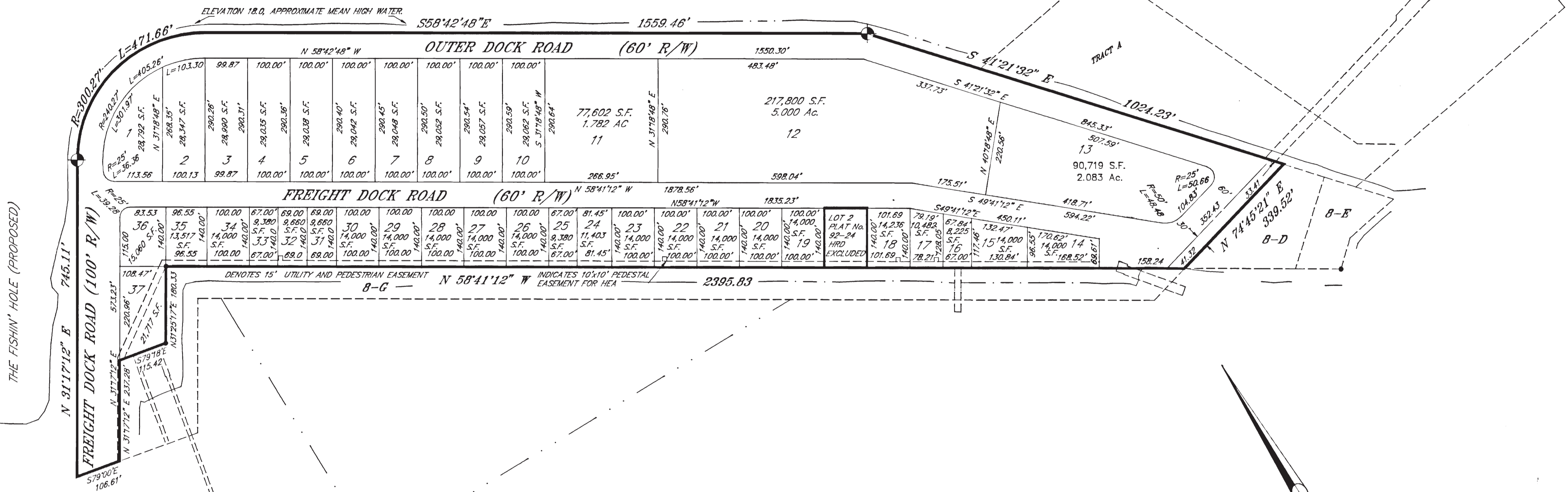

CERTIFICATE OF OWNERSHIP
 I hereby certify that I am the owner of the property
 shown and described hereon. I hereby request approval
 of this plat showing such easements for public utilities
 and roadways dedicated by me for public use, or to the
 uses shown

Richard J. Leland July 21, 1992
 RICHARD J. LELAND DATE:
 HOMER CITY MANAGER
 491 EAST PIONEER AVENUE
 HOMER, ALASKA 99603

NOTARY'S ACKNOWLEDGEMENT
 FOR RICHARD J. LELAND
 JERRY ANDERSON
 NOTARY PUBLIC
 STATE OF ALASKA
 Subscribed and sworn to before me this 21st day
 of July 1992.

Jerry A. Anderson 11-2-95
 Notary Public for Alaska My Commission Expires

SURVEYORS CERTIFICATE
 I hereby certify that this survey was performed by me or
 under my direct supervision. I declare that the information
 shown hereon is true and correct to the best of my
 knowledge and belief.

Jerry A. Anderson 7-21-92
 Jerry A. Anderson PLS No. 3686 Date:

PLAT APPROVAL
 This plat was approved by the Kenai Peninsula Borough
 Planning Commission at the meeting of June 22, 1992
 KENAI PENINSULA BOROUGH
Richard P. Truini
 Authorized Official

VICINITY MAP SCALE: 1" = 1000'

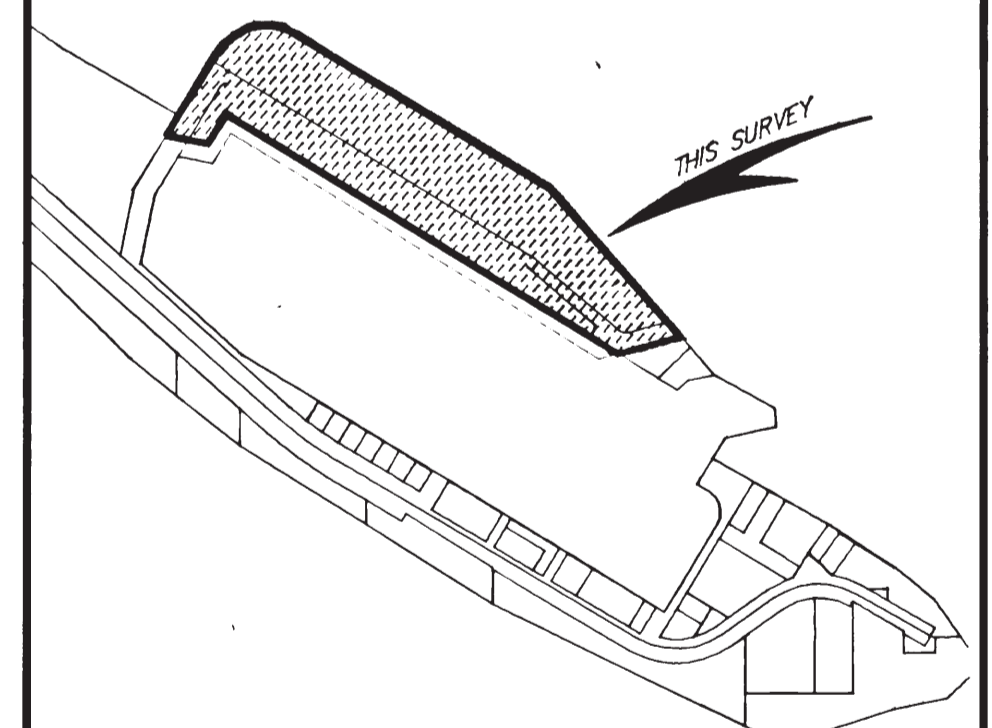

NOTE:
 NO DIRECT ACCESS TO STATE MAINTAINED RIGHTS OF
 WAY IS PERMITTED UNLESS APPROVED BY THE STATE OF
 ALASKA DEPARTMENT OF TRANSPORTATION.
 NO PERMANENT STRUCTURE SHALL BE CONSTRUCTED OR
 PLACED WITHIN AN EASEMENT WHICH WOULD INTERFERE
 WITH THE ABILITY OF A UTILITY TO USE THE EASEMENT.
 THERE IS A 15' UTILITY EASEMENT CENTERED ALONG THE
 EXISTING BURIED CABLE INSTALLED BY HOMER ELECTRIC
 ASSOCIATION. (GENERALLY WITHIN FREIGHT DOCK ROAD R/W)

WASTEWATER DISPOSAL
 THE ALASKA DEPARTMENT OF ENVIRONMENTAL CONSERVATION HAS REVIEWED PLANS
 FOR THIS SUBDIVISION'S WASTEWATER DISPOSAL AND APPROVES THIS SUBDIVISION
 FOR PLATTING.
Dave Johnson EE 8-17-92
 SIGNATURE TITLE DATE

93-12
 RECORDED 20'
 HOMER REC. DIST
 DATE 2-23 93
 TIME 10:52 P.M.
 REQUESTED BY: ABILITY SURVEYS
 ADDRESS: P.O. BOX 378
 HOMER, ALASKA 99603

DATE JUNE 1992
 SCALE 1" = 150'
 GRID No. H1 - H5
 FLD. BK. No. 176
 DISK No. C.1.18 L
 JOB No. 0545

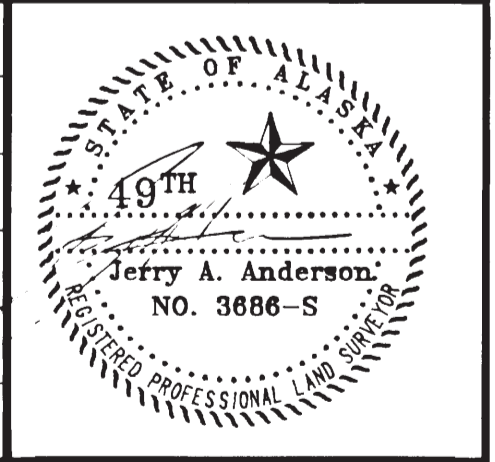

HOMER SPIT No. FIVE
 A REPLAT OF LOTS B-A, B-B AND B-C, HOMER SPIT No. TWO
 AND LOTS 1 AND 3 OF HOMER SPIT No. FOUR
 HOMER RECORDING DISTRICT
 Sec. 35 & 36, Twp. 6S, & Sec. 1, Twp. 7S
 Rge. 13W S.M., WITHIN THE CITY OF HOMER, ALASKA
 CONTAINING 32.939 ACRES

ABILITY SURVEYS
 JERRY A. ANDERSON PLS
 (907) 235-8440
 BOX 378, HOMER ALASKA 99603

KPB FILE No. 92-050

Homer City Code

Chapter 21.30 MI Marine Industrial District

- 21.30.010 Purpose.
- 21.30.020 Permitted uses and structures.
- 21.30.030 Conditional uses and structures.
- 21.30.040 Dimensional requirements.
- 21.30.050 Site and access plan.
- 21.30.060 Traffic requirements.
- 21.30.070 Site development requirements.
- 21.30.080 Nuisance standards.
- 21.30.090 Lighting standards.

21.30.010 Purpose. The purpose of the Marine Industrial District is primarily to provide adequate space for those water-dependent industrial uses that require direct marine access for their operation, such as fishing, fish processing, marine transportation, off-shore oil development and tourism; giving priority to those water-dependent uses over other industrial, commercial and recreational uses. (Ord. 08-29, 2008).

21.30.020 Permitted uses and structures. The following uses are permitted outright in the Marine Industrial District, except when such use requires a conditional use permit by reason of size, traffic volumes, or other reasons set forth in this chapter:

- a. Port and harbor facilities;
- b. Manufacturing, processing and packing of sea products;
- c. Cold-storage;
- d. Dry docks;
- e. Wharves and docks, marine loading facilities, ferry terminals, marine railways;
- f. Marine equipment sales, rentals, service, repair and storage.
- g. Boat launching or moorage facilities, marinas, boat charter services;
- h. Warehouse and marshaling yards for storing goods awaiting transfer to marine vessels or off-loaded from a marine vessel and awaiting immediate pickup by land-based transportation;
- i. Other similar uses, if approved after a public hearing by the Commission, including but not limited to those uses authorized in the Marine Commercial District under HCC §§ 21.28.020 and 21.28.030, provided the Commission finds the use meets the following standards and requirements:
 - 1. The proposed use is compatible with the purpose of Marine Industrial District or provides a necessary service to water-dependent industry,
 - 2. The proposed use is compatible with land use development plans for the Homer Spit and the comprehensive plan,
 - 3. Public facilities and services are adequate to serve the proposed use, and
 - 4. The Port and Harbor Commission, after a public hearing, has made a written recommendation to the Commission concerning the proposed use, including specifically whether conditions (1) through (3) of this subsection are or may, with appropriate conditions, be met by the proposed use;
- j. Mobile food services;
- k. Itinerant merchants, provided all activities shall be limited to uses permitted outright under this zoning district;
- l. Recreational vehicle parks, provided they shall conform to the standards in HCC § 21.54.
- m. As an accessory use, one small wind energy system per lot. (Ord. 09-34(A) §19 (part), 2009; Ord. 08-29, 2008).

21.30.030 Conditional uses and structures. The following uses may be permitted in the Marine Industrial District when authorized by conditional use permit issued in accordance with HCC Chapter 21.71:

- a. Planned unit development, limited to water-dependent or water-related uses and excluding all dwellings;
- b. Boat sales, rentals, service, repair and storage, and boat manufacturing;

- c. Restaurants and drinking establishments;
- d. Extractive enterprises related to other uses permitted in the district;
- e. Campgrounds;
- f. Bulk petroleum storage;
- g. Caretaker's residence as an accessory to a permitted or conditionally permitted use;
- h. Heliports;
- i. Pipelines and railroads;
- j. More than one building containing a permitted principal use on a lot.
- k. Permitted uses that exceed 100 vehicles during peak hour or more than 500 vehicles per day based on the proposed land use and density, calculated utilizing the Trip Generation Manual, Institute of Traffic Engineers, most current edition;
- l. Indoor recreational facilities;
- m. Outdoor recreational facilities. (Ord. 08-29, 2008).

21.30.040 Dimensional requirements. a. Lot Size. The minimum lot size is 6,000 square feet.

b. Setbacks.

1. All buildings shall be set back 20 feet from all dedicated rights-of-way. Alleys are not subject to a 20 foot setback requirement. The setback requirements from any lot line abutting an alley will be determined by the dimensional requirements of subparagraph (2) below.
2. Buildings shall be set back five feet from all other lot boundary lot lines unless adequate firewalls are provided and adequate access to the rear of the building is otherwise provided (e.g., alleyways) as defined by the State Fire Code and enforced by the State Fire Marshal.

c. Building Height.

1. The maximum building height shall be thirty-five feet.

d. No lot shall contain more than 8,000 square feet of building area (all buildings combined), nor shall any lot contain building area in excess of 30 percent of the lot area without an approved conditional use permit.

e. Building Area and Dimensions - Retail and Wholesale.

1. The total square feet floor area of retail and wholesale business uses within a single building shall not exceed 25,000 square feet.
2. In no event may a conditional use permit or variance be granted that would allow a building to exceed the limits of subparagraph (d)(1) and no nonconforming use or structure may be expanded in any manner that would increase its nonconformance with the limits of subparagraph (d)(1). (Ord. 08-29, 2008; Ord. 08-27(S)§1, part, 2008).

21.30.050 Site and access plan. a. A zoning permit for a building or structure within the Marine Industrial District shall not be issued by the City without a level two site plan approved under HCC Chapter 21.73.

b. No zoning permit may be granted without a level two right-of-way access plan approved under HCC Chapter 21.73. (Ord. 08-29, 2008).

21.30.060 Traffic Requirements. A conditional use permit is required for every use that is estimated or expected to generate traffic in excess of the criteria contained in HCC § 21.18.060. (Ord. 08-29, 2008).

21.30.070 Site Development Requirements. a. All site development shall conform to the level two site development standards contained in HCC § 21.50.030.

b. Point source discharges to a waterway shall be in conformance with the Alaska Department of Environmental Conservation regulations. (Ord. 08-29, 2008).

21.30.080 Nuisance Standards. The nuisance standards of HCC § 21.59.010 apply to all development, uses, and structures in this zoning district. (Ord. 08-29, 2008).

21.30.090. Lighting Standards. The level one lighting standards of HCC § 21.59.030 apply to all development, uses, and structures in this zoning district. (Ord. 08-29, 2008).

City of Homer-Lease Application/Assignment Form

Directions:

1. Please type.
2. Please submit this application form to the City Clerk's Office, 491 Pioneer Avenue, Homer, Alaska 99603.
3. Please answer all questions on this form, or put "N/A" in the space if it is non applicable.

| | |
|---|--|
| Applicant Name: | |
| Social Security No.s | |
| Mailing Address: | |
| City, State, ZIP code: | |
| Business Telephone No. | |
| Representative's Name: | |
| Mailing Address: | |
| City, State, ZIP code: | |
| Business Telephone No. | |
| Property Location: | |
| Legal Description: | |
| Type of Business to be placed on property: | |
| Size of Buildings to be placed or leased: | |
| Duration of Lease requested: | |
| Options to re-new: | |
| Special lease requirements: | |
| Number of parking spaces required, per code: | |

**The following materials must be submitted when applying for a lease of
City of Homer real property**

| 1. | Plot Plan | <p>A drawing of the proposed leased property showing:</p> <p><input type="checkbox"/> Size of lot - dimensions and total square footage. – to scale, please.</p> <p><input type="checkbox"/> Placement and size of buildings, storage units, miscellaneous structures planned – to scale, please.</p> <p><input type="checkbox"/> Water and sewer lines – location of septic tanks, if needed.</p> <p><input type="checkbox"/> Parking spaces – numbered on the drawing with a total number indicated – please refer to Homer City Code _____</p> | | | | | | | | | | | | | | | | | | | | |
|---------------------|--------------------------------------|---|--------------|--------------|-------|-------|-------|-------|-------|-------|-------|-------|-------|-------|---------------------|--------------------------------------|-------|-------|-------|-------|-------|-------|
| 2. | Development Plan | <p><input type="checkbox"/> <u>List the time schedule from project initiation to project completion, including major project milestones.</u></p> <table border="0"> <thead> <tr> <th data-bbox="505 709 792 741">Dates</th> <th data-bbox="797 709 1487 741">Tasks</th> </tr> </thead> <tbody> <tr> <td>_____</td> <td>_____</td> </tr> <tr> <td>_____</td> <td>_____</td> </tr> <tr> <td>_____</td> <td>_____</td> </tr> <tr> <td>_____</td> <td>_____</td> </tr> <tr> <td>_____</td> <td>_____</td> </tr> </tbody> </table> <p>For each building, indicate:</p> <table border="0"> <thead> <tr> <th data-bbox="505 1037 971 1068">Building Use</th> <th data-bbox="980 1037 1511 1068">Dimensions and square footage</th> </tr> </thead> <tbody> <tr> <td>_____</td> <td>_____</td> </tr> <tr> <td>_____</td> <td>_____</td> </tr> <tr> <td>_____</td> <td>_____</td> </tr> </tbody> </table> | Dates | Tasks | _____ | _____ | _____ | _____ | _____ | _____ | _____ | _____ | _____ | _____ | Building Use | Dimensions and square footage | _____ | _____ | _____ | _____ | _____ | _____ |
| Dates | Tasks | | | | | | | | | | | | | | | | | | | | | |
| _____ | _____ | | | | | | | | | | | | | | | | | | | | | |
| _____ | _____ | | | | | | | | | | | | | | | | | | | | | |
| _____ | _____ | | | | | | | | | | | | | | | | | | | | | |
| _____ | _____ | | | | | | | | | | | | | | | | | | | | | |
| _____ | _____ | | | | | | | | | | | | | | | | | | | | | |
| Building Use | Dimensions and square footage | | | | | | | | | | | | | | | | | | | | | |
| _____ | _____ | | | | | | | | | | | | | | | | | | | | | |
| _____ | _____ | | | | | | | | | | | | | | | | | | | | | |
| _____ | _____ | | | | | | | | | | | | | | | | | | | | | |
| 3. | Insurance | <p><input type="checkbox"/> Attach a statement of proof of insurability of lessee for a minimum liability insurance for combined single limits of \$1,000,000 showing the City of Homer as co-insured. Additional insurance limits may be required due to the nature of the business, lease or exposure. Environmental insurance may be required. If subleases are involved, include appropriate certificates of insurance.</p> | | | | | | | | | | | | | | | | | | | | |
| 4. | Subleases | <p><input type="checkbox"/> Please indicate and provide a detailed explanation of any plans that you may have for subleasing the property. The City of Homer will generally require payment of 25% of proceeds paid Lessee by subtenants. Refer to chapter 13 of the Property Management Policy and Procedures manual.</p> | | | | | | | | | | | | | | | | | | | | |
| 5. | Health Requirements | <p><input type="checkbox"/> Attach a statement documenting that the plans for the proposed waste disposal system, and for any other necessary health requirements, have been submitted to the State Department of Environmental Conservation for approval. Granting of this lease shall be contingent upon the lessee obtaining all necessary approvals from the State DEC.</p> | | | | | | | | | | | | | | | | | | | | |
| 6. | Agency Approval | <p><input type="checkbox"/> Attach statement(s) of proof that your plans have been inspected and approved by any agency which may have jurisdiction of the project; i.e. Fire Marshall, Army Corps of Engineers, EPA, etc. The granting of this lease shall be contingent upon lessee obtaining approval, necessary permits, and/or inspection statements from all appropriate State and/or Federal agencies.</p> | | | | | | | | | | | | | | | | | | | | |

| | | |
|----|-----------------------|--|
| 7. | Fees | <p><u>All applicable fees must be submitted prior to the preparation and/or execution of a lease.</u></p> <p><input type="checkbox"/> Application fee - \$30.00. Covers costs associated with processing the application.</p> <p><input type="checkbox"/> Lease fee - \$300.00. Covers the costs of preparing and processing the actual lease.</p> <p><input type="checkbox"/> Assignment fee - \$250.00. Covers the costs of preparing and processing the lease transfer.</p> |
| 8. | Financial Data | <p><u>Please indicate lessee's type of business entity:</u></p> <p><input type="checkbox"/> Sole or individual proprietorship.</p> <p><input type="checkbox"/> Partnership.</p> <p><input type="checkbox"/> Corporation.</p> <p><input type="checkbox"/> Other – Please explain: _____</p> <p>_____</p> <p>_____</p> <p><input type="checkbox"/> Financial Statement – Please attach a financial statement showing the ability of the lessee to meet the required financial obligations.</p> <p><input type="checkbox"/> Surety Information – Has any surety or bonding company ever been required to perform upon your default or the default of any of the principals in your organization holding more than a 10% interest <input type="checkbox"/> No <input type="checkbox"/> Yes. If yes, please attach a statement naming the surety or bonding company, date and amount of bond, and the circumstances surrounding the default or performance.</p> <p><input type="checkbox"/> Bankruptcy information - Have you or any of the principals of your organization holding more than a 10% interest ever been declared bankrupt or are presently a debtor in a bankruptcy action? <input type="checkbox"/> No <input type="checkbox"/> Yes. If yes, please attach a statement indicating state, date, Court having jurisdiction, case number and to amount of assets and debt.</p> <p><input type="checkbox"/> Pending Litigation – Are you or any of the principals of your organization holding more than a 10% interest presently a party to any pending litigation? <input type="checkbox"/> No <input type="checkbox"/> Yes. If yes, please attach detailed information as to each claim, cause of action, lien, judgment including dates and case numbers.</p> |
| 9. | Partnership Statement | <p><input type="checkbox"/> <u>If the applicant is a partnership, please provide the following:</u></p> <p>Date of organization: _____</p> <p>Type: <input type="checkbox"/> General Partnership <input type="checkbox"/> Limited Partnership</p> <p>Statement of Partnership Recorded? <input type="checkbox"/> Yes <input type="checkbox"/> No Where _____ When _____</p> <p>Has partnership done business in Alaska? <input type="checkbox"/> Yes <input type="checkbox"/> No Where _____ When _____</p> <p>Name, address, and partnership share. If partner is a corporation, please complete corporation statement.</p> <p>Limited/ <u>General</u> <u>Name</u> <u>Address</u> <u>Share %</u></p> <p>_____</p> |

| | | |
|-------------------|------------------------------------|--|
| <p>11.</p> | <p>Applicant References</p> | <p>Please list four persons or firms with whom the Applicant or its owners have conducted business transactions with during the past three years. Two references named shall have knowledge of your financial management history, of which at least one must be your principal financial institution. Two of the references must have knowledge of your business expertise.</p> <p>_____</p> <p>Name: _____ Firm: _____ Title: _____ Address: _____ Telephone: _____ Nature of business association with Applicant: _____</p> <p>_____</p> <p>Name: _____ Firm: _____ Title: _____ Address: _____ Telephone: _____ Nature of business association with Applicant: _____</p> <p>_____</p> <p>Name: _____ Firm: _____ Title: _____ Address: _____ Telephone: _____ Nature of business association with Applicant: _____</p> <p>_____</p> <p>Name: _____ Firm: _____ Title: _____ Address: _____ Telephone: _____ Nature of business association with Applicant: _____</p> <p>_____</p> |
|-------------------|------------------------------------|--|

I hereby certify that the above information is true and correct to the best of my knowledge.
Signature: _____ **Date:** _____

GROUND LEASE AND SECURITY AGREEMENT

BETWEEN

CITY OF HOMER, ALASKA

AND

Dated _____, 2011

GROUND LEASE AND SECURITY AGREEMENT

GROUND LEASE AND SECURITY AGREEMENT (“Lease”) dated as of _____, 201__, between the CITY OF HOMER, an Alaska municipal corporation (“Landlord”), whose address is 491 East Pioneer Avenue, Homer, Alaska 99603, and _____ a _____ [state of organization] _____ [type of entity] (“Tenant”), whose address is _____.

OPTIONAL PARAGRAPH, APPLICABLE WHEN TENANT IS NOT A NATURAL PERSON

Attached as **Exhibit A** is a schedule naming each owner of Tenant and describing the percentage of ownership of each. Also attached to **Exhibit A** are a certificate of good standing issued by the state under whose laws Tenant is organized, and, if Tenant is a foreign entity, a certificate of authority issued by the State of Alaska. Attached as **Exhibit B** is a true and correct copy of a resolution of Tenant authorizing Tenant to enter into this Lease and authorizing the undersigned individual(s) or officer(s) to execute the Lease on behalf of Tenant.

RECITALS

WHEREAS, Landlord owns certain properties having a strategic location near the waterfront and marine-related public infrastructure; and

WHEREAS, it is the policy of Landlord to retain ownership of these properties, and to make them available for leasing, in order to encourage growth in targeted economic sectors, to insure that Landlord receives the maximum benefit from a large investment in public infrastructure, and to provide land for businesses that require close proximity to the waterfront or infrastructure to operate efficiently and profitably; and

WHEREAS, Landlord has accepted Tenant’s proposal to lease and develop the property leased herein, because Tenant’s proposed use of the property should further Landlord’s goals for the development of Landlord’s properties, and Tenant’s proposal to lease and develop the property is a material inducement to Landlord leasing the property to Tenant; and

WHEREAS, Tenant has made its own determination that its proposed development of the property will be economically feasible, and that the term for which it is leasing the property will be sufficient to amortize Tenant’s investment in developing the leased property under Tenant’s proposal.

NOW, THEREFORE, in consideration of the matters recited above, and the mutual covenants herein, the parties agree as follows:

ARTICLE 1. DEFINITIONS AND ATTACHMENTS

1.01 Definitions. As used herein, the term:

(a) “Annual Rent Adjustment” and “Annual Rent Adjustment Date” are defined in Section 4.01(b).

(b) “Base Rent” is defined in Section 4.01.

(c) "Complete" and "Completion" mean, with regard to an improvement, that construction of the improvement is finished and the improvement is fully operational and ready for occupancy or use for its intended purpose, including without limitation the issuance of any applicable certificate of occupancy and other applicable permits, licenses, certificates or inspection reports necessary to the improvement's legally authorized use.

(d) "Council" means the City Council of the City of Homer, Alaska.

(e) "Default Rate" means an annual rate of interest equal to the lesser of (i) the maximum rate of interest for which Tenant may lawfully contract in Alaska, or (ii) ten and one-half percent (10.5%).

(f) "Environmental Laws" means all local, state, and federal laws, ordinances, regulations, and orders related to environmental protection; or the use, storage, generation, production, treatment, emission, discharge, remediation, removal, disposal, or transport of any Hazardous Substance.

(g) "Excusable Delay" means delay due to strikes, acts of God, inability to obtain labor or materials, orders of any governmental authority having jurisdiction, removal of Hazardous Materials discovered at any time after the commencement of the Term, enemy action, civil commotion, fire, unusual inclement weather, unavoidable casualty or similar causes beyond the reasonable control of Tenant.

(h) "Extended Term" is defined in Section 3.02.

(i) "Five Year Rent Adjustment Date" is defined in Section 4.02(a).

(j) "Hazardous Substance" means any substance or material defined or designated as hazardous or toxic waste; hazardous or toxic material; hazardous, toxic, or radioactive substance; or other similar term by any federal, state, or local statute, regulation, or ordinance or common law presently in effect or that may be promulgated in the future as such statutes, regulations, and ordinances may be amended from time to time.

(k) "Landlord" means the City of Homer, Alaska.

(l) "Lease Policy" means the City of Homer Property Management Policy and Procedures, as adopted and amended from time to time by Council resolution.

(m) "Leasehold Mortgage" is defined in Section 13.01.

(n) "Property" is defined in Section 2.01.

(o) "Qualified Mortgagee" is defined in Section 13.03.

(p) "Required Improvements" is defined in Section 6.02.

(q) "Tenant" means _____.

(r) "Term" is defined in Section 3.01.

1.02 Attachments. The following documents are attached hereto, and such documents, as well as all drawings and documents prepared pursuant thereto, shall be deemed to be a part hereof:

Exhibit "A" Schedule of Organization, Owners, Percentage of Ownership

Exhibit "B" Conformed Copy of Resolution Authorizing Lease and Authorizing Signers to Sign Lease Agreement on Behalf of Tenant

Exhibit "C" Legal Description of Property

Exhibit "D" Tenant's Lease Proposal

Exhibit "E" Site Plan

Exhibit "F" Required Improvements Floor Plan

Exhibit "G" Certificates of Insurance

Exhibit "H" Permission to Obtain Insurance Policies

ARTICLE 2. THE PROPERTY

2.01 Lease of Property. Subject to the terms and conditions of this Lease, Landlord leases to Tenant and Tenant leases from Landlord the following described property ("Property"):

[must insert legal description], Homer Recording District, State of Alaska, as depicted on **Exhibit C**, containing _____ square feet, more or less, also known as Kenai Peninsula Borough Tax Parcel No. _____;

subject, however, to reservations, restrictions, easements and encumbrances of record, and to encroachments that may be revealed by an inspection of the Property.

2.02 Quiet Enjoyment. Landlord covenants that Tenant, upon paying the rent and other charges and performing its other obligations under this Lease shall have quiet enjoyment of the Property during the Term without hindrance or interference by Landlord or by any person claiming an interest in the Property through Landlord.

2.03 Property Accepted "As Is." Tenant has inspected the Property, has made its own determination as to the suitability of the Property for Tenant's intended use, and accepts the Property "AS IS." Landlord, its agents and employees make no warranties, expressed or implied, concerning the condition of the Property, including without limitation the habitability or fitness of the Property for any particular purpose, including those uses authorized by this Lease, or subsurface and soil conditions, including the presence of any Hazardous Substance.

OPTIONAL PARAGRAPH 2.03. __ APPLICABLE IF TENANT OBTAINS ENVIRONMENTAL ASSESSMENT.

2.03 Property Accepted "As Is;" Exception for Hazardous Substances.

(a) Tenant has inspected the Property, has made its own determination as to the suitability of the Property for Tenant's intended use, and accepts the Property "AS IS." Except as provided in subsection (b), Landlord, its agents and employees make no warranties, expressed or implied, concerning the condition of the Property, including without limitation the habitability or fitness of the Property for any particular purpose, including those uses authorized by this Lease, or subsurface and soil conditions.

(b) Tenant shall obtain, at its own expense, a phase I environmental assessment of the Property as of the earlier of (i) the commencement of the Term, and (ii) Tenant's initial occupancy of the Property. If Landlord reasonably determines that the phase I environmental assessment is acceptable, Landlord will warrant that the condition of the Property as of the applicable date with regard to the presence of any Hazardous Substance is consistent with the results of the phase I environmental assessment.

2.04 No Subsurface Rights. This Lease confers no mineral rights or rights with regard to the subsurface of the Property below the level necessary for the uses of the Property permitted in this Lease.

ARTICLE 3. TERM

3.01 Lease Term. The term of this Lease is _____ years, commencing on _____ 201__, and ending on _____, 201__ ("Term").

3.02. Options to Extend Lease Term.

(a) Tenant has the option to extend the Term for _____ additional, consecutive _____ year periods (each an "Extended Term"), provided that:

(1) Tenant gives Landlord written notice of its exercise of the option not more than one year and not less than 120 days before the last day of the Term or current Extended Term, as the case may be;

(2) At the time Tenant exercises the option, and at all times thereafter until the Extended Term commences, Tenant is not materially in default of any term or condition of this Lease and has not made an assignment or subletting of this Lease or any interest in the Property except as permitted under this Lease; and

3) Tenant may exercise no more than one option to extend the Term during the Term or any Extended Term.

(b) Tenant's failure to exercise an option to extend the Term in strict compliance with all the requirements in Section 3.02(a) renders that option and all options as to subsequent Extended Terms null and void.

3.03 Lease Renewal.

(a) Tenant represents and warrants that it has determined that the duration of the Term, plus any available Extended Terms, will be sufficient for Tenant to amortize any investment that it

makes in connection with this Lease, including without limitation any investment in leasehold improvements. Tenant acknowledges that it has no right of any kind to continue using or occupying the Property after the expiration or earlier termination of the Term or the final Extended Term, including without limitation any option to renew this Lease, or any option to extend the Term other than as provided in Section 3.02.

(b) Not less than 12 months before the expiration of the Term or the final Extended Term, Tenant may apply to Landlord for a renewal of this Lease in the manner that a person then would apply for a new lease of the Property. In response to a timely application, the Council will determine whether to renew this Lease, and the term of any renewal, in its sole discretion. The Council is under no obligation to renew this Lease, or to renew this Lease for the term that Tenant requests. If the Council does not grant a timely application to renew this Lease, Tenant shall prepare to surrender possession of the Property as required by Section 3.04, and dispose of improvements on the Property as required by Section 6.08.

3.04 Surrender of Possession. Upon the expiration or earlier termination of the Term or the final Extended Term, Tenant shall promptly and peaceably surrender the Property, clean, free of debris, and in as good order and condition as at the commencement of the Term, ordinary wear and tear excepted, and shall remove from the Property all personal property that was not present on the Property at the commencement of the Term. If Tenant fails to surrender the Property in the required condition, Landlord may restore the Property to such condition and Tenant shall pay the cost thereof, plus interest at the Default Rate, on demand. Section 6.08 governs the disposition of improvements on the Property at the expiration or earlier termination of the Term or final Extended Term.

3.05 Holding Over. Tenant's continuing in possession of the Property after the expiration or earlier termination of the Term or final Extended Term will not renew or extend this Lease. In the absence of any agreement renewing or extending this Lease, Tenant's continued possession of the Property after the end of the Term will be a tenancy from month to month, terminable upon 30 days written notice by either party at any time, at a monthly rental equal to 150% of the monthly Base Rent in effect at the end of the Term, subject to all other terms of this Lease. For good cause, Landlord may waive all or part of the increase in Base Rent during the holdover period.

ARTICLE 4. RENT, TAXES, ASSESSMENTS AND UTILITIES

4.01 Base Rent. Tenant shall pay to Landlord an initial annual rent of \$_____, ("Base Rent"). Base Rent is payable monthly in advance in installments of \$_____, plus tax, on _____, 201_, and on the _____ day of each month thereafter, at the office of the City of Homer, 491 East Pioneer Avenue, Homer, Alaska 99603-7645, or at such other place as Landlord may designate in writing. All Base Rent shall be paid without prior demand or notice and without deduction or offset. Base Rent that is not paid on or before the due date will bear interest at the Default Rate. Base Rent is subject to adjustment as provided in Section 4.02.

4.02 Rent Adjustments.

(a) **Five-Year Appraised Rent Adjustments.** Commencing January 1, _____, and in every fifth year thereafter, Landlord will obtain an appraisal by a qualified real estate appraiser of the fair rental value of the Property as if privately owned in fee simple, excluding the value of improvements (other than utilities) made by tenants. The appraisal may be performed as part of an

appraisal of other properties of Landlord that are comparable in location and value. The Base Rent will be adjusted effective _____ of the year of each appraisal (each such date is a "Five Year Rent Adjustment Date") to an amount equal to the greater of (i) the area of the Property in square feet, multiplied by the fair rental value per square foot determined by the appraisal, and (ii) the adjusted Base Rent in effect immediately before the Five Year Rent Adjustment Date. The rent adjusted on a Five Year Rent Adjustment Date thereafter shall be the Base Rent.

(b) **Annual Rent Adjustments.** In addition to the rent adjustments under Section 4.02(a), the Base Rent also shall be adjusted annually (the "Annual Rent Adjustment") effective _____, and on each _____ thereafter, excluding each Five Year Rent Adjustment Date (each such date being an "Annual Rent Adjustment Date"), by the increase or decrease, if any, for the previous year in the cost of living as stated in the Consumer Price Index, All Urban Consumers, Anchorage, Alaska Area, All Items 2000 – present = 100 ("CPI-U"), as published by the United States Department of Labor, Bureau of Labor Statistics most recently before the Annual Rent Adjustment Date. If the CPI-U is revised or ceases to be published, Landlord instead shall use such revised or other index, with whatever adjustment in its application is necessary, to most nearly approximate in Landlord's judgment the CPI-U for the relevant period.

4.03 Taxes, Assessments and Other Governmental Charges. Tenant shall pay prior to delinquency all taxes, installments of assessments that are payable in installments and other governmental charges lawfully levied or assessed upon or with respect to the Property, improvements on the Property and personal property that is situated on the Property; provided that Tenant may contest in good faith any such tax, assessment or other governmental charge without subjecting the Property to lien or forfeiture. If an assessment on the Property that is not payable in installments becomes due during the Term or an Extended Term, Tenant shall be obligated to pay the fraction of the assessment that is determined by dividing the number of years remaining in the Term or Extended Term by 10. If this Lease subsequently is extended or renewed, the part of the assessment that Tenant shall pay shall be determined by adding the extended or renewal term to the number of years remaining in the Term when the assessment became due. If the Term commences or expires during a tax year, the taxes or assessments payable for that year will be prorated between Landlord and Tenant. Tenant shall exhibit to Landlord, on demand, receipts evidencing payment of all such taxes, assessments and other governmental charges.

4.04 Utility Charges. Tenant shall pay all charges for utility and other services provided to or used on the Property, including without limitation gas, heating oil, electric, water, sewer, heat, snow removal and refuse removal. Tenant shall be solely responsible for the cost of utility connections.

4.05 Tenant to Pay for City Services. Tenant shall pay for all services provided by the City of Homer that are related to the use or operation of the Property, improvements thereon and Tenant's activities thereon. Without limiting the generality of the preceding sentence, Tenant shall pay for wharfage, crane use, ice, and other Port and Harbor services at the rates established by the City of Homer from time to time. Tenant shall provide the City of Homer with the information necessary to determine wharfage, crane use, ice and other Port and Harbor service charges, keep written records of such information for not less than two years after such charges are due, and, upon request, make such records available to the City of Homer for inspection and audit.

4.06 Additional Rent and Landlord's Right to Cure Tenant's Default. All costs or expenses that Tenant is required to pay under this Lease at Landlord's election will be treated as additional rent, and Landlord may exercise all rights and remedies provided in this Lease in the event of nonpayment. If Tenant defaults in making any payment required of Tenant or defaults in performing any term, covenant or condition of this Lease that involves the expenditure of money by Tenant, Landlord may, but is not obligated to, make such payment or expenditure on behalf of Tenant, and any and all sums so expended by Landlord, with interest thereon at the Default Rate from the date of expenditure until repaid, will be additional rent and shall be repaid by Tenant to Landlord on demand, provided, however, that such payment or expenditure by Landlord will not waive Tenant's default, or affect any of Landlord's remedies for such default.

4.07 Security Deposit. Upon execution of this Lease, Tenant shall deposit with Landlord an amount equal to 10% of the annual Base Rent as security for Tenant's performance of its obligations under this Lease. Landlord will hold the security deposit, and may commingle it with other funds of Landlord. If Tenant defaults in performing any obligation under this Lease, including without limitation the payment of rent, Landlord may apply all or any portion of the security deposit to the payment of any sum in default or any damages suffered by Landlord as result of the default, or any sum that Landlord may be required to incur by reason of the default. Upon demand, Tenant shall deposit with Landlord the amount so applied so that Landlord will have the full deposit on hand at all times during the Term or Renewal Term. If Tenant has fully complied with all of its obligations under this Lease through the first five years of the Term, Landlord will remit to Tenant any balance of the security deposit, without interest, within 30 days after the expiration of the first five years of the Term.

OPTIONAL PARAGRAPH 4.08, APPLICABLE TO FISH PROCESSORS WITH ACCESS TO OUTFALL LINE

4.08 Outfall Line Connection Agreement. Tenant shall connect to the City of Homer fish processor outfall line. On or before the commencement of the Term of this Lease, Tenant shall enter into a Fish Processor Outfall Line Connection Agreement with Landlord, and thereafter at its own expense install and maintain a fish grinder as required by the Fish Processor Outfall Line Connection Agreement. Tenant shall comply with the terms of the Fish Processor Outfall Line Connection Agreement until the earlier to occur of (i) the expiration or earlier termination of the Term and any Extended Term, and (ii) the date the City of Homer ceases to maintain the outfall line.

ARTICLE 5. SECURITY INTEREST

To secure the performance of Tenant's obligations under this Lease, including without limitation the obligations to pay rent and other sums to be paid by Tenant, Tenant grants to Landlord a security interest in the following collateral: ("Collateral"): (1) all security deposits or other monies owing from Landlord to Tenant (as collateral in the possession of the secured party); (2) all insurance proceeds from any policy insuring the Property or improvements thereon against environmental contamination or pollution; (3) all compensation payable to Tenant as a result of eminent domain proceedings or a transfer in lieu thereof; and (4) all rents from Tenant's subletting of all or a part of the Property. Said lien and security interest will be in addition to Landlord's liens provided by law.

This Lease constitutes a security agreement under the Uniform Commercial Code as

enacted in Alaska ("UCC"), and Landlord will have all rights and remedies of a secured party under the UCC regarding the Collateral. Tenant shall execute, such financing statements and other instruments as Landlord may now or hereafter reasonably request to evidence the security interest granted by Tenant.

ARTICLE 6. USE AND IMPROVEMENT OF PROPERTY

6.01 Use of Property. Tenant’s undertaking to use and improve the Property as described in Tenant’s proposal to Landlord is a material inducement to Landlord leasing the Property to Tenant. Tenant shall improve and use the Property in the manner described in Tenant’s proposal. Tenant’s proposed use of the Property is described in **Exhibit D**. Tenant shall not use or improve the Property for any purpose other than as described in Tenant’s proposal without Landlord’s written consent, which consent Landlord may withhold in its sole discretion.

6.02 Required Improvements. Tenant shall, at Tenant’s sole expense, construct, and at all times during the Term and any Renewal Term keep and maintain as the minimum development on the Property the following improvements (“Required Improvements”):

The Required Improvements also are depicted in the site plan and floor plans in **Exhibit E** and **Exhibit F**, respectively. Tenant shall commence construction of the Required Improvements within one year after the date of commencement of the Term, prosecute the construction of the Required Improvements with diligence, and Complete construction within one additional year.

6.03 Construction Prerequisites. Tenant may not commence any construction on the Property, including without limitation construction of the Required Improvements, without first satisfying the following conditions:

_____(a) Not less than 30 days before commencing construction, Tenant shall submit to Landlord preliminary plans and specifications, and an application for a City of Homer zoning permit, for the construction, showing the layout of proposed buildings and other improvements, ingress and egress, dimensions and locations of utilities, drainage plans, and any other information required for the zoning permit or other required permits. The preliminary plans and specifications are subject to Landlord’s approval, which will not be unreasonably withheld. Landlord shall communicate approval or disapproval in the manner provided for notices, accompanying any disapproval with a statement of the grounds therefor. Tenant shall be responsible for complying with all laws governing the construction, notwithstanding Landlord’s approval of preliminary plans and specifications under this paragraph.

(b) Not less than five days before commencing construction, Tenant shall deliver to Landlord one complete set of final working plans and specifications as approved by the governmental agencies whose approval is required for Tenant to commence construction. The final working plans and specifications shall conform substantially to the preliminary plans and specifications previously approved by Landlord, subject to changes made to comply with

suggestions, requests or requirements of a governmental agency or official in connection with the application for permit or approval.

(c) Not less than five days before commencing construction, Tenant shall give Landlord written notice of its intent to commence construction, and furnish to Landlord the following:

(1) Proof that all applicable federal, state and local permits required for the construction have been obtained.

(2) For construction, alteration or restoration of Required Improvements, a current certificate of insurance with the coverages specified in Section 9.04(c).

6.04 Extensions of Time for Completion of Required Improvements. Landlord shall grant an extension of the time to Complete the Required Improvements for a period of time equal to the duration of an Excusable Delay, upon Tenant's written request describing the nature of the Excusable Delay, provided Tenant has commenced construction in a timely manner and is proceeding diligently to Complete construction.

6.05 Additional and Replacement Improvements.

(a) Construction of improvements that are not consistent with terms of this Lease is prohibited unless the improvements are authorized by an amendment to this Lease approved by the Council.

(b) Subject to Section 6.05(a), upon satisfying the conditions in section 6.03, Tenant at any time may, but is not obligated to, construct new improvements on the Property and demolish, remove, replace, alter, relocate, reconstruct or add to existing improvements; provided that Tenant is not then in default under this Lease and provided further that Tenant continuously maintains on the Property the Required Improvements, or their equivalent of equal or greater value. Once any work is begun, Tenant shall with reasonable diligence prosecute to Completion all construction of improvements, additions, alterations, or other work. All salvage resulting from such work will belong to Tenant, who is responsible for its removal and lawful disposal.

6.06 As-Built Survey. Within 30 days after Completion of construction of any improvements on the Property involving construction, alteration, addition, removal or demolition of the foundation, structure, utility services, ingress and egress, or any major changes of all or any part of any structure or improvement on the Property, Tenant shall provide Landlord with three copies of an as-built survey of the Property prepared by a registered professional surveyor, showing the location of all improvements on the Property, including underground utilities, pipelines and pre-existing improvements. Tenant shall accompany the as-built survey with a description of all changes from the approved plans or specifications made during the course of the work.

6.07 Ownership of Improvements. Any and all buildings, fixtures and improvements of any nature whatsoever constructed or maintained on the Property by Tenant will be and remain the property of Tenant at all times during the Term and any Extended Terms and may be removed or replaced by Tenant, subject, however, to (i) Tenant's obligations concerning the Required Improvements in Section 6.02; and (ii) the designation of improvements in **Exhibit D** for transfer to Landlord and retention on the Property at the expiration of the Term or Extended Term as

provided in Section 6.08(a).

6.08 Disposition of Improvements at End of Term.

(a) At the expiration of the Term or Extended Term Tenant shall leave in place on the Property all improvements designated in **Exhibit D** for transfer to Landlord and retention on the Property at the expiration of the Term or Extended Term. Tenant shall leave such improvements intact with all components, including without limitation doors, windows, and plumbing, electrical and mechanical fixtures and systems, in good condition and ready for use or occupancy. Tenant shall execute, acknowledge and deliver to Landlord a proper instrument in writing, releasing and quitclaiming to Landlord all of Tenant's interest in such improvements. Except for improvements that Tenant is required to leave on the Property, Tenant shall remove any improvements constructed by Tenant or other occupants of the Property under this Lease before the expiration of the Term or Extended Term.

(b) Tenant shall notify Landlord before commencing the removal of an improvement as required under Section 6.08(a), and coordinate the removal work with Landlord. Once Tenant commences the removal work, Tenant shall prosecute the removal with reasonable diligence to Completion and shall repair all damages to the Property caused by such removal no later than the expiration of the Term or Extended Term. All salvage resulting from such work will belong to Tenant, who is responsible for its removal and lawful disposal.

(c) If Tenant fails to remove any improvements from the Property that Tenant is required to remove under Section 6.08(a), Tenant shall pay Landlord the costs that it incurs in removing and disposing of the improvements and repairing damages to the Property caused by such removal.

(d) If Landlord terminates this Lease because of a default by Tenant, all improvements on the Property become the property of Landlord, which may use or dispose of them in its sole discretion. If Landlord elects to remove any improvements, Tenant shall pay Landlord the costs that it incurs in removing and disposing of the improvements and repairing damages to the Property caused by such removal.

ARTICLE 7. CARE AND USE OF THE PROPERTY

7.01 Maintenance of the Property. Tenant at its own cost and expense shall keep the Property and all buildings and improvements that at any time may be situated thereon in a clean, safe and orderly condition, and in good repair at all times during the Term.

7.02 Repair of Improvements.

(a) Except as provided in Section 7.02(b), in the event any buildings or improvements situated on the Property by Tenant are damaged or destroyed by fire, earthquake, tsunami, or other casualty, Tenant shall at Tenant's expense restore the same to good and tenable condition or shall remove the same as soon as is reasonably possible, but in no event may the period of restoration exceed 18 months nor may the period of removal exceed 45 days.

(b) Unless Tenant is excused from the obligation under this paragraph, if the Required Improvements or any part thereof are damaged or destroyed by fire, earthquake, tsunami, or other casualty, rendering the Required Improvements totally or partially inaccessible or unusable,

Tenant shall at Tenant's expense restore the Required Improvements to substantially the same condition as they were in immediately before such damage. Tenant shall not be required to restore the Required Improvements under the following circumstances:

(1) If the cost of repairing or restoring the Required Improvements, net of any available insurance proceeds not reduced by applicable deductibles and coinsurance, exceeds 10% of the replacement cost of the Required Improvements, Tenant may terminate this Lease by giving notice to Landlord of Tenant's election to terminate within 15 days after determining the restoration cost and replacement cost, and this Lease shall terminate as of the date of such notice.

(2) If the repair or restoration of the Required Improvements would be contrary to law, either party may terminate this Lease immediately by giving notice to the other party.

(3) If any damage or casualty to the Required Improvements occurs within three years before the end of the Term or any Renewal Term, Tenant may, in lieu of restoring or replacing the Required Improvements, terminate this Lease by giving written notice of termination to Landlord within 120 days after such damage or casualty.

Nothing in this paragraph relieves Tenant of the obligation to surrender the Property upon the expiration or earlier termination of the Term in the condition required by Section 3.03.

(c) Under no circumstance shall Landlord be under any obligation to use or advance any of its own funds to restore any Required Improvements.

7.03 Nuisances Prohibited. Tenant at all times shall keep the Property in a clean, orderly and sanitary condition and free of insects, rodents, vermin and other pests; junk, abandoned or discarded property, including without limitation vehicles, equipment, machinery or fixtures; and litter, rubbish or trash. Tenant shall not use the Property in any manner that will constitute waste or a nuisance. Landlord, at Tenant's expense and without any liability to Tenant, may remove or abate any such junk, abandoned or discarded property, litter, rubbish or trash, or nuisance on the Property after 15 days written notice to Tenant, or after four hours notice to Tenant in writing, by telephone, facsimile or in person if Landlord makes a written finding that such removal or abatement is required to prevent imminent harm to public health, safety or welfare. Tenant shall pay Landlord all the costs of such removal, plus interest at the Default Rate, as additional rent under this Lease. This section does not limit or waive any other remedy available to the City of Homer to abate any nuisance or for the violation of the Homer City Code.

7.04 Compliance with Laws. Tenant's improvement and use of the Property shall comply with all governmental statutes, ordinances, rules and regulations, including without limitation the City of Homer Zoning Code and all applicable building codes, now or hereafter in effect.

7.05 Liens. Except as provided in Article 13, Tenant may not permit any lien, including without limitation a mechanic's or materialman's lien, to be recorded against the Property. If any such lien is recorded against the Property, Tenant shall cause the same to be removed; provided that Tenant may in good faith and at Tenant's own expense contest the validity of any such lien without subjecting the Property to foreclosure, and in the case of a mechanic's or materialman's lien, if Tenant has furnished the bond required in A.S. 34.35.072 (or any comparable statute hereafter enacted providing for a bond freeing the Property from the effect of such a lien claim). Tenant shall indemnify and save Landlord harmless from all liability for damages occasioned by

any such lien, together with all costs and expenses (including attorneys' fees) incurred by Landlord in negotiating, settling, defending, or otherwise protecting against such lien and shall, in the event of a judgment of foreclosure of the lien, cause the same to be discharged and removed prior to any attempt at execution of such judgment.

7.06 Radio Interference. Upon Landlord's request, Tenant shall discontinue the use on the Property of any source of electromagnetic radiation that interferes with any government operated transmitter, receiver, or navigation aid until the cause of the interference is eliminated.

7.07 Signs. Tenant may erect signs on the Property that comply with state and local sign laws and ordinances. City Planning Department approval is required prior to the erection of any sign on the Property.

7.08 Garbage Disposal. Tenant shall keep any garbage, trash, rubbish or other refuse in industry standard containers until removed, and cause all garbage, trash, rubbish or other refuse on the Property to be collected and transported to a Kenai Peninsula Borough solid waste facility or transfer station at least once a week. Tenant may not place garbage, trash, rubbish or other refuse from the Property in Landlord's Homer Spit garbage disposal facilities.

7.09 Access Rights of Landlord. Landlord's agents and employees shall have the right, but not the obligation, to enter the Property at all reasonable times to inspect the use and condition of the Property; to serve, post or keep posted any notices required or allowed under the provisions of this Lease, including notices of non-responsibility for liens; and to do any act or thing necessary for the safety or preservation of the Property.

OPTIONAL PARAGRAPH 7. __ APPLICABLE FOR USE OF FISH DOCK

7. Fish Dock Use Permit. Before using the City of Homer Fish Dock, Tenant shall obtain a City of Homer Fish Dock Use Permit. Tenant shall continue to have a current Fish Dock Use Permit in force until the earlier to occur of (i) the expiration or earlier termination of the Term and any Extended Term, and (ii) the date Tenant ceases to use the Fish Dock.

OPTIONAL PARAGRAPH 7. __ APPLICABLE FOR USE OF OTHER DOCKS

7. Terminal Use Permit. Before using City of Homer Docks other than the Fish Dock, Tenant shall obtain a City of Homer Terminal Use Permit. Tenant shall continue to have a current Terminal Use Permit in force until the earlier to occur of (i) the expiration or earlier termination of the Term and any Extended Term, and (ii) the date Tenant ceases to use City of Homer Docks other than the Fish Dock.

8.01 Consent Required for Assignment or Sublease. Tenant shall not assign or sublease its interest in this Lease or in the Property without first obtaining the written consent of the Council, which will not be withheld unreasonably. Any assignment or sublease without the consent of the Council will be voidable and, at Landlord's election, will constitute a default. Tenant shall request consent of the Council in writing at least 30 days prior to the effective date of the proposed assignment or sublease, accompanied by a copy of the proposed assignment or sublease. Tenant shall be assessed additional rent, equal to 10% of the current Base Rent for the

subleased area, but not upon a sublease of space within a building or other structure on the Property. No consent to any assignment or sublease waives Tenant's obligation to obtain Landlord's consent to any subsequent assignment or sublease. An assignment of this Lease shall require the assignee to assume the Tenant's obligations hereunder, and shall not release Tenant from liability hereunder unless Landlord specifically so provides in writing.

8.02. Events that Constitute an Assignment. If Tenant is a partnership or limited liability company, a withdrawal or change, voluntary, involuntary or by operation of law, of one or more partners or members owning 25% or more of the entity, or the dissolution of the entity, will be deemed an assignment subject to Section 8.01. If Tenant is a corporation, any dissolution, merger, consolidation or other reorganization of Tenant, or the sale or other transfer of a controlling percentage of the capital stock of Tenant, or the sale of 25% of the value of the assets of Tenant, will be deemed an assignment subject to Section 8.01; provided that if Tenant is a corporation the stock of which is traded through an exchange or over the counter, a sale or other transfer of a controlling percentage of the capital stock of Tenant will not constitute an assignment subject to Section 8.01. The phrase "controlling percentage" means the ownership of, and the right to vote, stock possessing at least 25% of the total combined voting power of all classes of Tenant's capital stock issued, outstanding and entitled to vote for the election of directors.

8.03. Costs of Landlord's Consent to be Borne by Tenant. As a condition to Landlord's consent to any assignment or sublease under section 8.01, Tenant shall pay Landlord's reasonable costs, including without limitation attorney's fees and the expenses of due diligence inquiries, incurred in connection with any request by Tenant for Landlord's consent to the assignment or sublease.

ARTICLE 9. LIABILITY, INDEMNITY AND INSURANCE

9.01 Limitation of Landlord Liability. Landlord, its officers and employees shall not be liable to Tenant for any damage to the Property or the buildings and improvements thereon, or for death or injury of any person or damage to any property, from any cause; however, this provision shall not affect the liability of Landlord, its officers and employees on any claim to the extent the claim arises from their negligence or willful misconduct.

9.02 Indemnity Generally. Tenant shall indemnify, defend, and hold harmless Landlord, its officers and employees from all claims arising from death or injury of any person or damage to any property occurring in or about the Property; however, this provision shall not apply to any claim to the extent the claim arises from the sole negligence or willful misconduct of Landlord, its officers and employees.

9.03 Indemnity for Emergency Service Costs. Without limiting the generality of Section 9.02, in the event of a major fire or other emergency, Tenant shall reimburse Landlord for the cost of providing fire fighting and other emergency service to Tenant, the Property or at any other location where the fire or emergency requiring response arises from or is related to the use of the Property or Tenant's operations. For purposes of this section, a major fire or other emergency is one that requires more than five hours of effort by the City of Homer Fire Department.

9.04 Insurance Requirements.

(a) Without limiting Tenant's obligations to indemnify under this Lease, Tenant at its own expense shall maintain in force such policies of insurance with a carrier or carriers reasonably satisfactory to Landlord and authorized to conduct business in the state of Alaska, as Landlord may reasonably determine are required to protect Landlord from liability arising from Tenant's activities under this Lease. Landlord's insurance requirements shall specify the minimum acceptable coverage and limits, and if Tenant's policy contains broader coverage or higher limits, Landlord shall be entitled to such coverage to the extent of such higher limits.

(b) Tenant shall maintain in force at all times during the Term the following policies of insurance:

(1) Comprehensive general liability insurance with limits of liability not less than a combined single limit for bodily injury and property damage of \$1,000,000 each occurrence and \$2,000,000 aggregate. This insurance also shall be endorsed to provide contractual liability insuring Tenant's obligations to indemnify under this Lease.

(2) Comprehensive automobile liability covering all owned, hired and non-owned vehicles with coverage limits not less than \$1,000,000 occurrence combined single limit for bodily injury and property damage.

(3) Workers' compensation insurance as required by AS 23.30.045. This coverage shall include employer's liability protection not less than \$1,000,000 per person, \$1,000,000 per occurrence. Where applicable, coverage for all federal acts (i.e. U.S. Longshoremen and Harbor Worker's Compensation and Jones Acts) shall also be included. The workers' compensation insurance shall contain a waiver of subrogation clause in favor of Landlord.

(4) Environmental remediation and environmental impairment liability, including sudden and accidental coverage, gradual pollution coverage, and clean-up cost coverage associated with any activity by Tenant or others on, from, or related to the Property, with coverage limits not less than \$1,000,000 for any one accident or occurrence. Coverage shall extend to loss arising as a result of the work or services or products furnished, used or handled in connection with Tenant's operations contemplated under this Lease.

(5) Property insurance covering the Required Improvements described in Section 6.02 in an amount not less than full replacement cost of the Required Improvements. The policy shall include boiler and machinery coverage.

(c) During construction of the Required Improvements and during any subsequent alteration or restoration of the Required Improvements at a cost in excess of \$250,000 per job, Tenant shall maintain builder's risk insurance in an amount equal to the completed value of the project.

(d) Tenant shall furnish Landlord with certificates evidencing the required insurance not later than the date as of which this Lease requires the insurance to be in effect. The certificates of insurance shall be attached hereto as **Exhibit G**. The certificates and the insurance policies

required by this Section shall contain a provision that coverages afforded under the policies will not be cancelled or allowed to expire, and limits of liability will not be reduced, without at least 30 days' prior written notice to Landlord. Landlord shall be named as an additional insured under all policies of liability insurance required of Tenant. Landlord's acceptance of a deficient certificate of insurance does not waive any insurance requirement in this Lease. Tenant also shall grant Landlord permission to obtain copies of insurance policies from all insurers providing required coverage to Tenant by executing and delivering to Landlord such authorizations substantially in the form of **Exhibit H** as Landlord may request.

[*ALTERNATIVE 9.04(b)(4)* — Optional provision waiving environmental insurance based on the authorized uses of Section 6.01.]

(4) Based on the authorized uses of the Property stated in Section 6.01, environmental insurance is not required. However, if Tenant uses the Property, with or without authorization from the Landlord, for purposes other than those stated in paragraph Section 6.01, if Landlord so elects, and within 10 days after Landlord gives notice of such election, Tenant shall procure and at all times thereafter maintain, at its expense, environmental remediation and environmental impairment liability, including sudden and accidental coverage, gradual pollution coverage, and clean-up cost coverage associated with any activity by Tenant or others on, from, or related to the Property, with coverage limits not less than \$1,000,000 for any one accident or occurrence. Coverage shall extend to loss arising as a result of the work or services or products furnished, used or handled in connection with Tenant's operations contemplated under this Lease.

ARTICLE 10. ENVIRONMENTAL MATTERS

10.01 Use of Hazardous Substances. Tenant shall not cause or permit the Property to be used to generate, manufacture, refine, transport, treat, store, handle, dispose of, transfer, produce or process any Hazardous Substance, except as is necessary or useful to Tenant's authorized uses of the Property stated in Section 6.01, and only in compliance with all applicable Environmental Laws. Any Hazardous Substance permitted on the Property as provided in this section, and all containers therefor, shall be handled, used, kept, stored and disposed of in a manner that complies with all applicable Environmental Laws, and handled only by properly trained personnel.

10.02 Prevention of Releases. Tenant shall not cause or permit, as a result of any intentional or unintentional act or omission on the part of Tenant or any of its agents, employees, contractors, tenants, subtenants, invitees or other users or occupants of the Property, a release of any Hazardous Substance onto the Property or onto any other property.

10.03 Compliance with Environmental Laws. Tenant at all times and in all respects shall comply, and will use its best efforts to cause all tenants, subtenants and other users and occupants of the Property to comply, with all Environmental Laws, including without limitation the duty to undertake the following specific actions: (i) Tenant shall, at its own expense, procure, maintain in effect and comply with all conditions of, any and all permits, licenses and other governmental and regulatory approvals required by all Environmental Laws, including without limitation permits required for discharge of (appropriately treated) Hazardous Substances into the ambient air or any sanitary sewers serving the Property; and (ii) except as discharged into the ambient air or a sanitary sewer in strict compliance with all applicable Environmental Laws, all Hazardous Substances from or on the Property to be treated and/or disposed of by Tenant will be removed and transported

solely by duly licensed transporters to a duly licensed treatment and/or disposal facility for final treatment and/or disposal (except when applicable Environmental Laws permit on-site treatment or disposal in a sanitary landfill).

10.04 Notice. Tenant shall promptly give Landlord (i) written notice and a copy of any notice or correspondence it receives from any federal, state or other government agency regarding Hazardous Substances on the Property or Hazardous Substances which affect or will affect the Property; (ii) written notice of any knowledge or information Tenant obtains regarding Hazardous Substances or losses incurred or expected to be incurred by Tenant or any government agency to study, assess, contain or remove any Hazardous Substances on or near the Property, and (iii) written notice of any knowledge or information Tenant obtains regarding the release or discovery of Hazardous Substances on the Property.

10.05 Remedial Action. If the presence, release, threat of release, placement on or in the Property, or the generation, transportation, storage, treatment or disposal at the Property of any Hazardous Substance (i) gives rise to liability (including but not limited to a response action, remedial action or removal action) under any Environmental Law, (ii) causes a significant public health effect, or (iii) pollutes or threatens to pollute the environment, Tenant shall, at its sole expense, promptly take any and all remedial and removal action necessary to clean up the Property and mitigate exposure to liability arising from the Hazardous Substance, whether or not required by law.

10.06 Indemnification. Subject to Section 10.09, Tenant shall indemnify, defend, and hold harmless Landlord, its officers and employees from and against any and all claims, disbursements, demands, damages (including but not limited to consequential, indirect or punitive damages), losses, liens, liabilities, penalties, fines, lawsuits and other proceedings and costs and expenses (including experts', consultants' and attorneys' fees and expenses, and including without limitation remedial, removal, response, abatement, cleanup, legal, investigative and monitoring costs), imposed against Landlord, arising directly or indirectly from or out of, or in any way connected with (i) the failure of Tenant to comply with its obligations under this Article; (ii) any activities on the Property during Tenant's past, present or future possession or control of the Property which directly or indirectly resulted in the Property being contaminated with Hazardous Substances; (iii) the discovery of Hazardous Substances on the Property whose presence was caused during the possession or control of the Property by Tenant; (iv) the clean-up of Hazardous Substances on the Property; and (v) any injury or harm of any type to any person or damage to any property arising out of or relating to Hazardous Substances on the Property or from the Property on any other property. The liabilities, losses, claims, damages, and expenses for which Landlord is indemnified under this section shall be reimbursable to Landlord as and when the obligation of Landlord to make payments with respect thereto are incurred, without any requirement of waiting for the ultimate outcome of any litigation, claim or other proceeding, and Tenant shall pay such liability, losses, claims, damages and expenses to Landlord as so incurred within 10 days after notice from Landlord itemizing in reasonable detail the amounts incurred (provided that no itemization of costs and expenses of counsel to Landlord is required where, in the determination of Landlord, such itemization could be deemed a waiver of attorney-client privilege).

10.07 Survival of Obligations. The obligations of Tenant in this Article, including without limitation the indemnity provided for in Section 10.06, are separate and distinct obligations from Tenant's obligations otherwise provided for herein and shall continue in effect after the expiration of the Term and any Renewal Term.

10.08 Claims against Third Parties. Nothing in this Article shall prejudice or impair the rights or claims of Tenant against any person other than Landlord with respect to the presence of Hazardous Substances as set forth above.

10.09 Extent of Tenant's Obligations. Tenant's obligations under this Article apply only to acts, omissions or conditions that (i) occur in whole or in part during the Term or any Extended Term or during any time of Tenant's possession or occupancy of the Property prior to or after the Term of this Lease; or (ii) are proximately caused in whole or in part by the occupancy of, use of, operations on, or actions on or arising out of the Property by Tenant or its employees, agents, customers, invitees or contractors.

10.10 Inspection at Expiration of Term. Within 90 days before the expiration of the Term or final Extended Term, Tenant shall at its own expense obtain a Phase I environmental inspection of the Property, and conduct any further inspection, including without limitation test holes, that is indicated by the results of the Phase I inspection. Tenant, at its own expense, shall remediate any contamination of the Property that is revealed by the inspections and that is Tenant's responsibility under this Article.

ARTICLE 11. CONDEMNATION

11.01 Article Determines Parties' Rights and Obligations. If any entity having the power of eminent domain exercises that power to condemn the Property, or any part thereof or interest therein, or acquires the Property, or any part thereof or interest therein by a sale or transfer in lieu of condemnation, the interests of Landlord and Tenant in the award or consideration for such transfer and the effect of the taking or transfer upon this Lease will be as provided in this Article.

11.02 Total Taking. If all of the Property is taken or so transferred, this Lease and all of Tenant's interest thereunder will terminate on the date title to the Property vests in the condemning authority.

11.03. Partial Taking. If the taking or transfer of part of the Property causes the remainder of the Property to be not effectively and practicably usable in the opinion of the Tenant for the purpose of operation thereon of Tenant's business, this Lease and all of Tenant's interest thereunder will terminate on the date title to the Property vests in the condemning authority. If the taking or transfer of part of the Property leaves the remainder of the Property effectively and practicably usable in the opinion of Tenant for the operation of Tenant's business, this Lease and all of Tenant's interest thereunder will terminate as to the portion of the Property so taken or transferred on the date title to the Property vests in the condemning authority, but will continue in full force and effect as to the portion of the Property not so taken or transferred, and the Base Rent will abate in the proportion that the portion of the Property taken bears to all of the Property.

11.04 Compensation. Landlord and Tenant each may make a claim against the condemning or taking authority for the amount of just compensation due to it. Tenant shall make no claim against Landlord for damages for termination of the leasehold or interference with Tenant's business, even if Landlord is the condemning or taking authority. Neither Tenant nor Landlord will have any rights in or to any award made to the other by the condemning authority; provided, that if a single award to Landlord includes specific damages for loss of Tenant's leasehold interest separately awarded in the eminent domain proceeding and not as a part of the

damages recoverable by Landlord, Landlord will transmit such separately awarded damages to Tenant.

ARTICLE 12. DEFAULT

12.01. Events of Default. Each of the following shall constitute an event of default under this Lease:

(a) The failure of Tenant to pay rent or any other sum of money due under this Lease within 10 days after the due date.

(b) The failure of Tenant to perform or observe any covenant or condition of this Lease, other than a default in the payment of money described in Section 12.01(a), which is not cured within 30 days after notice thereof from Landlord to Tenant, unless the default is of a kind that cannot be cured within such 30-day period, in which case no event of default shall be declared so long as Tenant shall commence the curing of the default within such 30 day period and thereafter shall diligently and continuously prosecute the curing of same.

(c) The use of the Property or buildings and improvements thereon for purposes other than those permitted herein, to which Landlord has not given its written consent.

(d) The commencement of a case under any chapter of the federal Bankruptcy Code by or against Tenant, or the filing of a voluntary or involuntary petition proposing the adjudication of Tenant as bankrupt or insolvent, or the reorganization of Tenant, or an arrangement by Tenant with its creditors, unless the petition is filed or case commenced by a party other than Tenant and is withdrawn or dismissed within ninety (90) days after the date of its filing.

(e) The admission in writing by Tenant of its inability to pay its debts when due; the appointment of a receiver or trustee for the business or property of Tenant, unless such appointment shall be vacated within 10 days after its entry; Tenant making an assignment for the benefit of creditors; or the voluntary or involuntary dissolution of Tenant.

12.02 Landlord's Remedies. Upon the occurrence of an event default, Landlord has all of the following remedies, all in addition to any other remedies that Landlord may have at law or in equity:

(a) Terminate this lease by written notice to Tenant, upon which Tenant shall surrender possession and vacate the Property immediately, and deliver possession thereof to Landlord, and Tenant hereby grants to Landlord full and free license to enter into and upon the Property in such event with or without process of law and to repossess Landlord of the Property and to expel or remove Tenant and any others who may be occupying or within the Property and to remove any and all property therefrom, using such force as may be necessary, without being deemed in any manner guilty of trespass, eviction or forcible entry or detainer, and without relinquishing Landlord's right to rent or any other right given to Landlord hereunder or by operation of law.

(b) By written notice declare Tenant's right to possession of the Property terminated without terminating this Lease, upon which Landlord will have all the rights to repossess the Property and remove Tenant and Tenant's property that are described Section 12.02(a).

(c) Subject to Section 12.01(e), relet the Property in whole or in part for any period equal to or greater or less than the remainder of the Term or Extended Term, as applicable, for any sum that Landlord may deem reasonable.

(d) Collect any and all rents due or to become due from subtenants or other occupants of the Property.

(e) Landlord may recover from Tenant, with or without terminating this Lease, actual attorney's fees and other expenses incurred by Landlord by reason of Tenant's default and elect to recover damages described under either (1) or (2):

(1) from time to time, an amount equal to the sum of all Base Rent and other sums that have become due and remain unpaid, less the rent, if any, collected by Landlord on reletting the Property reduced by the amount of all expenses incurred by Landlord in connection with reletting the Property; or

(2) immediately upon Tenant's default, an amount equal to the difference between the Base Rent and the fair rental value of the Property for the remainder of the Term or Renewal Term, discounted to the date of such default at a rate per annum equal to the rate at which Landlord could borrow funds for the same period as of the date of such default.

(f) Reentry or reletting of the Property, or any part thereof, shall not terminate this Lease, unless accompanied by Landlord's written notice of termination to Tenant.

12.03 Assignment of Rents. Tenant immediately and irrevocably assigns to Landlord, as security for Tenant's obligations under this Lease, all rent from any subletting of all or a part of the Property, and Landlord, as assignee and attorney-in-fact for Tenant, or a receiver for Tenant appointed on Landlord's application, may collect such rent and apply it toward Tenant's obligations under this Lease, except that Tenant has the right to collect such rent until the occurrence of an event of default by Tenant.

13. LEASEHOLD MORTGAGES

13.01. Mortgage of Leasehold Interest. Tenant shall have the right at any time, and from time to time, to subject the leasehold estate and any or all of Tenant's improvements situated on the Property to one or more deeds of trust, mortgages, and other collateral security instruments as security for a loan or loans or other obligation of Tenant (each a "Leasehold Mortgage"), subject to the remainder of this Article 13.

13.02 Subordinate to Lease. The Leasehold Mortgage and all rights acquired under it shall be subject and subordinate to all the terms of this Lease, and to all rights and interests of Landlord except as otherwise provided in this Lease.

13.03 Notice to Landlord. Tenant shall give Landlord notice before executing each Leasehold Mortgage, and shall accompany the notice with a true copy of the note and the Leasehold Mortgage as proposed for execution. Upon Landlord's written consent to the Leasehold Mortgage and upon execution of the Leasehold Mortgage by all parties, the mortgagee shall become a Qualified Mortgagee as that term is used in this Lease. Tenant also shall deliver to

Landlord a true and correct copy of any notice from a Qualified Mortgagee of default or acceleration of the maturity of the note secured by a Leasehold Mortgage promptly following Tenant's receipt thereof.

13.04 Modification or Termination. No action by Tenant or Landlord to cancel, surrender, or materially modify the economic terms of this Lease or the provisions of Article 11 will be binding upon a Qualified Mortgagee without its prior written consent.

13.05 Notice to Qualified Mortgagee.

(a) If Landlord gives any notice hereunder to Tenant, including without limitation a notice of an event of default, Landlord shall give a copy of the notice to each Qualified Mortgagee at the address previously designated by it.

(b) If a Qualified Mortgagee changes its address or assigns the Leasehold Mortgage, the Qualified Mortgagee or assignee may change the address to which such copies of notices hereunder shall be sent by written notice to Landlord. Landlord will not be bound to recognize any assignment of a Qualified Mortgage unless and until Landlord has been given written notice thereof, a copy of the executed assignment, and the name and address of the assignee. Thereafter, the assignee will be deemed to be the Qualified Mortgagee hereunder with respect to the assigned Leasehold Mortgage.

(c) If a Leasehold Mortgage is held by more than one person, Landlord shall not be required to give notices to the Qualified Mortgagee of the Leasehold Mortgage unless and until all of the holders of the Leasehold Mortgage give Landlord an original executed counterpart of a written designation of one of their number to receive notices hereunder. Notice given to the one so designated is effective as notice to all them.

13.06 Performance of Tenant Obligations.

(a) A Qualified Mortgagee may perform any obligation of Tenant and remedy any default by Tenant under this Lease within the time periods specified in the Lease, and Landlord shall accept such performance with the same force and effect as if furnished by Tenant; provided, however, that the Qualified Mortgagee will not thereby be subrogated to the rights of Landlord.

(b) Tenant may delegate irrevocably to a Qualified Mortgagee the non-exclusive authority to exercise any or all of Tenant's rights hereunder, but no such delegation will be binding upon Landlord unless and until either Tenant or the Qualified Mortgagee gives Landlord a true copy of a written instrument effecting such delegation.

(c) If Tenant defaults in the payment of any monetary obligation hereunder, Landlord shall not terminate this Lease unless and until Landlord provides written notice of such default to each Qualified Mortgagee and no Qualified Mortgagee cures such default within 10 days after the expiration of any grace or cure periods granted Tenant herein. If Tenant defaults in the performance of any non-monetary obligation hereunder, Landlord shall not terminate this Lease unless and until Landlord provides written notice of such default to each Qualified Mortgagee and no Qualified Mortgagee cures such default within 30 days after the expiration of any grace or cure periods granted Tenant herein.

13.07 Possession by Qualified Mortgagee. A Qualified Mortgagee may take possession of the Property and vest in the interest of Tenant in this Lease upon the performance of the following conditions:

(a) The payment to Landlord of any and all sums due to Landlord under this Lease, including without limitation accrued unpaid rent.

(b) The sending of a written notice to Landlord and Tenant of the Qualified Mortgagee's intent to take possession of the Property and assume the Lease.

(c) The curing of all defaults not remediable by the payment of money within an additional 30 days after the date upon which such default was required to be cured by Tenant under the terms of this Lease.

13.08 No Liability of Mortgagee Without Possession. A Qualified Mortgagee shall have no liability or obligation under this Lease unless and until it sends to Landlord the written notice described in paragraph 13.07(b). Nothing in this Lease or in the taking of possession of the Property and assumption of the Lease by a Qualified Mortgagee or a subsequent assignee shall relieve Tenant of any duty or liability to Landlord under this Lease.

13.09 New Lease. If a Qualified Mortgagee acquires Tenant's leasehold as a result of a judicial or non-judicial foreclosure under a Leasehold Mortgage, or by means of a deed in lieu of foreclosure, the Qualified Mortgagee thereafter may assign or transfer Tenant's leasehold to an assignee upon obtaining Landlord's written consent thereto, which consent will not be unreasonably withheld or delayed, and subject to all of the other provisions of Article 8. Upon such acquisition by a Qualified Mortgagee, or its assignee of Tenant's leasehold, Landlord will execute and deliver a new ground lease of the Property to the Qualified Mortgagee or its assignee not later than 120 days after such party's acquisition of Tenant's leasehold. The new ground lease will be identical in form and content to this Lease, except with respect to the parties thereto, the term thereof (which will be co-extensive with the remaining Term hereof), and the elimination of any requirements that Tenant fulfilled prior thereto, and the new ground lease will have priority equal to the priority of this Lease. Upon execution and delivery of the new ground lease, Landlord will cooperate with the new tenant, at the sole expense of said new tenant, in taking such action as may be necessary to cancel and discharge this Lease and to remove Tenant from the Property.

ARTICLE 14. GENERAL PROVISIONS

14.01 Authority. Tenant represents and warrants that it has complete and unconditional authority to enter into this Lease; this Lease has been duly authorized by Tenant's governing body; this Lease is a binding and enforceable agreement of and against Tenant; and the person executing the Lease on Tenant's behalf is duly and properly authorized to do so.

14.02 Estoppel Certificates. Either party shall at any time and from time to time upon not less than 30 days prior written request by the other party, execute, acknowledge and deliver to such party, or to its designee, a statement in writing certifying that this Lease is in full force and effect and has not been amended (or, if there has been any amendment thereof, that the same is in full force and effect as amended and stating the amendment or amendments); that there are no defaults

existing, (or, if there is any claimed default, stating the nature and extent thereof); and stating the dates to which the Base Rent and other charges have been paid in advance. The requesting party shall pay the cost of preparing an estoppel certificate, including the cost of conducting due diligence investigation and attorney's fees.

14.03 Delivery of Notices -Method and Time. All notices, demands or requests from one party to another shall be delivered in person or be sent by (i) mail, certified or registered, postage prepaid, (ii) reputable overnight air courier service, or (iii) electronic mail or facsimile transmission (accompanied by reasonable evidence of receipt of the transmission and with a confirmation copy mailed by first class mail no later than the day after transmission) to the address for the recipient in Section 14.04 and will be deemed to have been given at the time of delivery or, if mailed, three (3) days after the date of mailing.

14.04 Addresses for Notices. All notices, demands and requests from Tenant to Landlord shall be given to Landlord at the following address:

City Manager
City of Homer
491 East Pioneer Avenue
Homer, Alaska 99603
Facsimile: (907) 235-3148
Email: _____

All notices, demands or requests from Landlord to Tenant shall be given to Tenant at the following address:

Facsimile: _____
Email: _____

Each party may, from time to time, designate a different address or different agent for service of process by notice given in conformity with Section 14.03.

14.05 Time of Essence. Time is of the essence of each provision of this Lease.

14.06 Computation of Time. The time in which any act provided by this Lease is to be done is computed by excluding the first day and including the last, unless the last day is a Saturday, Sunday or a holiday, and then it is also excluded. The term "holiday" will mean all holidays as defined by the statutes of Alaska.

14.07 Interpretation. Each party hereto has been afforded the opportunity to consult with counsel of its choice before entering into this Lease. The language in this Lease shall in all cases be simply construed according to its fair meaning and not for or against either party as the drafter thereof.

14.08 Captions. The captions or headings in this lease are for convenience only and in no way define, limit or describe the scope or intent of any provision of this Lease.

14.09 Independent Contractor Status. Landlord and Tenant are independent contractors under this Lease, and nothing herein shall be construed to create a partnership, joint venture, or agency relationship between Landlord and Tenant. Neither party shall have any authority to enter into agreements of any kind on behalf of the other and shall have no power or authority to bind or obligate the other in any manner to any third party.

14.10 Parties Interested Herein. Nothing in this Lease, express or implied, is intended or shall be construed to give to any person other than Landlord, Tenant and any Qualified Mortgagee any right, remedy or claim, legal or equitable, under or by reason of this Lease. The covenants, stipulations and agreements contained in this Lease are and shall be for the sole and exclusive benefit of Landlord, Tenant and any Qualified Mortgagee, and their permitted successors and assigns.

14.11 Multi-Party Tenant. If Tenant is comprised of more than one natural person or legal entity, the obligations under this Lease imposed upon Tenant are joint and several obligations of all such persons and entities. All notices, payments, and agreements given or made by, with, or to any one of such persons or entities will be deemed to have been given or made by, with, or to all of them, unless expressly agreed otherwise by Landlord in writing.

14.12 Broker's Commissions. Each of the parties represents and warrants that there are no claims for brokerage commissions or finders' fees in connection with the execution of this Lease, and agrees to indemnify the other against, and hold it harmless from, all liability arising from any such claim including, without limitation, the cost of counsel fees in connection therewith.

14.13 Successors and Assigns. This Lease shall be binding upon the successors and assigns of Landlord and Tenant, and shall inure to the benefit of the permitted successors and assigns of Landlord and Tenant.

14.14 Waiver. No waiver by a party of any right hereunder may be implied from the party's conduct or failure to act, and neither party may waive any right hereunder except by a writing signed by the party's authorized representative. The lapse of time without giving notice or taking other action does not waive any breach of a provision of this Lease. No waiver of a right on one occasion applies to any different facts or circumstances or to any future events, even if involving similar facts and circumstances. No waiver of any right hereunder constitutes a waiver of any other right hereunder.

14.15 Attorney's Fees.

(a) If Landlord is involuntarily made a party defendant to any litigation concerning this Lease or the Property by reason of any act or omission of Tenant, or if Landlord is made a party to any litigation brought by or against Tenant without any fault on the part of Landlord, then Tenant shall pay the amounts reasonably incurred and expended by Landlord, including the reasonable fees of Landlord's agents and attorneys and all expenses incurred in defense of such litigation.

(b) In the event of litigation between Landlord and Tenant concerning enforcement of any

right or obligation under this Lease, the non-prevailing party shall reimburse the prevailing party for the attorney's fees reasonably incurred and expended by the prevailing party in the litigation.

14.16 Severability. If any provision of this Lease shall for any reason be held to be invalid, illegal, unenforceable, or in conflict with any law of a federal, state, or local government having jurisdiction over this Lease, such provision shall be construed so as to make it enforceable to the greatest extent permitted, such provision shall remain in effect to the greatest extent permitted and the remaining provisions of this Lease shall remain in full force and effect.

14.17 Entire Agreement, Amendment. This Lease constitutes the entire and integrated agreement between Landlord and Tenant concerning the subject matter hereof, and supersedes all prior negotiations, representations or agreements, either written or oral. No affirmation, representation or warranty relating to the subject matter hereof by any employee, agent or other representative of Landlord shall bind Landlord or be enforceable by Tenant unless specifically set forth in this Lease. This Lease may be amended only by written instrument executed and acknowledged by both Landlord and Tenant.

14.18 Governing Law and Venue. This Lease will be governed by, construed and enforced in accordance with, the laws of the State of Alaska. Any action or suit arising between the parties in relation to or in connection with this Lease, or for the breach thereof, shall be brought in the trial courts of the State of Alaska for the Third Judicial District at Homer.

14.19 Execution in Counterparts. This Lease may be executed in two or more counterparts, each of which shall be an original and all of which together shall constitute one and the same document.

[OPTIONAL SPECIAL PROVISIONS] -- 14.20 prior lease amended and superseded

14.20 Prior Lease. Landlord and Tenant are parties to a prior lease affecting the Property dated _____, 19__, a memorandum of which has been recorded in the records of the Homer Recording District under Document No. _____ (the "Prior Lease"). This Lease replaces and supersedes the Prior Lease effective as of _____, 201_, and on and after that date the Prior Lease shall have no force or effect, except that it shall remain in effect as to events, rights, obligations, or remedies arising or accruing under the Prior Lease prior to that date.

IN WITNESS WHEREOF, the parties have executed this Lease as of the date first set forth above.

Landlord:

CITY OF HOMER

By: _____
Walt Wrede, City Manager
(name/title)

Tenant:

By: _____

ACKNOWLEDGMENTS

STATE OF ALASKA)

) ss.

THIRD JUDICIAL DISTRICT)

The foregoing instrument was acknowledged before me on _____, 201__, by Walt Wrede, City Manager of the City of Homer, an Alaska municipal corporation, on behalf of the City of Homer.

Notary Public in and for Alaska
My Commission Expires: _____

STATE OF ALASKA)

) ss.

THIRD JUDICIAL DISTRICT)

The foregoing instrument was acknowledged before me on _____, 201__, by _____, as _____ (title) of _____ (name of entity) on behalf of _____ (name of entity).

Notary Public in and for Alaska
My Commission Expires: _____

EXHIBIT A

**SCHEDULE OF ORGANIZATION, OWNERS,
PERCENTAGE OF OWNERSHIP**

Tenant, _____, is a _____ organized under the laws of the state of _____. Attached to this exhibit is a certificate issued by that state certifying that Tenant is in good standing and describing its legal organization. If Tenant is a foreign entity authorized to conduct business in Alaska, its certificate of authority is also attached

The _____ (specify whether shareholders, partners, members, etc.) and their percentage of ownership are as follows:

| | |
|----------------|---------|
| Name _____ | _____ % |
| Address: _____ | |
| Name _____ | _____ % |
| Address: _____ | |
| Name _____ | _____ % |
| Address: _____ | |
| TOTAL | 100 % |

EXHIBIT B

**CONFORMED COPY OF RESOLUTION AUTHORIZING LEASE AND
AUTHORIZING SIGNERS TO SIGN LEASE AGREEMENT ON BEHALF
OF TENANT**

EXHIBIT C
LOCATION OF PROPERTY
(Section 2.01)

EXHIBIT D

TENANT'S PROPOSED USE OF THE PROPERTY

(Section 6.01)

EXHIBIT D

EXHIBIT E
SITE PLANS
(Section 6.02)

EXHIBIT F
FLOOR PLANS
(Section 6.02

EXHIBIT G

CERTIFICATES OF INSURANCE

(Section 9.04(d))

EXHIBIT G
Page 2 of 2

EXHIBIT G

Page 34 of 35

CITY OF HOMER
GROUND LEASE &
SECURITY AGREEMENT

EXHIBIT H

PERMISSION TO OBTAIN INSURANCE POLICIES

(Section 9.04(d))

The City of Homer is hereby granted permission to request and obtain copies of _____ ("Tenant") insurance policies from Tenant's broker and/or insurer, _____. Tenant requests the broker/insurer to provide the City of Homer with information about and copies of all of Tenant's insurance policies providing the type of coverage required by the Lease between Tenant and the City of Homer.

It is understood that the Tenant may revoke this permission at any time by written notice to City of Homer and to Tenant's broker and/or insurer; however, such revocation will constitute a default of Tenant's lease from the City of Homer.

Date: _____

TENANT NAME

By:

_____ (printed name)
_____ (title)

By: _____
_____ (printed name)
_____ (title)

CITY OF HOMER
PROPERTY MANAGEMENT
POLICY AND PROCEDURES

Table of Contents

CHAPTER 1:
Lease Policies / Goals, Purpose, and Responsibility.....3

CHAPTER 2:
Lease Committee.....4

CHAPTER 3:
Properties Available for Lease.....5

CHAPTER 4:
RFP Process / Competitive Bidding.....7

CHAPTER 5:
Lease Application Process.....8

CHAPTER 6:
Application / Proposal Evaluation Process.....9

CHAPTER 7:
Lease Rental Rates.....10

CHAPTER 8:
Reconsideration.....11

CHAPTER 9:
Lease Implementation.....12

CHAPTER 10:
Improvements.....14

CHAPTER 11:
Length of Leases / Options.....15

CHAPTER 12:
Lease Rate Adjustments.....17

CHAPTER 13:
Sub-Leasing.....18

CHAPTER 14:
Assignments.....20

CHAPTER 15:
Insurance.....21

CHAPTER 16:
Hazardous Materials.....23

CHAPTER 17:
Performance Standards.....24

CHAPTER 18:
Conclusion of Lease.....25

CHAPTER 19:
Surplus Equipment Disposal.....

APPENDICES:

Homer City Code / Chapter 18.08 – City Property Leases. last amendment, Ordinance 04-22

- Resolution 04-25(A), adopted April 26, 2004.
- Resolution 07-25(A), adopted June 25, 2007.
- Resolution 10-77(A), adopted September 27, 2010.
- Resolution 14-82(A), adopted July 28, 2014.

CITY OF HOMER
PROPERTY MANAGEMENT
POLICIES AND PROCEDURES

CHAPTER 1: LEASE POLICIES / GOALS, PURPOSE, AND RESPONSIBILITY

1.1 GOALS AND PURPOSE

- A. The property lease management policies contained herein are authorized by HCC 18.08 and are intended to provide guidance, clarity, and standardization for all leasing activities on City owned property.
- B. It is the policy of the City of Homer to lease property when it is in the overall best interest of the City to do so. The City will seek to maximize the value of its assets and lease property for the highest and best use.
- C. It is the policy of the City to implement its leasing program in a fair and nondiscriminatory manner. Opportunities for long term leases on City owned properties will be made available to the public through the RFP process described herein.
- D. It is the policy of the City to lease property for a specific purpose or use. Leasing for the purpose of speculation and/or subleasing land will be discouraged.

1.2 RESPONSIBILITY

- A. The Lease Committee described herein shall be responsible for reviewing this policy manual and making recommendations to the City Council as needed, advising the City Manager or designee as to terms, stipulations, and negotiating approach with respect to leases, evaluating lease applications, and making recommendation to the City Council regarding proposed leases.
- B. The City Manager or designee is responsible for all lease negotiation activities and for implementing and administering the lease policies and procedures.
- C. The City Council has responsibility for approving and adopting the lease policies and for final approval of all leases over six months in duration.

CITY OF HOMER
PROPERTY MANAGEMENT
POLICIES AND PROCEDURES

CHAPTER 2: LEASE COMMITTEE

2.1 POLICY

A. It is the policy of the City of Homer to establish and maintain a Lease Committee.

2.2 PROCEDURES

A. The City Manager shall establish a Lease Committee that will consist of the Finance Director, the City Planner, the Port and Harbor Director, one member of the Economic Development Commission, one member of an additional commission as determined appropriate by the City Manager, and one member of the public. The Manager shall consult with the Chair of the Commissions to determine who from the Commission and who from the public might best serve the Committee and not be subject to conflicts of interest. The Lease Committee may consult with other department heads such as, the Fire Chief, Police Chief and the Public Works Director and the City Manager or outside professionals as needed and appropriate.

B. The Lease Committee is responsible for:

- Reviewing the Lease Policies and Procedures as needed and making recommendations to the City Council. Prior to making recommendations to the City Council on the Lease Policies and Procedures, the Lease Committee shall consult with and seek comments from the Port and Harbor Advisory Commission when the lease property is on land on the Homer Spit surrounding the Port and Harbor area.
- Advising the City Manager or designee as to the terms, purposes, stipulations and negotiation approach to proposed leases
- Reviewing all proposed leases and making recommendations to the City Council.

C. In all cases, the Lease Committee shall make recommendations that are consistent with this policy and procedures manual or make specific findings as to why a deviation is warranted and justified.

CITY OF HOMER
PROPERTY MANAGEMENT
POLICY AND PROCEDURES

CHAPTER 3: PROPERTIES AVAILABLE FOR LEASE

3.1 POLICY

- A. It is the policy of the City of Homer to provide property for lease through a fair, nondiscriminatory, and standardized process that the public can readily understand and support.
- B. It is the policy of the City that public land shall be leased in a way that maximizes the value of City assets, promotes activities and uses that are in the overall best interest of the City, and are consistent with the Comprehensive Plan.

3.2 PROCEDURES

- A. The Lease Committee shall maintain a list of all City properties that have been authorized for lease by the City Council. This list shall be made readily available to the public. The Lease Committee may also develop a list of additional properties, for City Council review, that it recommends should be made available for lease.
- B. The City Council shall identify which City properties are available for lease through its annual land allocation workshop process which includes the Lease Committee, the Planning Commission, the Port and Harbor Commission, and the Parks and Recreation Commission.
- C. All properties identified as available for lease by the City Council shall be subject to the lease policies and procedures contained herein.
- D. All uses and activities on lands made available for lease are subject to the City Comprehensive Plan, zoning ordinances, flood ordinance, subdivision ordinance, and other applicable local, state, and federal laws and regulations.
- E. The City Council may restrict specific City properties to certain uses or classes of use. Such properties will be available for leasing only such uses. The City Council has in the past restricted the use of lots immediately adjacent to the Fish Dock to activities directly related to commercial fishing. Similarly, it has restricted uses on lots adjacent to the Deep Water Dock to marine industrial uses with an emphasis on shipping and cargo handling. The purpose for these restrictions is to encourage growth in targeted economic sectors, to insure that the City receives the maximum benefits from the large investment the public has made in those docks, and to provide land for businesses that require close proximity to the docks in order to operate efficiently and profitably.

CITY OF HOMER
PROPERTY MANAGEMENT
POLICY AND PROCEDURES

CHAPTER 4: REQUEST FOR PROPOSALS (RFP)

4.1 POLICY

- A. It is the policy of the City of Homer that a request for proposals, or a competitive bidding process be used for the leasing of City owned property. Exceptions to this policy may be made by the City Council as per section 10.2.E of these policies and/or under special or exceptional circumstances. The Council shall review recommendations of the Lease Committee and, if an exception is granted, adopt a resolution finding that it is in the public interest and approving the exception.

4.2 PROCEDURES

- A. Properties that are available for lease will be advertised by the Lease Committee through the normal City of Homer public notice process a minimum of one time per year. The Lease Committee shall provide such notice within 60 days of the completion of the annual land allocation process and adoption by the Council of the Land Allocation Plan. The committee may advertise more frequently as needed and appropriate.
- B. Requests for Proposals shall be solicited by the Lease Committee during a time frame identified in the advertisements and proposal submittal documents.
- C. The criteria used to score and rank proposals shall include, but not necessarily be limited to, the criteria listed in the evaluation chapter herein.
- D. The Lease Committee shall review, evaluate, score, and rank all responsive proposals and make recommendations to the Manager. If none of the responsive proposals is satisfactory, the Lease Committee may recommend against all of the proposals. The manager shall notify the City Council of the Committee's recommendations.
- E. The Lease Committee must obtain approval from the City Council before requesting proposals to lease property that is not on the approved list of properties available for lease.
- F. The City Council may by resolution in particular cases approve other bidding or proposal procedures or exceptions to these procedures.

CITY OF HOMER
PROPERTY MANAGEMENT
POLICY AND PROCEDURES

CHAPTER 5: LEASE APPLICATION PROCESS

5.1: POLICY

- A. It is the policy of the City of Homer to provide for a streamlined, standardized, and easily understood lease application process. A full and complete application packet shall be provided to all applicants. Applicants must be qualified under Section 18.08.50 of the Homer City Code.
- B. The City administration will provide for pre-application meetings with all potential applicants to provide relevant information on things like land use regulations, lease policies, the permitting process, and other relevant topics.

5.2 PROCEDURES

- A. A responsive lease application / proposal shall include:
 - 1. A completed application form provided by the City
 - 2. Any applicable fees
 - 3. A clear and precise narrative description of the proposed use of the property
 - 4. A specific time schedule and benchmarks for development
 - 5. A proposed site plan drawn to scale that shows at a minimum property lines, easements, existing structures and other improvements, utilities, and the proposed development including all structures and their elevations, parking facilities, utilities, and other proposed improvements.
 - 6. Any other information that is directly pertinent to the proposal scoring criteria contained herein
 - 7. All other required attachments requested on the application form including, but not limited to, the following documentation: applicant information, plot plan, development plan, insurance, proposed subleases, environmental information, agency approvals and permits, fees, financial information, partnership and corporation statement, certificate of good standing issued by an entity's state of domicile, and references.
 - 8. Any other information required by the solicitation or request for proposals.

CITY OF HOMER
PROPERTY MANAGEMENT
POLICY AND PROCEDURES

CHAPTER 6: APPLICATION / PROPOSAL EVALUATION PROCESS

6.1 POLICY

- A. It is the policy of the City of Homer to provide for a fair, standardized and objective proposal evaluation process.

6.2 PROCEDURES

- A. All lease proposals shall be evaluated and scored by the Lease Committee.
- B. The Criteria for evaluating proposals shall include but is not limited to the following:
 - 1. Compatibility with neighboring uses and consistency with applicable land use regulations including the Comprehensive Plan.
 - 2. The development plan including all proposed phases and timetables.
 - 3. The proposed capital investment.
 - 4. Experience of the applicant in the proposed business or venture.
 - 5. Financial capability or backing of the applicant including credit history, prior lease history, assets that will be used to support the proposed development.
 - 6. The number of employees anticipated.
 - 7. The proposed rental rate.
 - 8. Other financial impacts such as tax revenues, stimulation of related or spin-off economic development, or the value of improvements left behind upon termination of the lease.
 - 9. Other long term social and economic development.
- C. Lease Rental Rates
 - 1. The determination of lease rental rates is addressed in Chapter 7.
- D. After evaluating and scoring the proposals, the Lease Committee shall make a recommendation on a successful bidder to the City Council. The recommendation shall be contained in the form of a memorandum from the City Manager to the City Council that appears on the consent calendar of a regular meeting agenda. If a recommendation to approve a proposal is adopted, the Manager or his designee shall finalize a lease document for presentation to Council for approval. If the Council approves the lease, it will not be executed until the period for reconsideration under section 8.3 passes.
- E. Prior to submitting a recommendation from the Lease Committee to the City Council on a lease proposal or successful bidder when the lease property is on land on the Homer Spit surrounding the Port and Harbor area, the City Manager shall provide the recommendation to the Port and Harbor Advisory Commission for review and comment. The Commission may, at its discretion, provide

recommendations to the City Manager and to the City Council. After receiving the Commission recommendations, the City Manager may refer the matter back to the Lease Committee if appropriate and warranted.

- F. Final approval of long term leases (more than six months) rests with the City Council. The Council shall either:
 - 1. Approve the proposed lease
 - 2. reject the proposed lease; or
 - 3. remand the unapproved lease to the Manager with comments

CITY OF HOMER
PROPERTY MANAGEMENT
POLICY AND PROCEDURES

CHAPTER 7: Lease Rental Rates

7.1 POLICY

It is the policy of the City of Homer to provide for a lease rental rate structure that stimulates business activity, promotes the best use of City land, and maximizes the value of City owned real property.

7.2 PROCEDURES

A. Lease Rental Rates Generally

1. All property shall be leased at no less than “fair market rent”. Fair market rent is defined as the rental income that a public and private property would most likely command in the open market; indicated by the current rents paid for comparable space as of the date of the appraisal.
2. Payment of a higher than market rent resulting from an applicant’s proposal is generally in the public interest and will help to establish fair market rent using current market forces.
3. The City Council may establish a minimum rent or “asking price.” It may set the minimum rent at an amount equal to or higher than the estimated “fair market rent” if it finds that it is in public interest to do so. It may set uniform rental rates for a class of similar properties that remain available for leasing after the conclusion of a competitive lease offering.
4. The Council may approve a lease of City land for less than fair market rent, minimum rent, or uniform rental rate only if the motion approving the lease contains a finding that the lease is for a valuable public purpose or use, and a statement identifying such public purpose or use.

- B. Rental Rate Determination: Lease rental rates shall be determined by periodic appraisals scheduled and paid for by the City.

CITY OF HOMER
PROPERTY MANAGEMENT
POLICY AND PROCEDURES

CHAPTER 8: RECONSIDERATION

8.1 POLICY

It is the policy of the City of Homer to provide for a reconsideration process so that a fully responsive bidder may seek remedies to actions by the City Council that he or she may believe are in error, unfair, or otherwise unsatisfactory. The reconsideration provisions apply only to final approval of a lease by the City Council.

8.2 RESPONSIBILITY

- A. The City Council is responsible for hearing reconsiderations and for making the final determination on them.
- B. The City Manager is responsible for providing all required staff support necessary to assist the Council in hearing and deciding reconsiderations.

8.3 PROCEDURE

- A. A fully responsive bidder who believes that the City Council final action on the terms of a proposed lease is unsatisfactory may request a reconsideration.
- B. Reconsideration Process:
 - 1. A written request for reconsideration must be filed by a fully responsive bidder with the City Clerk within 15 days of the City Council action which is to be reconsidered. Any decision for which reconsideration is not requested within that period shall become final.
 - 2. The City Clerk shall schedule the matter for reconsideration before the City Council at an appropriate regular meeting.
 - 3. The person requesting reconsideration and all parties involved in the Council action to be reconsidered, shall be notified by the Clerk of the reconsideration request and the date upon which the Council will reconsider. Such notice shall be given not less than 15 days prior the scheduled reconsideration.
 - 4. An electronic tape recording shall be kept of the entire reconsideration proceeding and typewritten minutes shall be prepared. The electronic tape recording shall be preserved according to the City's records retention policy at the time.
 - 5. The decision of the City Council on reconsideration shall be final. There shall be no appeal.

CITY OF HOMER
PROPERTY MANAGEMENT
POLICY AND PROCEDURES

CHAPTER 9: LEASE IMPLEMENTATION

9.1 POLICY

It is the policy of the City of Homer that all leases shall be negotiated and administered in a fair, standardized, and professional manner that is consistent with the Homer City Code and these policies and procedures.

9.2 PROCEDURES

- A. The Lease Committee and the City Manager shall develop a standardized ground lease document that contains standard provisions applicable to all ground leases. Similarly, the Lease Committee and the City Manager may develop one or more standardized building leases (as many as necessary to apply to each City building available for leasing) containing standard provisions applicable to all leases of space in a city building. The standard lease documents shall be reviewed by the City attorney and approved by the City Council. Standard lease documents provide the baseline requirements and conditions of all city leases. They are the starting point in negotiations and are subsequently structured and modified to meet the specifics of the development proposal with respect to things like term, lease rate, allowed uses, required insurance, and so on.
- B. The terms and conditions of each lease shall be reviewed by the Lease Committee prior to execution. The committee shall make recommendations on terms and conditions to the Manager and the City Council.
- C. The City Manager or designee is responsible for lease negotiations, including any negotiated changes in the standard lease terms. The Manager shall take into consideration the following when negotiating the terms of a lease:
 - 1. the nature of the proposed use
 - 2. the type and cost of the improvements to be placed on the property
 - 3. the period of time required to amortize the improvements
 - 4. the overall benefit to the City
 - 5. consistency with the Comprehensive Plan and all other relevant land use codes and regulations
 - 6. the public need and benefit
 - 7. the date of commencement and completion of improvements
 - 8. the value and usefulness of buildings, structures, and other permanent improvements that will remain on the City's land after termination of the lease.
 - 9. other factors deemed relevant by the Lease Committee or the City Manager.
- D. The determination of lease rental rates is addressed in Chapter 7.

- E. All leases and attachments, or in the direction of the City Manager a memorandum of lease, shall be recorded in the proper recording office by the Clerk's office. The Lessee is responsible for the recording fees.
- F. All leases must require the lessee to comply with applicable zoning, parking, sign, flood, and other pertinent local ordinances and state and federal statutes and regulations.
- G. If a lease is awarded, an as-built survey including elevations performed by an RPLS(Registered Professional Land Surveyor) shall be provided to the City within 6 months of completion of permitted or required development or requirements under the lease. Each additional structure or significant improvement shall require an additional or updated as-built except that the Manager may waive the RPLS requirement. The lessee will be required to subdivide and replat city owned parcels if the lease so requires. All surveys are to be provided by the lessee at his/her expense.
- H. At the time each as-built is submitted, a statement of value including leaseholds and all improvements shall be provided. The Statement of Value shall be either a letter of opinion or appraisal completed by an Alaska Certified General Appraiser.
- I. All development requirements and performance standards contained in the lease shall be strictly enforced and if not complied with or negotiated for modification as per 10.2.B, shall be cause for the lease to be terminated.

CITY OF HOMER
PROPERTY MANAGEMENT
POLICY AND PROCEDURES

CHAPTER 10: IMPROVEMENTS

10.1 POLICY

It is the policy of the City of Homer that all improvements installed, maintained, occupied, and used on leased City property shall be strictly monitored and shall be consistent with the terms and conditions of the lease and all other applicable codes and regulations.

10.2 IMPLEMENTATION

- A. Construction of improvements on leased properties shall take place only after review and approval of the construction plans by the Lease Committee and all applicable permits and legal requirements are secured.
- B. Construction of improvements that are not consistent with the lease agreement are prohibited unless they are approved by an amendment to the lease approved by the City Council. The amendment is subject to the same review process as initial leases.
- C. All improvements constructed upon leased property become the property of the City upon termination of the lease unless otherwise provided in the lease, or agreed to by the parties in writing, the lessee shall on or before the lease termination date remove all improvements the lessee is authorized or required to remove and restore the property to the same condition it was in at the time the lease was executed by the lessee.
- D. Lessee shall be responsible for all municipal property taxes on the leasehold interest in the real property and improvements and sales taxes on the rent payments.

CITY OF HOMER
PROPERTY MANAGEMENT
POLICY AND PROCEDURES

CHAPTER 11: LENGTH OF LEASES / OPTIONS

11.1 POLICY

It is the policy of the City of Homer that the duration of all leases including all options shall be consistent with the provisions of Chapter 18.08 of the Homer City Code and the provisions of these policies and procedures.

11.2 PROCEDURES

- A. The initial term of leases shall be related to a large degree upon the magnitude of the lessee's financial investment and the value and usefulness of improvements that lessee will make and leave on the property upon the termination of the lease. It shall also be related, to a lesser degree, upon lessee's financing and the reasonable amortization requirements of the lessee and financing agency. Generally speaking, the larger the investment, and the greater the value and usefulness of permanent improvements that will remain on the property after termination of the lease, the longer the lease period.
- B. Leases that extend beyond 30 years (including all options) will be treated as exceptional and shall be evaluated on a case by case basis.
- C. Leases shall contain no more than two options for renewal and each option shall be for no more than 25% of the length of the initial base term. The exercise of any option shall be dependent upon lessee not being in breach of any provisions of the lease at that time.
- D. If the lease or the lessee's approved development plan provides for utilization of the lot for several months a year and the lessee installs improvements or infrastructure, occupies the lot (by persons or things), or does anything else that precludes or devalues utilization of the lot for the remainder of the year by the City or another party, the lessee shall pay either a premium rent for the months the parcel is actually in use or fair market rental for the entire lease year.
- E. It is the policy of the City that equal opportunities should be provided to compete for leasing available public property. A lessee whose initial lease and all options have expired shall have no automatic right of further renewal or extension. In general, it is the policy of the City that the Lease Committee shall offer such properties to the public through the RFP/competitive bidding process described herein.
- F. Lease Renewals: The City Council, after reviewing a recommendation from the Lease Committee, may elect to not require a competitive bidding process for a property whose lease has expired (including all options) if it finds that it is in the best interest of the City to enter into a new lease agreement with the current lessee. If the current lessee is interested in entering into a new lease agreement, he/she must indicate so in writing to the City Manager at least 12 months prior to

the expiration of the lease and submit a formal lease application/proposal for evaluation by the Lease Committee. The City will review the application but is under no obligation to enter into a new lease. If the Council chooses to approve such a new lease without a competitive process, it must approve such new lease by resolution within six months that includes a finding that it is in the public interest to do so, after consideration of relevant facts including, but not limited to, the following:

1. The lessee's past capital investment and binding commitment to future capital investment
2. The lessee's financial condition and prior lease history
3. The number of persons employed and the prospects for future employment
4. Tax revenues and other financial benefits to the City of Homer anticipated in the future if the lease is renewed.
5. Consistency of the past use and intended future use with all applicable land use codes and regulations, the Comprehensive Plan, and Overall Economic Development Plan
6. Other opportunities for use of the property that may provide greater benefits to the City of Homer.
7. Other social, policy, and economic considerations as determined by the Council

G. Short Term Leases

1. A short term lease of 6 months or less may be approved by the City Manager after review and recommendations by the Lease Committee.
2. Short term leases are not required to go through the competitive bidding/PFP process described herein
3. Short term leases shall not include renewable options and no consecutive short term leases for the same property to the same lessee may be issued without the approval of the City Council.
4. Applicants for short term leases must go through the formal application process described herein.
5. The City Manager will advise the Council through memorandum or the Manager's report of all short term leases.

H. At the expiration or termination of a lease the City may negotiate to reimburse the lessee for improvements at fair market value, and then issue a request for proposals offering the lot and improvements as a package.

CITY OF HOMER
PROPERTY MANAGEMENT
POLICY AND PROCEDURES

CHAPTER 12: LEASE RATE ADJUSTMENTS

12.1 POLICY

It is the policy of the City of Homer to adjust lease rental rates from time to time in order to compensate for inflation, increases in the cost of living, and changing real estate market conditions.

12.2 PROCEDURES

- A. All leased properties shall be appraised every fifth year. The appraisal shall be conducted by an Alaska Certified General Real estate Appraiser. Appraisals shall be subject to the following:
 - 1. The lease rate shall be adjusted upward based upon increased property appraisal values. This periodic adjustment compensates for changing market conditions in the area by determining the fair rental value. In the event that an appraisal reveals that fair market rent has declined, the lessee may petition the City for an amendment to the lease and reduction in the lease rate. The City is under no obligation to do so. Any reduction in lease rates must be approved by the City Council and the motion to do so must include a statement regarding why the action is in the public interest.
 - 2. During the month of January each year, the City will contract with an Alaska Certified General Real Estate Appraiser to appraise all leased parcels which are due for their five year appraisals in that year. The appraisals will be bundled and conducted at the same time under the same contract in order to reduce costs. The City will select the appraiser and bear the cost of the appraisal.
 - 3. The newly adjusted lease rate determined by the appraisal will take effect on the anniversary date of the lease.
- B. In addition, all rental rates shall be adjusted annually based upon changes in the Anchorage Consumer Price Index (CPI). No CPI adjustments shall be made in the initial year of the lease or in any year in which an appraisal adjustment occurs.

CITY OF HOMER
PROPERTY MANAGEMENT
POLICY AND PROCEDURES

CHAPTER 13: SUB-LEASES

13.1 POLICY

It is the policy of the City of Homer that City land should be leased for a specific use or purpose approved by the City. City land shall not be leased for the purpose of speculation. Individual business structures unrelated to the primary permitted use that are owned by the lessee or subtenants of the lessee shall be discouraged.

13.2 PROCEDURES

- A. If a potential lessee intends to sub-lease City owned property, this intention shall be clearly stated and described in the original lease application and proposal.
- B. In order for a sub-lease to be approved, the right to sub-lease, and the terms and conditions thereon, must be specifically included and stated in the underlying base lease.
- C. All sub-leases must be in writing and executed by the parties. All sub-leases must be approved by the City Council after a recommendation is provided by the City Manager and the Lease Committee. Approval must be granted prior to occupancy of the leased premises by the sub-tenant.
- D. All amendments to sub-leases must be in writing and approved by the City Council prior to becoming effective.
- E. Sub-leasing shall not be used as a method to accomplish the transfer of interest in the entire leasehold.
- F. All sub-leases must comply with applicable zoning, parking, sign, flood, and other applicable local ordinances and state and federal statutes.
- G. All sub-leases are subject to the base lease and all sub-tenants must comply with the relevant provisions of the base lease as identified by the Lease Committee. Sub leases of City land are subject to additional rent pursuant to HCC 18.08.120.
- H. Sub-leasing within a building may be approved provided that the terms and conditions of such are clearly set out and described in the original base lease.
- I. Partnerships: The City may consider and approve a lease and development plan that consists of two or more independent businesses that finance, construct, and occupy the same building or improvements. The businesses, business relationship, and proposed uses must be approved by the City in advance. Partnerships such as this are not considered to be a sub-lease.
- J. Developers/Investors: The City may consider proposals from developers who wish to construct buildings and/or other improvements for the purpose of sub-leasing, if all tenants of the building or land are engaged in activities that are permitted by applicable zoning codes and restricted uses as approved by the Council in effect at the time. The lessee will be in violation of the lease if he/she sub-leases for uses other than those permitted by the lease.

13.3 PROCEDURES

- A. If a lessee with an assignable lease wishes to assign, the City must first make a determination that the lessee is current and not in default with respect to lease payments, taxes, and other fees that may be owing, and in compliance with any other relevant terms and conditions of the base lease. If the lessee is in good standing and eligible to assign, the following procedures will apply.
- B. The lessee shall request approval of lease assignment in written form and submit a lease assignment document(s) to the Lease Committee.
- C. The Lease Committee shall review the request and assignment document(s), determine whether the proposed assignee is qualified under HCC 18.08.050, and meet with assignee to ascertain whether the assignment would be beneficial to the interests of the City.
- D. The assignee shall submit a new lease application form complete with all attachments and proposals following the process described herein for lease applications, and submit it along with any applicable fees to the Lease Committee for review.
- E. The Lease Committee shall review the application and proposal using the application evaluation criteria described herein.
- F. The Lease Committee shall make a recommendation on the assignment to the City Council for final action.

CITY OF HOMER
PROPERTY MANAGEMENT
POLICIES AND PROCEDURES

CHAPTER 14: ASSIGNMENTS

14.1 POLICY

It is the policy of the City of Homer to incorporate an assignment provision into the lease document if that is requested by the lessee. Consent to an assignment request shall be conditioned upon receipt of all current and applicable payments and properly submitted documentation. The proposed assignee must also be acceptable to the City of Homer and commit to develop and use the property in a manner acceptable to the City.

14.2 DEFINITIONS

- A. Assignable lease: A lease which contains a provision permitting its assignment by lessee.
- B. Assignment: A transfer of interests or rights to property, real or personal, in possession or in action, or of any estate or right therein. The assignment of a lease is distinguishable from a sublease to the extent that in assigning, the lessee transfers his entire interest and estate in the premises, whereas, in a sublease, the sublessee acquires something less than the lessee's entire interest.

14.3 RESPONSIBILITY

- A. The Lease Committee is responsible for reviewing assignment provisions that may be included in lease documents. The Lease Committee is also responsible for reviewing and making recommendations to the City Council on all requests to assign a City lease.
- B. The City Council is the final authority on all requests to assign.
- C. The City Council may approve assignment of a lease to banks or other financial institutions for financing or other reasons if it determines that to be in the best interest of the City.

14.4 ASSIGNMENT WITH SALE OF BUSINESS

Where a lessee intends to assign the lease as part of a sale of the business located on the lease lot, the person who intends to purchase the business may apply to extend the lease term to allow the continuation of the business and to secure financing for the purchase.

CITY OF HOMER
PROPERTY MANAGEMENT
POLICY AND PROCEDURES MANUAL

CHAPTER 15: INSURANCE

15.1 POLICY

It is the policy of the City of Homer to require lessees to carry general public liability insurance, environmental insurance if appropriate, workers compensation insurance, and any other insurance coverage determined to be necessary by the City in order to protect City assets and the public interest.

15.2 PROCEDURES

- A. All lessees shall keep in force for the full term of the lease public liability insurance in the amount of not less than \$1 million coverage per occurrence for bodily injury (including death) and property damage. The City of Homer shall be named as an additional insured.
- B. Lessees who intend to conduct activities which could potentially have significant risk of environmental contamination shall also obtain not less than \$2 million in environmental insurance (Environmental Impact Insurance and/or Environmental Clean-up Policy, or the equivalent subject to review and approval by the City Manager) with the City of Homer as an additional insured. Environmental Insurance for the purposes of City leasing procedures shall meet the standards of the Environmental Insurance Requirement document attached as Appendix A to these policies. The following procedures apply in determining whether a significant risk of environmental contamination is present:
 1. The City will determine on a case by case basis whether a lease of City property will involve a significant risk of environmental contamination due to the use of the property, the presence of hazardous materials, or the location of the property.
 2. If the City determines that a significant risk is present, the environmental insurance requirement shall apply.
 3. Recommendations by the Manager and Lease Committee on environmental insurance are subject to final approval by the Homer City Council through the lease approval process.
 4. The following are examples of uses that generally will not involve a significant risk of environmental contamination. This list is not exhaustive or all inclusive and is provided for illustrative purposes only: restaurants, retail/charter businesses, commercial fishing gear storage (provided the storage does not include fuels, lubricants, hydraulic fluids, and solvents, or machinery containing any of them, campgrounds, entertainment establishments, drinking establishments, and the ordinary use of commonly used household cleaning agents and office products.

5. The following are examples of uses that generally will involve a significant risk of environmental contamination. This list is not exhaustive and is provided for illustrative purposes only: a) Storage or processing of logs, chips & other wood products, b) sale, manufacture, distribution, fueling of equipment, or storage of petroleum products, c) repair shops involving the use of solvents, d) activities in the tidelands or in close proximity to environmentally sensitive areas, e) the use of drums to collect, transport, or store waste oil, solvents, or other hazardous materials, f) the use of hazardous materials in manufacturing or processing, g) storage of hazardous waste in quantities sufficient to trigger reporting obligations under the Resource Conservation and Recovery Act, h) outside use or storage of equipment with a risk of leaking fuels, lubricants, solvents or hydraulic fluid.
- C. Certificates of Insurance showing the required insurance is in effect and identifying the City of Homer as an additional insured shall be provided to the City of Homer initially at the time a lease becomes effective and annually thereafter, and upon every change in insurance provider or insurance coverage.
- D. All insurance policies must be in effect for the duration of the lease term, or longer if stated in the lease, and the City must be notified of any changes to policies.

CITY OF HOMER
PROPERTY MANAGEMENT
POLICY AND PROCEDURES MANUAL

CHAPTER 16: HAZARDOUS MATERIALS

16.1 POLICY

It is the policy of the City of Homer to require that all lessees on City owned property take the precautions necessary to protect city property and the surrounding environment from pollution and contamination. All leases of City property, whether they are subject to the Environmental Insurance Requirement or not, shall include terms which impose the minimum requirements for environmental protection set out below.

16.2 PROCEDURES

- A. The lessee shall not allow hazardous materials to be used or kept on City property, except as specifically permitted or necessary for the lessee's lawful use and approved of the property.
- B. The lessee's use of hazardous materials, if permitted, shall comply will all applicable laws and regulations.
- C. The lessee shall not pollute or contaminate the environment with discharges, leaks, or emissions of hazardous materials.
- D. The lessee shall be required to promptly notify the appropriate authorities and the City of any discharge or spill and to clean up the impacted area at lessee's own expense in compliance with applicable laws.
- E. Lessee shall be fully liable for all damages, costs and expenses related to a violation of the terms of the lease with respect to the use, storage, cleanup, remediation, or disposal of hazardous materials.

CITY OF HOMER
PROPERTY MANAGEMENT
POLICIES AND PROCEDURES

CHAPTER 17: PERFORMANCE STANDARDS

17.1 POLICY

It is the policy of the City of Homer that leased properties and the improvements on them shall be maintained in a way that provides for the health and safety of the community, and is consistent with community values with respect to zoning, aesthetics, architecture, and other values as determined by the City Council.

17.2 PROCEDURES

- A. All properties leased by the City are to be maintained in a proper, safe, clean, and orderly fashion taking into consideration its permitted use, surrounding, properties, zoning, and other applicable laws and regulations.
- B. The City of Homer reserves the right to enter leased property and the structures thereon at all reasonable times. This includes regular annual inspections.
- C. All commercial structures shall at all times be in compliance with applicable building, fire, mechanical, electrical and other regulations.
- D. Applicable building code and fire marshal inspections must be performed and certified to the City upon completion of all renovations, remodels, and / or new construction.
- E. Easements or Rights-of-Way on the leased parcel shall not be used in any way that interferes with the rights of the holders or any person(s) lawfully using the easement or right-of-way.
- F. Easements or Rights-of-Way outside of the leased parcel and/or immediately adjacent to it shall not be used for storage, parking, or any other authorized uses.
- G. Failure to comply with the performance standards listed in this section or any other provisions or stipulations contained in the lease are grounds for termination of the lease if the lessee does not rectify the problem after reasonable notice by the City.

CITY OF H
OMER
PROPERTY MANAGEMENT
POLICIES AND PROCEDURES

CHAPTER 18: CONCLUSION OF LEASE

18.1 POLICY

It is the policy of the City of Homer to provide for a smooth transition and the restoration of City property at the time a lease expires.

18.2 PROCEDURE

- A. Improvements constructed by the Lessee or sub-lessees shall be left in place unless removal is authorized or required by the provisions of the lease. If the lease authorizes or requires removal of improvements, they may be removed prior to the conclusion of the lease if doing so would not damage the leased property or adjoining properties. Removing improvements shall be coordinated with and approved by the City Manager prior to commencement of activities.
- B. Unless otherwise agreed by the parties, when the lessee is authorized or required to remove improvements, the lessee shall remove all improvements made on the property by lessee prior to termination of the lease.
- C. When authorized or required to remove improvements, if lessee fails to do so prior to the termination date of the lease, lessee shall forfeit the improvements to the City and shall receive no compensation therefore, or, at the City's election, pay to the City the costs incurred by the City in removing and disposing of the improvements.
- D. Unless otherwise provided in the lease, or agreed to in writing by the parties, the lessee shall restore the property to the same condition it was in at the time the lease was executed by the lessee.
- E. An environmental inspection (Phase I, plus further testing, including test holes if the need for such further testing is indicated by the Phase I inspection) shall be completed at the termination of the lease at the lessee's expense. Identified environmental problems shall be rectified by lessee at his/her expense.

**FISH PROCESSOR OUTFALL LINE
CONNECTION AGREEMENT**

The City of Homer, an Alaska municipal corporation, referred to as "CITY," and _____, referred to as "PROCESSOR," agree as follows:

1. Term. Subject to the terms, covenants, conditions, rights and obligations met forth in this Agreement, CITY agrees to provide, make and keep in repair a Fish Processor Outfall Line ("Outfall Line"), which consists of a pump station, an eight-inch diameter sewer line, and a diffuser at City's harbor facilities, and hereby grants PROCESSOR the right to discharge effluent to the Outfall Line. The term of this Agreement shall commence on _____ 201__ and end on _____ 20__.

2. Connection Charge. PROCESSOR shall pay to CITY the sum of SEVEN THOUSAND DOLLARS (\$7,000) as a connection charge for connecting PROCESSOR's service connection line to CITY's Outfall Line. PROCESSOR has the option to pay the connection charge in five equal annual installments of ONE THOUSAND FOUR HUNDRED DOLLARS (\$1,400), plus 7% interest. PROCESSOR will submit the first payment of the connection charge on _____, 201__ with yearly payments thereafter on that date.

3. Operation and Maintenance Charge. PROCESSOR shall pay to CITY an operation and maintenance charge (O & M charge") in advance on January 1st of each year, beginning in 201___. The annual O & M charge shall TWO THOUSAND FOUR HUNDRED DOLLARS (\$2,400) subject to adjustment by CITY. CITY shall give written notice to PROCESSOR of any adjustment in the O & M charge at least 30 days prior to January 1 of each year.

4. Default. CITY shall be entitled to terminate PROCESSOR's water service and use of the Outfall Line if PROCESSOR: (a) fails to pay any sums due under this Agreement for a period of ten (10) days from the due date; or (b) fails to keep any other term, covenant or condition of this Agreement for a period of fifteen (15) days after CITY provides PROCESSOR a written notice specifying the particular default or defaults; provided, however, that any default on the part of PROCESSOR shall be deemed to be cured if steps have been taken promptly to rectify the default (and in no event later than fifteen (15) days after such notice has been given), and prosecuted to completion with diligence.

5. Increasing or Decreasing Use of Outfall Line. If any additional parties connect to the Outfall Line or if PROCESSOR ceases to use the Outfall Line, PROCESSOR shall not be refunded or receive credit for previously paid connection charges, O & M charges or equipment replacement fund charges.

6. Payments. All payments due under this Agreement shall be payable at the office of the Finance Department, 491 East Pioneer Avenue, Homer, Alaska 99603-7624, or at such other place as CITY may designate in writing. Delinquent payments shall bear interest at the rate set forth in AS 45.45.010(a) as now enacted or hereafter amended. This Agreement incorporates by reference applicable terms of the City Credit Policy as now adopted or hereafter amended.

7. Discharge of Waste to Outfall Line. PROCESSOR shall install grinding apparatus to ensure that all waste discharged to the Outfall Line has a maximum particle size of one-quarter inch or less. PROCESSOR shall install screening apparatus to prevent the entry of foreign materials that could impede or damage the operation of the Outfall Line (e.g., rubber gloves, knives and rocks). PROCESSOR shall install flow control apparatus to ensure that discharge to the Outfall Line does not exceed maximum flow contribution. PROCESSOR's flow contribution is not to exceed 280 gallons per minute in any case.

8. Compliance With Laws. PROCESSOR shall comply with all applicable laws, ordinances and regulations or duly constituted public authorities now or hereafter in any manner affecting PROCESSOR's discharge to the Outfall Line. In particular, PROCESSOR shall comply with the City of Homer's National Pollutant Discharge Elimination System (NPDES) permit from the Environmental Protection Agency, shall pre-treat effluent to meet requirements imposed by the NPDES permit, and shall comply with all other permit requirements, including effluent reporting requirements. PROCESSOR shall provide CITY with a copy of all reports submitted to state or federal agencies in order to comply with reporting requirements regarding effluent imposed by the NPDES permit, state or federal laws. CITY will provide PROCESSOR with a copy of the NPDES General Permit and the City of Homer's Authorization to Discharge from EPA which PROCESSOR will have at their facility at all times.

9. Construction of Connection. PROCESSOR shall not commence construction of a service connection line to the Outfall Line unless the following events have occurred:

(a) PROCESSOR shall furnish to CITY proof that all applicable permits have been obtained, including a Sewer Connection Permit from CITY's Public Works Department.

(b) PROCESSOR shall furnish engineering plans, including plumbing diagrams, for PROCESSOR's service connection line to CITY's Public Works Department. The engineering plans shall demonstrate PROCESSOR's ability to grind fish waste, screen foreign materials and limit flow as required by this Agreement.

(c) PROCESSOR shall furnish to CITY proof that all necessary easements and rights-of-way for construction of a service connection line between PROCESSOR's facility and the Outfall Line pump station have been obtained.

10. Licensed and Bonded Contractor; Inspection of Construction. PROCESSOR shall use a licensed and bonded contractor to construct the service connection line. Prior to any discharge by PROCESSOR, CITY shall inspect the installation at the service connection at the pump station of the Outfall Line, and PROCESSOR's screening, grinding and flow control apparatus.

11. As-Built Drawings. Within 30 days after connection to the Outfall Line, PROCESSOR shall provide CITY with three (3) copies of as-built drawing of the service connection line drawn to scale and in a format acceptable to CITY.

12. RIGHT OF ENTRY. CITY, its agents, servants or employees, shall have the right to enter into and upon PROCESSOR's buildings or property at any time PROCESSOR is in operation for the purpose of inspecting whether PROCESSOR is in compliance with the terms of this Agreement. If PROCESSOR is not operating, CITY shall have the right to enter upon

reasonable notice to PROCESSOR and during normal business hours (9 a.m. to 5 p.m. Monday through Friday except for holidays).

13. Indemnity.

(a) PROCESSOR shall protect, indemnify and hold CITY harmless from and against any and all liability arising from acts or omissions of any person and of any nature whatsoever relating to PROCESSOR's service connection line or use of the Outfall Line causing injury to or death of persons, or loss of or damage to property, and from any expense, including attorney's fees, incident to the defense of and by CITY therefrom. If any action or proceeding is brought against CITY by reason of any such occurrences, CITY shall promptly notify PROCESSOR in writing of such action or proceeding.

(b) PROCESSOR shall protect, indemnify and hold harmless CITY and its authorized representatives, from and against any claims, demands, penalties, fines, judgment, loss, liabilities, settlements, damages, costs, or expenses (including, without limitation, attorney, consultant and expert fees, court costs and litigation expenses) of whatever kind or nature, known or unknown, contingent or otherwise, arising out of or in any way related to: (a) any violation by PROCESSOR of the NPDES permit, or local, state or federal regulation or law related to effluent discharge by PROCESSOR; (b) the presence, disposal, release, or threatened release of any Hazardous Material discharged by PROCESSOR to the sewer connection line or Outfall Line that is in, on, from, or affecting soil, water, vegetation, buildings, personal property, persons, animals or otherwise; (c) any personal injury (including wrongful death) or property damage (real or personal) arising out of or related to Hazardous Material discharged by PROCESSOR to the sewer connection line or Outfall Line; and/or (d) any lawsuit brought or threatened, settlement reached or government order relating to Hazardous Material discharged by PROCESSOR to the sewer connection line or Outfall Line. The provisions of this subparagraph (b) shall be in addition to any other obligations and liabilities PROCESSOR may have to CITY at law or equity and shall survive the termination of this Agreement.

For the purpose of this subparagraph (b), "Hazardous Material" is any substance that is toxic, ignitable, reactive, or corrosive and that is regulated by any local government, the State of Alaska, or the United States government. "Hazardous Material" included any and all material or substances that are defined as "hazardous waste", "extremely hazardous waste" or a "hazardous substance" pursuant to local, state, or federal law, including without limitation, the Resource Conservation and Recovery Act of 1976, as amended from time to time, and regulations promulgated thereunder, and the Comprehensive Environmental Response, Compensation and Liability Act of 1980, as amended from time to time, and regulations promulgated thereunder. "Hazardous Material" also included, but is not restricted to, asbestos, polychlorobiphenyls ("PCBs") and petroleum and petroleum products.

14. Damage to or Non-Operation of Outfall Line. PROCESSOR shall pay CITY for any damage to the Outfall Line resulting from PROCESSOR's discharge to or use of the Outfall Line. CITY shall not be liable to PROCESSOR for damages to PROCESSOR resulting from: (a) damage to the Outfall Line, whether caused by PROCESSOR or any other user of the Outfall Line; (b) non-operation of the Outfall Line due to maintenance; or (c) non-compliance with applicable laws by PROCESSOR or other users resulting in non-operation of the Outfall Line pursuant to an order issued by governmental agency or court.

15. Delivery of Notices - Method and Time. All notices, demands or requests from one party to another shall be delivered in person or be sent by mail, certified or registered, postage prepaid, to the address stated below and shall be deemed to have been given at the time of delivery or, if mailed, three (3) days after the date of mailing.

All notices, demands and requests from PROCESSOR to CITY shall be given to CITY at the following address:

City Manager
City of Homer
491 E. Pioneer Avenue
Homer, AK 99603
(907) 235-8121

All notices, demands and request from CITY TO PROCESSOR shall be given to PROCESSOR at the following address:

Telephone _____

IN WITNESS WHEREOF, the parties hereto have set their hands and seals the dates therein below set forth.

CITY OF HOMER

Date: _____

By: _____
City Manager

PROCESSOR

Date: _____

By: _____
Its:

State of Alaska)
) ss.
Third Judicial District)

THIS IS TO CERTIFY that on this _____ day of _____, 20____, before me, the undersigned Notary Public, personally appeared known to me to be the City Manager of the City of Homer, a municipal corporation organized and existing under the laws of the State of Alaska, and he/she acknowledged to me that he/she executed this Lease Agreement on behalf of said corporation for the uses and purposes therein set forth.

IN WITNESS WHEREOF I have hereunto set my hand and seal the day and year first hereinabove written.

Notary Public in and for Alaska
My Commission Expires:

State of Alaska)
) ss.
Third Judicial District)

THIS IS TO CERTIFY that on this _____ day of _____, 20____, before me, the undersigned Notary Public, personally appeared _____, known to me to be the _____ of _____, a corporation organized and existing under the laws of the State of _____, and he/she acknowledged to me that he/she executed this Lease Agreement on behalf of said corporation for the uses and purposes therein set forth.

IN WITNESS WHEREOF I have hereunto set my hand and seal the day and year first hereinabove written.

Notary Public in and for Alaska
My Commission Expires: