

Appendix F. Examples of Best Management Practices

Introduction

Appendix F is a discussion of the more commonly used erosion and sediment control practices. Objectives and applications are outlined for each practice. Use considerations, common failures, alternate measures, and relationship with other erosion and sediment control practices are described. Finally, design, materials, installation, inspection, maintenance, and removal are described for each measure. The measures described here are by no means all-inclusive. There are many variations to these practices according to site-specific conditions, and in addition there may be manufactured products available that will satisfy a particular need for erosion and sediment control. Table F-1 lists a matrix of uses for selected erosion control practices, and suggested symbology to be used on plans.

It is crucial to the success of erosion and sediment control at construction sites that individual measures be designed, constructed, and maintained with regard to the site, to other measures, and construction methods being used. Revegetation, either temporary or permanent, is integral to the process, and is discussed in detail in Section 16.8 of the *Alaska Highway Drainage Manual*.

**Table F-1
Matrix of Uses and Suggested Drawing Symbols**

Erosion and Sediment Control Measures	Pg.	Structural Measures		Stabilization (Erosion Control)	Temporary/ Permanent	Symbol
		Velocity Control	Sediment Control			
Interception/ Diversion Ditch	F-3	X			T, P	
Slope Drain	F-6	X			T	
Rock Flume	F-9	X			T, P	
Outlet Protection	F-11	X			T, P	
Stormwater Conveyance Channel	F-14	X			T, P	
Rock Check Dam	F-18	X			T, P	
Mulching	F-21			X	T	
Temporary Seeding	F-23			X	T	
Surface Roughening and Terracing	F-25			X	T	
Rolled Erosion Control Products	F-30			X	T, P	
Temporary Sediment Trap	F-34		X		T	
Vegetative Buffer Strip	F-37		X		T, P	
Silt Fence	F-40		X		T	
Inlet Protection	F-44		X		T	
Straw Bale Barrier	F-50		X		T	
Brush Barrier	F-53		X		T	
Vehicle Tracking Entrance/Exit	F-56		X		T	

1. Interception/Diversion Ditch

Objectives and Applications

An interception/diversion ditch, berm or excavated channel, or combination berm and channel constructed across a slope that functions to intercept runoff and divert it to a stabilized area where it can be safely discharged.

This measure should be used in construction areas where runoff can be diverted and disposed of properly to control erosion, sedimentation, or flood damage. Specific locations and conditions include above disturbed existing slopes, and above cut or fill slopes to prevent runoff over the slope; across unprotected slopes, as slope breaks, to reduce slope length; below slopes to divert excess runoff to stabilized outlets; where needed to divert sediment laden water to sediment traps; at or near the perimeter of the construction area to prevent sediment from leaving the site; above disturbed areas before stabilization to prevent erosion and maintain acceptable working conditions; around buildings or areas that are subject to damage from runoff, and during culvert installations where water must be temporarily diverted around the construction area. Diversions may be either temporary or permanent.

Common Failures - Generally due to faulty installation or maintenance.

- Berm not properly compacted during construction, resulting in uneven settling.
- Sediment accumulation against berm/channel not removed periodically, resulting in berm not functioning properly.

Other Considerations

- Berms to intercept and divert runoff should not be used where the drainage area exceeds 10 ac.
- Interception/diversion ditches should be carefully designed where longitudinal ditch slopes are steeper than 10 per cent.

Diversions are preferable to other types of man-made storm water conveyance systems because they more closely simulate natural flow patterns and characteristics, and flow velocities are generally kept to a minimum.

Relationship to Other ESC Measures

Diverted runoff should outlet to a stabilized area such as a sediment basin, detention or retention basin, or stabilized outlet, which should be established prior to introducing runoff from the diversion.

Alternate Sediment Control Measures

Slope Drain (can be used in association with this measure).

Other Names

Interceptor Ditch, Crown Ditch

Design

Location: *Should be determined by considering outlet conditions, topography, land use, soil type, and length of slope.*

Capacity: *permanent: 10 year peak runoff storm.
temporary: 2 year peak runoff storm.*

Berm

Berm Top Width: *minimum 2 ft.*

Berm Base Width: *minimum 4.5 ft.*

Berm Height: *minimum 18 in.*

Berm Side Slopes: *2:1 or flatter*

Ditch

Channel Freeboard: *minimum 6 in.*

Channel Side Slopes: *2:1 or flatter*

Materials

Compacted soil or coarse aggregate, riprap, filter fabric, plastic lining, seed and mulch, sandbags

Installation

Interception Ditch

Remove and properly dispose of all trees, brush, stumps, or other objectionable material. Fill and compact all ditches, swales, or gullies that that will be crossed to natural ground level. Excavate, shape, and stabilize the diversion to line, grade, and cross section as required in the plans. Compact the berm to prevent unequal settlement and to provide stability against seepage. Stabilize the diversion with vegetation after installation.

Diversions for Culvert Installations

Excavate the diversion channel to the specified dimensions, leaving temporary plugs at both ends. Place channel lining and stabilize with riprap or sandbags. Remove plugs at both ends (down-stream first) and divert water into the diversion with sandbags. After installation of the culvert is complete, replug the diversion, salvage the diversion lining, and backfill in the channel.

Inspection

Inspect the diversion every week and after each rainfall during construction operations.

Maintenance

Remove any sediment or other obstructions from the diversion channel. Check outlets and make repairs as necessary. Reseed areas that fail to establish a vegetative cover.

Removal

Temporary installations – Restore to existing or constructed grade. Seed and mulch.

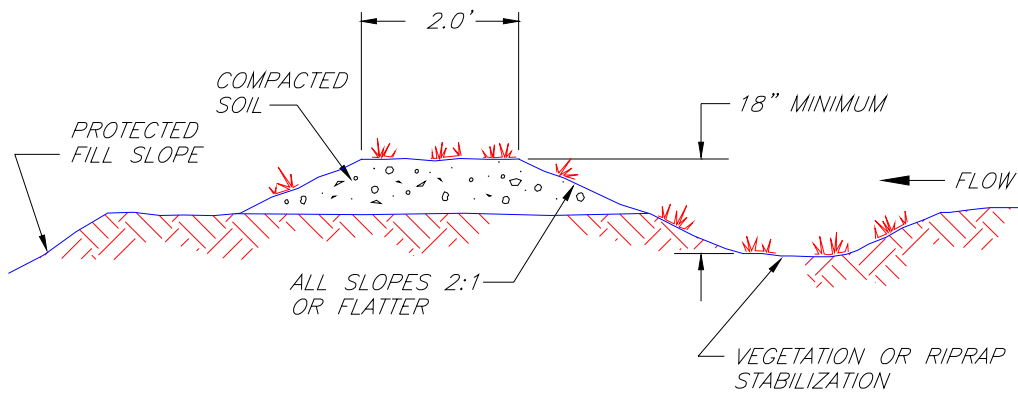

TYPICAL FILL DIVERSION

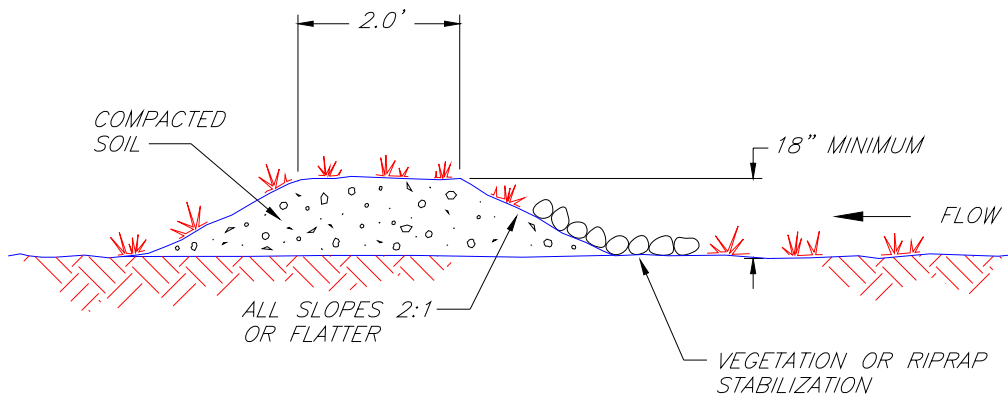

TYPICAL TEMPORARY DIVERSION DIKE

1996 JOHN McCULLAH

NOTES:

1. THE CHANNEL BEHIND THE DIKE SHALL HAVE POSITIVE GRADE TO A STABILIZED OUTLET.
2. THE DIKE SHALL BE ADEQUATELY COMPACTED TO PREVENT FAILURE.
3. THE DIKE SHALL BE STABILIZED WITH TEMPORARY OR PERMANENT SEEDING OR RIPRAP.



FILE: TEMPDIKE

INTERCEPTION/DIVERSION DITCH

2. Slope Drain

Objectives and Applications

A slope drain is a flexible tubing or conduit extending temporarily from the top to the bottom of a cut or fill slope.

The purpose of a slope drain is to temporarily conduct concentrated storm water runoff safely down the face of a cut or fill slope without causing erosion on or below the slope. These are temporary measures that are used during grading operations, until the permanent drainage structures are installed, and until the slopes are permanently stabilized. The pipe material is typically corrugated plastic or flexible tubing, and is used in conjunction with temporary diversion dikes along the top edge of newly constructed slopes, that function to direct storm water runoff into the slope drain.

Common Failures - Generally due to faulty installation or maintenance.

- Slope drain sections not securely fastened together; fittings not water tight, resulting in leakage.
- Slope drain sections not securely anchored to the slope, resulting in displacement of the structure.
- Materials placed on, or construction traffic across slope drain, resulting in damage to the structure.

Other Considerations

- Provide both inlet and outlet protection to minimize erosion at these locations.
- Slope drains should be used in conjunction with diversion dikes to convey runoff from the drainage area.
- The entrance section must be securely entrenched, all connections must be watertight, and the conduit must be securely staked.

Relationship to Other ESC Measures

Slope drains are used with temporary diversion dikes to facilitate channeling of runoff into the structure. Inlet and outlet protection are required to minimize erosion and scour.

Alternate Sediment Control Measures

Diversion

Other Names

Downdrain; Drop Pipe

Design

Design life: 1 season (6 months) or less

Contributing flow drainage area: should not exceed 5 acres per slope drain. If contributing drainage area exceeds this amount, consider using a more permanent installation such as a rock-lined flume, etc.

Capacity: 2 year peak runoff or the design discharge of the water conveyance structure, whichever is greater

Slope drain size (minimum)	
Drainage area (Acres)	Pipe diameter (Inches)
0.5 ac.	12 in.
1.5 ac.	18 in.
3.5 ac.	24 in.
5.0 ac.	30 in.

Flexible conduit: heavy duty flexible material, such as corrugated plastic pipe or plastic tubing

Inlet section: standard flared end section for metal pipe culverts, or geotextile, for inlet protection

Diversion dike height: minimum 12 in. higher than the top of the drain pipe

Island over inlet height: minimum 18 in. higher than the top of the drain pipe

Outlet section: riprap or geotextile, for outlet protection

Materials

Flexible corrugated plastic pipe or specially designed plastic tubing; grommets or stakes (for fastening); riprap, geotextile

Installation

Place slope drains on undisturbed ground or well-compacted fill at locations specified on the plans. Place the entrance of the drain in a 6 in. sump at the top of the slope. Hand tamp the soil under and around the entrance in 6 in. lifts. Ensure that fill over the top of the drain has minimum dimensions of 18 in. height, 4 ft. top width, and 3:1 side slopes. Install inlet protection using end section for pipes or geotextile. Use watertight fittings at all slope drain connections. Securely fasten the exposed section of the pipe with grommets or stakes at 10 ft. spacings. Extend the drain beyond the toe of the slope and provide riprap or geotextile outlet protection. Construct the diversion dike 12 in. above the top of the pipe entrance. Compact and stabilize the dike.

Inspection

Inspect slope drains weekly and immediately after each rainfall that produces runoff for erosion around the inlet and outlet that could result in undercutting or bypassing. Inspect the pipe for breaks or clogs.

Maintenance

Immediately repair any erosion around the inlet or outlet; install a headwall, riprap, or sandbags if necessary. Promptly repair any breaks in the pipe and clear any clogs that reduce flow through the structure.

Removal

After the slope has been permanently stabilized and the permanent drainage system has been installed, remove the slope drains and stabilize the remaining disturbed areas.

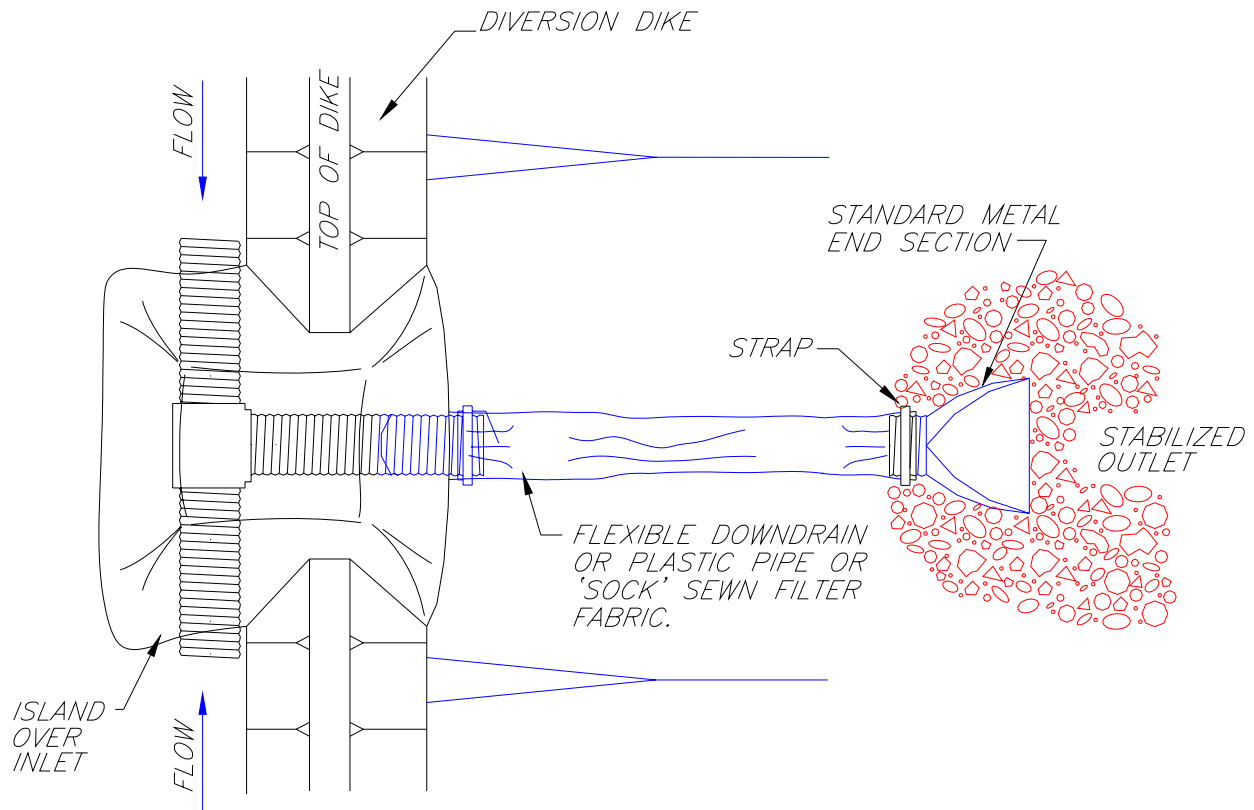

PLAN VIEW

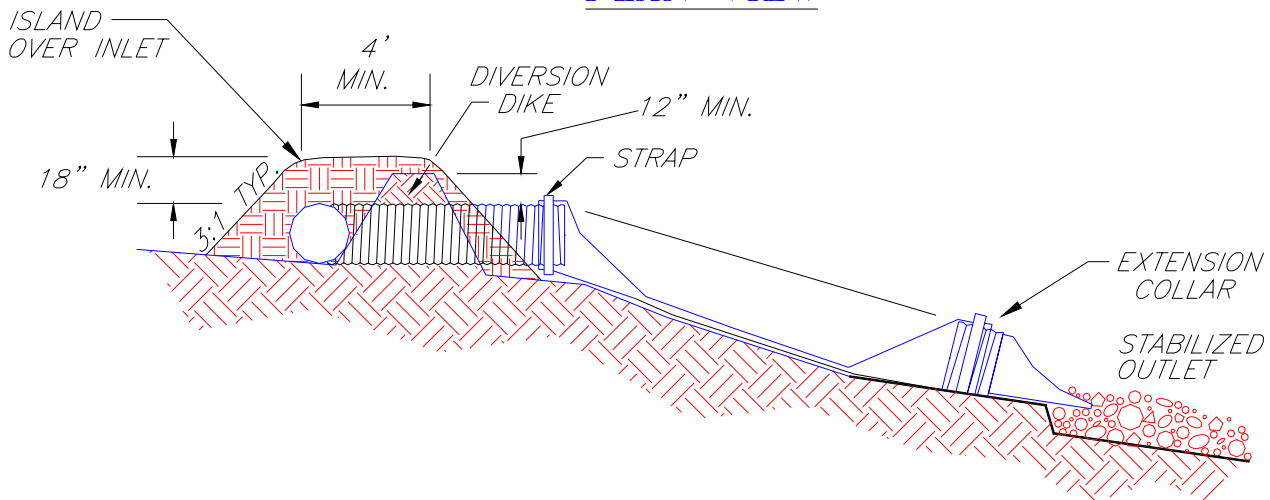

SECTION

SLOPE DRAIN

3. **Rock Flume**

Objectives and Applications

A rock flume is a riprap-lined channel to convey water down a relatively steep slope without causing erosion problems on or below the slope.

Flumes serve as stable, permanent elements of a storm water system receiving drainage from above a relatively steep slope, typically conveyed by diversions, channels, or natural drainageways. Drainage will flow down the rock culvert and into a stabilized outlet, sediment trap, or other conveyance measure.

Common Failures - Generally due to faulty installation or maintenance.

- Stone size too small or backslope too steep, resulting in stone displacement.
- Sediment accumulation in flume channel, resulting in reduced capacity.
- Channel width too narrow, resulting in over topping and erosion.

Other Considerations

- Provide both inlet and outlet protection to minimize erosion at these locations.
- Rock flumes should be used in conjunction with diversion dikes to convey runoff from the drainage area.
- When planning rock flumes, consider flow entrance conditions, soil stability, outlet energy dissipation, and downstream stability.

Relationship to Other ESC Measures

Rock flumes assist in the second, conveyance, stage of a BMP system. Rock flumes are used with diversion dikes to facilitate channeling of runoff into the structure

Alternate Sediment Control Measures

Storm water conveyance channel

Other Names

Rock chute, rock downdrain

Design

Contributing flow drainage area: *not to exceed 10 acres per rock flume.*

Capacity: *10 year peak runoff or the design discharge of the water conveyance structure, whichever is greater.*

Flume Channel Lining	
Drainage Area (Acres)	Riprap Sizes (Class)
5.0 ac	Class I
10.0 ac	Class II

Slope: *not to exceed 1.5:1 (67 %)*

Depth: *minimum 1 ft.*

Alignment: *straight*

Inlet section: *riprap and geotextile, or flared metal end section for inlet protection*

Outlet section: *riprap and geotextile, for outlet protection*

Materials

Riprap, geotextile, flared metal end section

Installation

Remove all unsuitable material, such as trees, brush, roots, or other obstructions prior to installation. Shape the channel to proper grade and cross-section as shown in the plans, with no abrupt deviations from design grade or horizontal alignment. Compact all fills to prevent unequal settlement. Place geotextile prior to placement of riprap.

Inspection

Inspect flume channels at regular intervals as well as after major rains for sediment accumulation, material displacement, bank failures, and scour at inlet and outlet sections.

Maintenance

Rock flume channels should be checked periodically to ensure that scouring is not occurring beneath the fabric underlying the riprap layer, or that the stones have not been displaced by the flow. Sediment should be removed from the riprap lined channel if it reduces the capacity of the channel.

Removal

Rock flumes will normally be left in place after construction is completed.

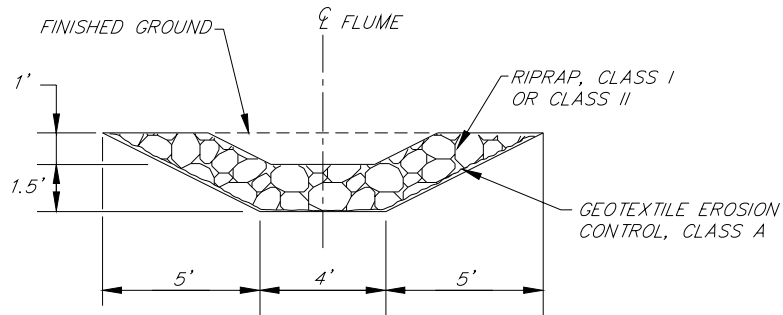
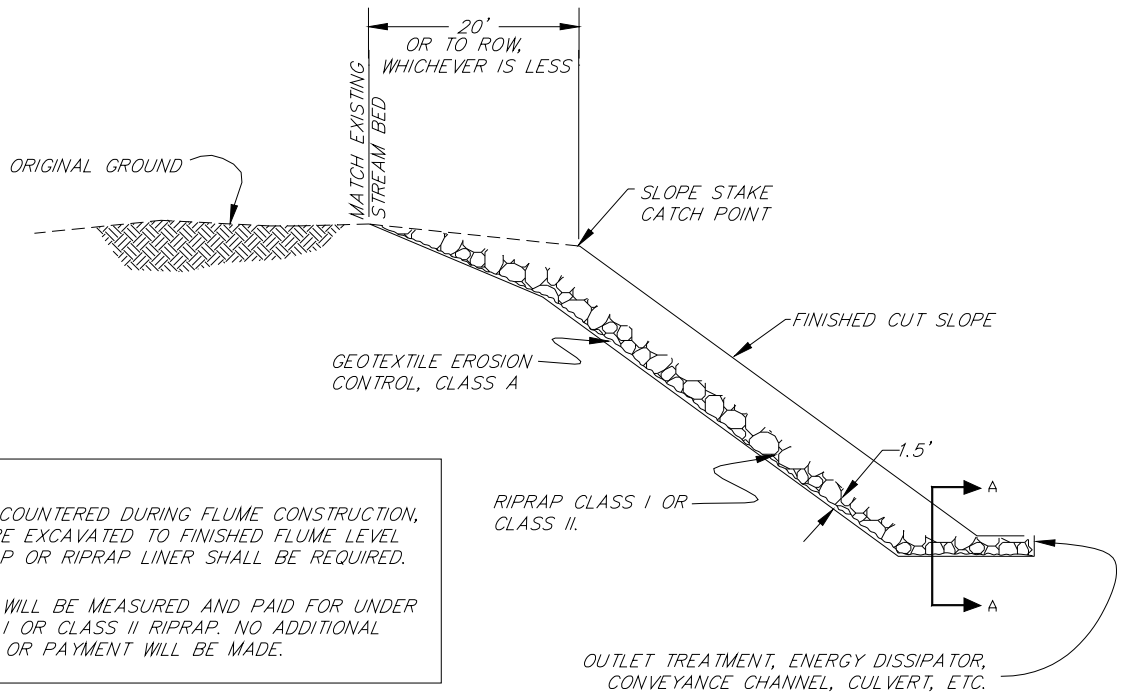

SECTION A-A

ROCK FLUME DETAIL

Rock Flume

4. Outlet Protection

Objectives and Applications

An outlet protection is a structure designed to control erosion at the outlet of a pipe by reducing flow velocity and dissipating flow energy.

This measure should be used where the discharge velocity of a pipe exceeds the tolerances of the receiving channel or disposal area. To prevent scour and undermining, an outlet protection structure is needed to absorb the impact of the flow and reduce the velocity to non-erosive levels. A riprap lined apron is the most commonly used practice for this purpose because of its low cost and ease of installation. Designs will vary based on discharge specifics and receiving stream conditions. Outlet Protection may be temporary or permanent.

Common Failures - Generally due to faulty design, installation or maintenance.

- Inadequate apron length, resulting in scouring
- Riprap rock that is too small for runoff velocities

Other Considerations

- The riprap apron should be extended downstream until stable conditions are reached even though this may exceed the length calculated for design velocity control
- If the pipe discharges into a well defined channel, the side slopes of the channel shall not be steeper than 1:2 (horizontal:vertical)
- Riprap stilling basins or plunge pools should be considered in lieu of aprons where pipe outlets are perched or where high flows would require excessive apron length. Design guidelines for stilling basins can be found in Hydraulic Design of Energy Dissipators for Culverts and Channels, Hydraulic Engineering Circular No. 14, USDOT, FHWA (1983).

Relationship to Other ESC Measures

Outlet protection may be installed at the discharge points of grassed waterways or swales, storm water conveyance channels, sediment basins, and wet ponds.

Alternate Sediment Control Measures

Other structural energy dissipators, such as riprap stilling basins, baffle wall basins or T-fitting on the end of corrugated metal pipe.

Other Names

Stabilized Outlet.

Design

Capacity: *2 year peak runoff or the design discharge of the water conveyance structure, whichever is greater. Determine the maximum allowable velocity for the receiving stream, and design the riprap apron to reduce the flow to this velocity*

Apron Length: *The apron length shall be six times the diameter of the outlet pipe.*

Apron Width: *The apron width shall be four times the diameter of the outlet pipe.*

Materials: *The apron should be lined with riprap. The riprap should consist of a well-graded mixture of stone, with larger stones predominating. The diameter of the largest stone shall be no greater than the 1.5 times the median stone size. Geotextile filter cloth shall be placed between the riprap and the underlying soil.*

Grade: *The apron shall be less than or equal to the receiving channel grade, preferably a flat (0%) slope. Steeper grades may require alternative measures such as riprap stilling basins, or other energy dissipators.*

Alignment: *The apron shall be straight throughout the entire length.*

Additional Design Guidelines: *Hydraulic Design of Energy Dissipators for Culverts and Channels, Hydraulic Engineering Circular No. 14, USDOT.*

Materials

Rock riprap; geotextile filter cloth.

Installation

Ensure that the subgrade for the filter and riprap follows the required lines and grades shown in the plan.

Compact any fill required in the subgrade to the density of the surrounding undisturbed material. The riprap must conform to the specified grading limits shown on the plan. Filter cloth must meet the design requirements and be properly protected from punching or tearing during installation.

Riprap may be placed by equipment, but take care not to damage the filter cloth. Ensure that the riprap consists of a well-graded mixture of stones. The diameter of the largest stone should be no greater than 1.5 times the median stone size. The minimum thickness of the riprap apron should be 1.5 times the maximum stone diameter. Riprap may be field stone or rough quarry stone, and should be hard, angular, weather resistant, and well graded. Make the top of the riprap at the downstream end level with the receiving area or slightly below it. Ensure that the apron is properly aligned with the receiving stream and preferably straight throughout its length. If a curve is needed to fit site conditions, place it in the upper section of the apron. Stabilize all disturbed areas with vegetation immediately after construction.

Inspection

Inspect outlet protection weekly and after heavy rains to look for erosion around or below the riprap, dislodged stones, and scouring. Outlet protection should also be monitored for sediment accumulation filling the voids between rocks.

Maintenance

Make immediate repairs if any conditions noted under inspection are found. Sediment should be removed when it fills the voids between rocks.

Removal

Restore ground to existing or constructed grade. Revegetated measures may be left in place only if specifications specifically allow it.

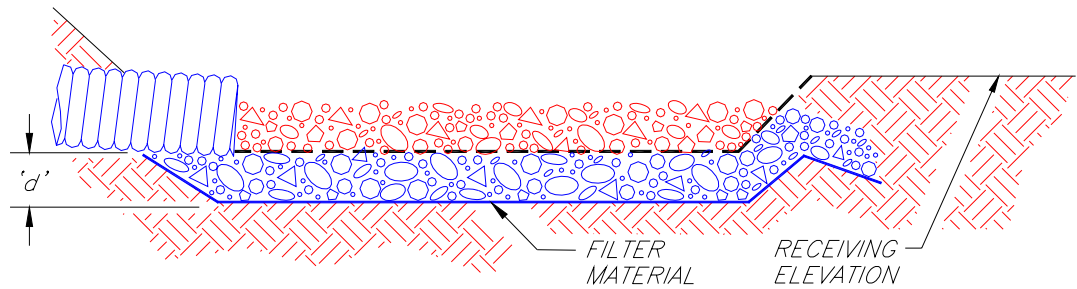

THICKNESS ('d') = 1.5 x MAX. ROCK DIAMETER - 6" MIN.

SECTION

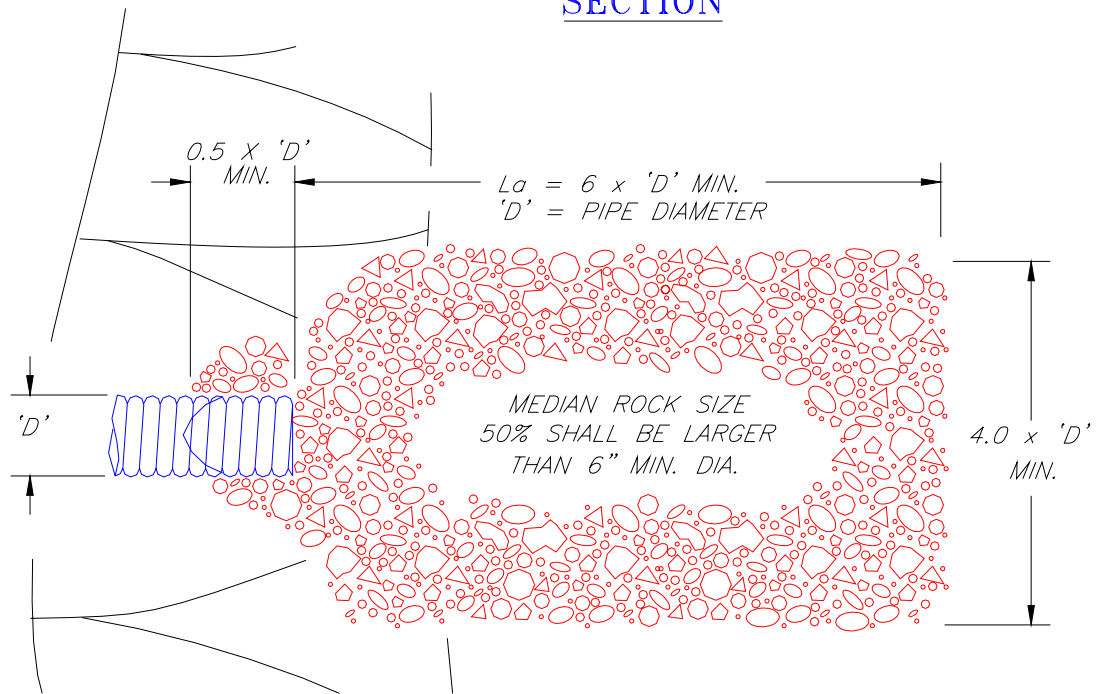

PLAN

NOTES:

1. 'La' = LENGTH OF APRON. DISTANCE 'La' SHALL BE OF SUFFICIENT LENGTH TO DISSIPATE ENERGY.
2. FILTER MATERIAL SHALL BE FILTER FABRIC OR 6" THICK MINIMUM GRADED GRAVEL LAYER.

© 1994 JOHN McCULLAH

FILE: ENRGYDIS

OUTLET PROTECTION

5. Storm Water Conveyance Channel

Objectives and Applications

A storm water conveyance is a channel lined with vegetation, riprap, or other flexible material designed for the conveyance and safe disposal of concentrated surface runoff to a receiving system without damage from erosion.

The main design considerations are the volume and velocity of the water expected in the channel. All conveyance channels should be designed to carry at least the appropriate peak flow. Other factors to be considered include availability of land, aesthetics, safety, maintenance requirements, and soil characteristics. There are two types of cross sections for channel linings, trapezoidal and triangular (“V” shaped). All channels should discharge through a stabilized outlet that should be designed to handle the expected runoff velocities and volumes from the channel without resulting in scouring.

Channel linings function to protect drainage channels against erosion through the use of flexible linings (vegetation, riprap, gravel, or flexible, porous mats), and may be used as either a temporary or a permanent sediment control measure. The selection of a type of lining should be based upon the design flow velocities.

Common Failures - Generally due to faulty maintenance.

- Sediment accumulation – channel capacity is reduced, resulting in over topping and erosion
- Failure of lining

Other Considerations

- Channels should be located to conform with and use the natural drainage system.
- Grass lined channels should not be subject to sedimentation from disturbed areas.
- Grass-lined channels may be unsuitable if channel slopes over 5% predominate, continuous or prolonged flows occur, potential exists for damage from traffic (people or vehicles), or soils are erodible.
- Channel side slopes should be 2:1 or flatter in the case of rock-riprap lining. Vegetated channel side slopes should be 4:1 or flatter.

- When using riprap as a liner, a geotextile filter blanket or one or more layers of granular filter should be placed before placing the riprap. The thickness and gradation of the granular filter, or specifications for the geotextile, should be included in the plans.
- Vegetation in grass lined channels should be established before flows are introduced.

Relationship to Other ESC Measures

All channels should discharge through a stabilized outlet. The outlet should be designed so that it will handle the expected runoff velocities and volumes without scouring. An energy dissipator may be needed if flow velocities exceed the allowable velocity of the receiving channel.

Alternate Sediment Control Measures

Grass Lined Swale

Other Names

Channel Stabilization

Design

The following information is needed to design channel linings.

- *Expected runoff peak flow*
Temporary: 2-year frequency storm
Permanent: 10-year frequency storm
- *Desired channel capacity*
- *Slope of the channel*
- *The type of cross-sectional design of channel*
- *The type of lining*
- *Design depth or design cross sectional area*

Design Guidelines – *Design procedures should be consistent with steps outlined in chapter 8.6.3.1 of the Alaska Highway Drainage Manual. Basic steps will include:*

1. *Establish a roadside plan*
2. *Obtain or establish cross section data*
3. *Determine initial channel grades*
4. *Check flow capacities and adjust as necessary*
5. *Determine channel lining/protection needed (following procedures in FHWA Hydraulic Engineering Circular No. 15, “Design of Roadside Channels with Flexible Linings”)*
6. *Analyze outlet points and downstream effects*

Materials

Filter blanket or geotextiles, flexible, porous mats (fiberglass, plastic, or jute), staples, riprap, gravel, seed, fertilizer, mulch.

Installation

Remove all unsuitable material, such as trees, brush, roots, or other obstructions prior to installation. Shape the channel to proper grade and cross-section as shown in the plans, with no abrupt deviations from design grade or horizontal alignment. Compact all fills to prevent unequal settlement. Remove any excess soil and dispose of properly.

Grass lined channels – Seed, fertilize and mulch.

Riprap lined channels – Place a geotextile filter blanket or a granular filter, prior to placement of riprap.

Mat lined Channels –Seed and fertilize. Apply the matting from the upper end of the channel and continue downgrade. Secure the top end of the matting by excavating a 6 in. trench, followed by back-filling and compacting. Overlap rolls of matting at least 6 in.. Excavate a 6 in. x 6 in. trench every 35 ft. and inset a fold of the mat into the trench. Staple securely on 6 in. centers, using minimum 6 in. long staples, then backfill and compact. Roll channel lining with a heavy roller after seeding, mat placement, and stapling are complete.

Inspection

Inspect channels weekly as well as after major rains for sediment accumulation, material displacement, bank failures, and scour at inlet and outlet sections.

Maintenance

Grass Lined Channels – During the initial establishment, grass lined channels should be repaired immediately and grass re-established if necessary. After grass has become established, the channel should be checked periodically to determine if the grass is withstanding the flow velocities without damage. The channel should be repaired if scour is found to be present, and any debris or sediment accumulation should be removed.

Riprap Lined Channels – Riprap lined channels should be checked periodically to ensure that scouring is not occurring beneath the fabric underlying the riprap layer, or that the stones have not been displaced by the flow. Sediment should be removed from the riprap lined channel if it reduces the capacity of the channel.

Mat Lined Channels – Inspect channel linings following each major storm or snowmelt event and repair as necessary. If the desired grass has not become established through a mat, replace the matting, taking care not to disturb any areas of established grass.

Removal

Temporary channels - Provide and compact fill to existing or constructed grade. Seed and mulch.

FREEBOARD HEIGHT (H), CHANNEL GEOMETRICS AND STONE SIZE SHALL BE DETERMINED BY THE ENGINEER

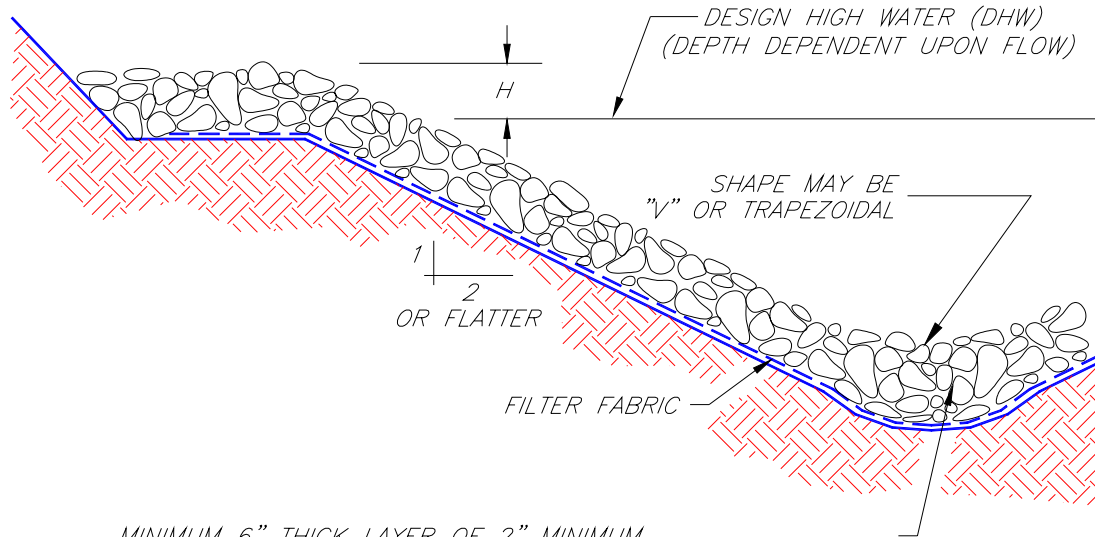

MINIMUM 6" THICK LAYER OF 2" MINIMUM DIAMETER DRAIN ROCK. LARGER STONE AND THICKNESSES SHALL BE USED DEPENDENT UPON GRADIENT, SOIL TYPE, AND DESIGN FLOW.

TYPICAL SECTION

1994 JOHN McCULLAH



FILE: RCKCHNEL

STORM WATER CONVEYANCE CHANNEL, RIPRAP

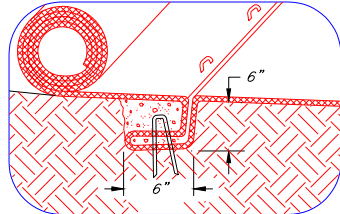
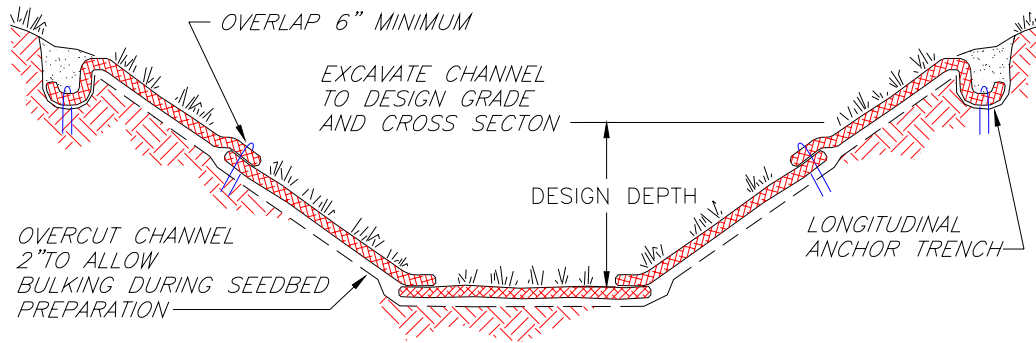

INTERMITTENT CHECK SLOT

TYPICAL INSTALLATION WITH EROSION CONTROL BLANKETS OR TURF REINFORCEMENT MATS

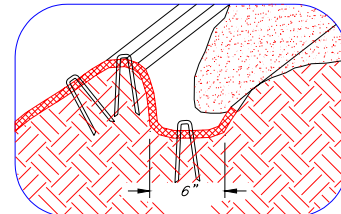

LONGITUDINAL ANCHOR TRENCH

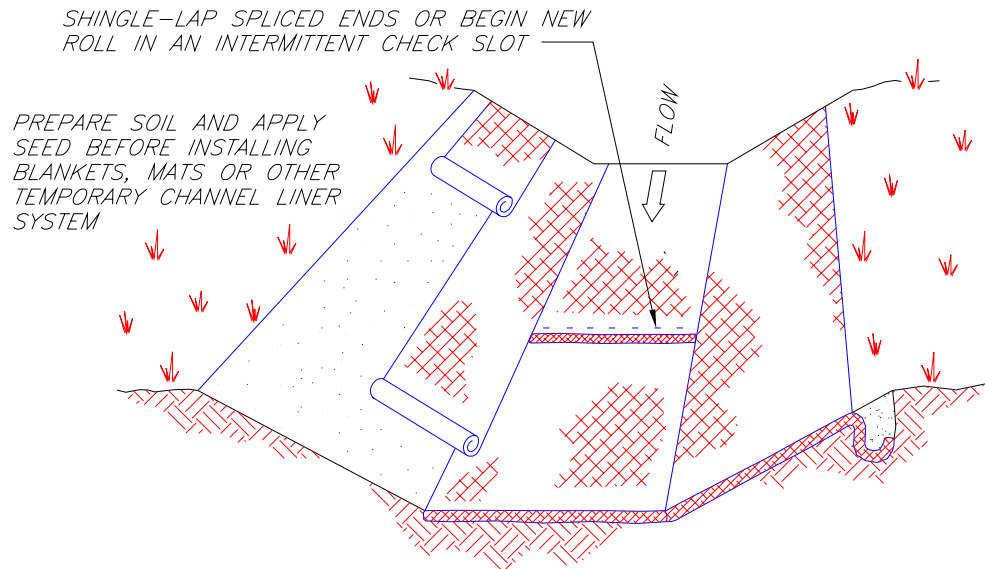

NOTES:
 1. DESIGN VELOCITIES EXCEEDING 2.0 FT/SEC REQUIRE TEMPORARY BLANKETS, MATS OR SIMILAR LINERS TO PROTECT SEED AND SOIL UNTIL VEGETATION BECOMES ESTABLISHED.
 2. GRASS-LINED CHANNELS WITH DESIGN VELOCITIES EXCEEDING 6.0 FT/SEC SHOULD INCLUDE TURF REINFORCEMENT MATS.

NOT TO SCALE

© 1996 JOHN McCULLAH

FILE: GRSSINST

STORM WATER CONVEYANCE CHANNEL, MAT

6. Rock Check Dam

Objectives and Applications

A rock check dam is an expedient (or emergency) temporary measure to protect narrow erosion-susceptible waterways and/or reduce the sediment loads in channeled flows. Check dams may also be used as permanent measures.

Temporary check dams are placed in series in ditches, swales, gullies, or other minor drainageways intended to be filled or stabilized at a later time. They are used to slow stormwater velocities and direct scouring flows away from channel surfaces. The dam configuration supports sediment settling from silted waters pooled behind the weir. Small sediment particles become lodged in the dam's interior.

Permanent check dams may be used as gradient control structures in ditches adjacent to elevated roadway sections.

Common Failures - Check dams are vulnerable to failure from concentrated flow.

- Undercut/washout of channel banks beside the structure due to improper installation (e.g. dam not built high enough onto the banks).
- Increased bank erosion (e.g. at channel bends) or inadequate protection of channel surfaces due to improper location or installation of check dams.
- Water backup and bank overflow due to overly tall dam structure.
- Rocks washed downstream may clog culverts, misdirect flow, etc.
- Check dams installed in grass lined structures may kill the vegetative lining if siltation is excessive or the dam remains submerged for extended periods of time.

Other Considerations

- Coupling check dams with adjacent upstream sumps facilitates sediment removal.
- Rock check dams are used in narrow ditches and gullies. Straw bales are used primarily in wide swales.

- Rock check dams may be more costly to install than straw bale check dams.
- Check dam rocks interfere with the establishment of vegetation.
- Rock check dams left as permanent structures interfere with grass mowing (maintenance).
- Steep channel slopes reduce effectiveness.
- Coupling check dams with a small adjacent upstream sump improves velocity slowing and sediment trapping ability.
- The area downstream from the last dam should be stabilized or flow diverted.

Relationship to Other ESC Measures

As part of the perimeter control ESC network, check dams are used for channel protection prior to establishment of permanent or stabilized erosion controls. Although check dams do some sediment filtering, they are not intended to replace filters or sediment basins. A depression in the bottom of the channel at the upstream edge of a check dam augments velocity slowing and sediment removal. Digging a sump through stabilized in-channel protection (e.g. grassed lining) should be avoided, however. Check dams interfere with localized vegetative channel protection. Rocks prohibit establishment of in-situ vegetation and the protective lining is subject to disturbance/ destruction during check dam removal.

Alternate Sediment Control Measures

- Drainage diversion during channel stabilization.
- Protective channel linings (e.g. grassed waterway, concrete or rock-lined ditch, erosion control blankets or mattings), straw bales, sediment settling ponds, permanent ditch blocks, sand bag check dams, brush barriers or combinations or these measures.

Other Names

In Stream/Channel Energy Dissipator

Design

The design of rock check dams (high at channel banks, lower in the middle) directs overtopping flows centrally to avert scouring of channel surfaces. The dam is keyed into channel slopes to prevent bank undercut and erosion.

Spacing between dams is based on waterway grade, height of adjacent check dams and desired length of backwater effect. The distance shown in the table below has been calculated for the protection of channel banks between successive structures. Placement of check dams at abrupt bends should be avoided since erosive waters could be misdirected by the check dam into channel banks.

Check dam structures are sized to stay in place during peak flow and should pass 2-year storm runoff without overtopping the roadway or ditch side-slopes. Generally, dams are not constructed higher than recommended as follows since excessive weir depth seriously impacts the flow characteristics of the ditch.

The following dimensions may be modified for site-specific applications:

Standard Check Dam

Maximum drainage area: *not to exceed 10 acres*

Normal flow velocity: *no greater than 6 ft/sec.*

Maximum height at dam center: *not greater than 2 ft. or one half the channel depth*

Minimum height difference between center and (bank) sides: *6 in.*

Structure slope: *1:2*

Maximum spacing between standard (2 ft. high) check dams: *align top of check dam level with toe elevation of the upstream dam*

Channel Slope (%)				
2	3	4	5	6
Spacing (ft.)				
100	67	50	40	33

Materials

Clean hard angular (e.g. crushed, shot) rock graded according to expected flows. Two- to three-inch stone is usually adequate.

Alternate materials: logs, brush and twigs, sandbags partially filled with pea gravel. Use only clean materials. Avoid introduction of fines.

Installation

Install dams as soon as drainage routes are established. Place rock by hand or mechanical means, distributing smaller rocks to the upstream side to prevent transport. Check structures key into a trench that spans the complete width of the channel. Extend dams high onto the channel banks (above anticipated high water level) to prevent localized undermining and erosion. In unlined channels, a small sump dug at the upstream side of the dam facilitates sediment collection and removal.

Inspection

Observe dam function during/after each rainfall event that produces runoff and note conditions of channel surfaces. Visually compare upstream and downstream flows to determine relative turbidity levels and effectiveness of velocity checks. Inspect channel banks for evidence of undermining and erosion. Look for dam deterioration and for migration of structural components downstream. Observe level of sediment buildup behind dam. It should not exceed ½ dam height. Observe ESC effectiveness during flows to determine if adjunct measures are needed. The dam should be stable and appropriately sized to withstand high velocity events.

Maintenance

Repair check dam voids and bank undercuts. Fortify disintegrating dams and install additional dams or other ESC measures as needed. Correct undesirable effects of rock migration (e.g. clogged culvert, flow construction). Periodically remove sediment deposits.

Removal

Care should be taken since the waterway surfaces are susceptible to damage during check dam removal. Damaged or unprotected areas should be seeded immediately or other forms of protection provided as warranted. Some check dams are left as a permanent control measure. Removal may be indicated because of unsightliness or interference with maintenance activities.

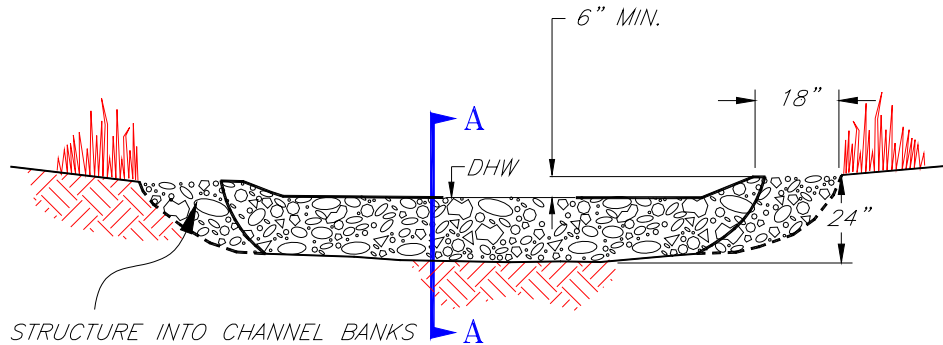

KEY STRUCTURE INTO CHANNEL BANKS
AND EXTEND IT BEYOND THE ABUTMENTS
A MINIMUM OF 18" TO PREVENT
FLOW AROUND DAM.

VIEW LOOKING UPSTREAM

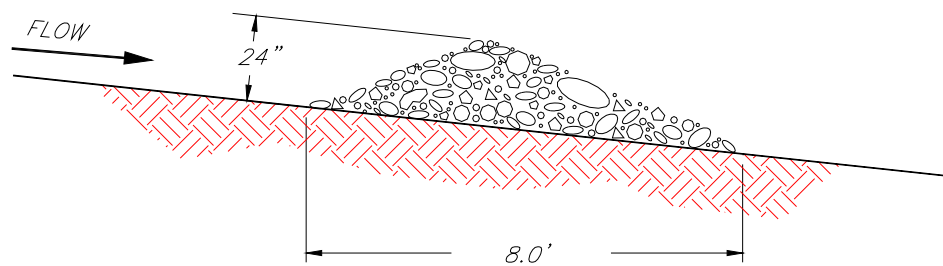

SECTION A - A

'L' = THE DISTANCE SUCH THAT POINTS 'A' AND
'B' ARE OF EQUAL ELEVATION.

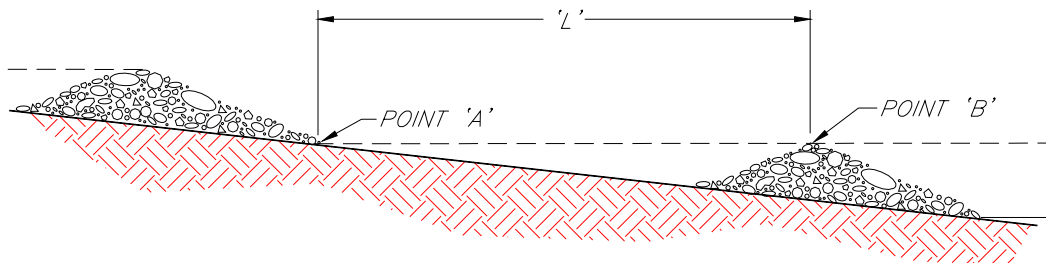

SPACING BETWEEN CHECK DAMS

NOT TO SCALE

1994 JOHN McCULLAH



FILE: RCKCHKDM

ROCK CHECK DAM

7. **Mulching**

Objectives and Applications

Mulching is the application of a uniform protective layer of straw, wood fiber, wood chips, or other acceptable material on or incorporated into the soil surface of a seeded area to allow for the immediate protection of the seed bed.

The purpose of mulching is to protect the soil surface from the forces of raindrop impact and overland flow, foster the growth of vegetation, increase infiltration, reduce evaporation, insulate the soil, and suppress weed growth. Mulching also helps hold fertilizer, seed, and topsoil in place in the presence of wind, rain, and runoff, and reduces the need for watering. Mulching may be utilized in areas that have been seeded either for temporary or permanent cover.

There are two basic types of mulches, organic mulches and chemical mulches. Organic mulches include straw, hay, wood fiber, paper fiber, wood/paper fiber blends, peat moss, wood chips, bark chips, shredded bark, manure, compost and corn stalks. This type of mulch is usually spread by hand or by machine (mulch blower) after seed, water, and fertilizer have been applied. Chemical mulches, also known as soil binders or tackifiers, are composed of a variety of synthetic materials, including emulsions or dispersions of vinyl compounds, rubber, asphalt, or plastics mixed with water. Chemical mulches are usually mixed with organic mulches as a tacking agent to aid in the stabilization process, and are not used as a mulch alone, except in cases where temporary dust and erosion control is required. Hydroseeding, sometimes referred to as hydromulching, consists of mixing a tackifier, specified organic mulch, seed, water, and fertilizer together in a hydrosurry and spraying a layer of the mixture onto a surface or slope with hydraulic application equipment. The choice of materials for mulching should be based on soil conditions, season, type of vegetation, and the size of the area.

Common Failures - Generally due to faulty installation or maintenance.

- Mulches are not properly watered after application, resulting in drying out and possible blowing or washing away of materials.
- Depth of mulching material is either insufficient or excessive, resulting in low seed germination rates.

- Hydroseeding slurry not applied uniformly, resulting in spotty germination and inadequate ground cover.

Other Considerations

- Mulch should be applied immediately after seeding to improve seed germination.
- Hydroseeding can be performed in one step, and is effective provided that materials are properly mixed and equipment is in good working order.
- Depth of the applied mulch should be not less than 1 in. and not more than 2 in.
- Chemical soil stabilizers or soil binders, when used alone, are less effective than other types of mulches. These products are primarily useful for tacking organic mulches.
- A tackifier should be used in conjunction with seeding, fertilizing, and mulching or hydro-seeding on any slopes steeper than 3:1.
- Check labels on chemical mulches and binders for environmental concerns. Take precautions to avoid damage to fish, wildlife, and water resources.
- Some materials such as wood chips may absorb nutrients necessary for plant growth.

Relationship to Other ESC Measures

Mulching may be performed in conjunction with seeding, fertilizing, surface roughening, and grading practices. Concentrated flows of runoff should be directed away from mulched areas.

Alternate Sediment Control Measures

Erosion Control Blankets; Sodding

Other Names

Hydromulching; Chemical Stabilization

Design

Design life: 1 season (6 months) or less

Site applicability: Areas which have been disturbed and require temporary or permanent cover

Materials and application rates: *as per Section 619 and Section 727 of Alaska Standard Specifications for Highway Construction, and Special Provisions for project*

Materials

Most Commonly Specified Mulches – Wood Fiber, Paper Fiber, Wood/Paper Fiber Combination Blends, Peat Moss

Other Mulches – Straw, Hay, Wood Chips, Bark Chips, Shredded Bark, Corn Stalks, Compost, Manure

Tackifiers – Vinyl Compounds, Rubber, Asphalt, or Plastics mixed with water

Installation

Complete the required grading as shown on the plans and ensure that erosion control measures intended to minimize runoff over the area to be mulched are in place. Apply mulch at the rates specified in the special provisions either by hand or by machinery immediately after the seed and fertilizer have been applied (two step method), or as part of the hydroslurry incorporating seed, fertilizer, mulch, and water (one step method). Apply specified tackifier if not already incorporated into the mulch matrix or hydroslurry. Provide additional watering as specified to ensure optimal seed germination conditions.

Inspection

Inspect all mulches weekly, and after each rainstorm to check for rill erosion, dislocation, or failure.

Maintenance

Replace mulch that has been loosened or dislodged. In addition, reseed areas if necessary. Water mulched areas periodically to ensure that moisture content will be maintained and seed germination and grass growth will continue.

Removal

Mulching is usually left in place to naturally decompose and become part of the soil structure.

8. Temporary Seeding

Objectives and Applications

To establish a temporary vegetative cover on disturbed areas by seeding with appropriate and rapid growing annual grasses, usually annual ryegrass.

The purpose of temporary seeding is to stabilize the soil and reduce damage from wind and/or water until permanent stabilization is accomplished. Seeding is applicable to areas that are exposed and subject to erosion for more than 30 days, and is usually accompanied by surface preparation, fertilizer, and mulch. Temporary seeding may be accomplished by hand or mechanical methods, or by hydraulic application (hydroseeding), which incorporates seed, water, fertilizer, and mulch into a homogeneous mixture (slurry) that is sprayed onto the soil.

Common Failures - Generally due to faulty installation or maintenance.

- Seed is not properly watered after application, resulting in drying out and low germination rates.
- Depth of mulching material is either insufficient or excessive, resulting in low seed germination rates.
- Hydroseeding slurry is not applied uniformly, resulting in spotty germination and inadequate ground cover.

Other Considerations

- Proper seedbed preparation and the use of high quality seed are essential to the success of this practice.
- Temporary seeding should take place as soon as practicable after the last ground-disturbing activities in an area.
- Once seeded, protect the area from foot and equipment traffic.
- Temporary seeding is not recommended if permanent seeding will be completed in the same growing season. Other temporary stabilization measures should be considered.

Relationship to Other ESC Measures

Seeding should be performed in conjunction with mulching, fertilizing, surface roughening, and grading practices. Concentrated flows of runoff should be directed away from seeded areas using diversions.

Alternate Sediment Control Measures

Erosion Control Matting, Plastic Sheetting

Other Names

Temporary Stabilization

Design

Seed Selection: *Annual Ryegrass (Lolium multiflorum)*

Seed Application Rate: *60 lbs/acre (average rate, site specific conditions may require more or less)*

Fertilizer Application Rate: *600 lbs/acre 20-20-10 (nitrogen-phosphorous-potassium [average rate, site specific conditions may require more or less])*

Materials

Seed, water, fertilizer, mulch

Installation

Grade as needed where it's feasible to permit the use of equipment for seedbed preparation. Prepare the seedbed by using surface roughening if soil has been compacted by machinery or heavy foot traffic. If using hand or mechanical methods, apply fertilizer in order to optimize growing conditions, followed by seed, mulch, and water. If using hydroseeding, mix seed, mulch, fertilizer, and water as per the manufacturer's recommendations. Apply slurry as per the manufacturer's recommendations.

Inspection

Inspect newly seeded areas on a regular basis and after each storm event to check for areas where protective measures (mulch) have failed or where plant growth is not proceeding at the desired rate.

Maintenance

Water seeded areas daily until initial ground cover is established if rainfall does not provide moisture for seed germination. Reseed areas where growth is absent or inadequate. Provide additional fertilizer if needed.

Removal

Removal of temporary vegetation is usually not necessary. Continue inspections and remedial action until the site is stabilized by permanent vegetation.

9. Surface Roughening and Terracing

Objectives and Applications

Surface roughening and terracing includes establishing a rough soil surface by creating horizontal grooves, furrows, depressions, steps, or terraces running parallel to the slope contour over the entire face of the slope.

These measures are intended to aid in the establishment of vegetative cover from seed, to reduce runoff velocity and increase infiltration, and to reduce erosion and provide for sediment trapping. They provide simple, inexpensive and immediate short-term erosion control for bare soil where vegetative cover is not yet established. A rough, loose soil surface gives a mulching effect that provides more favorable moisture conditions than hard, smooth surfaces and that aids in seed germination. The measure chosen to achieve these goals depends on the grade of the slope, the type of slope (cut or fill), soil and rock characteristics, future mowing and maintenance requirements, and type of equipment available. The most common measures utilized include:

Tracking – This is done by running machinery (such as bulldozers) up and down slopes to leave horizontal depressions in the soil, and is generally limited to sandy soils in order to avoid undue compaction of the soil surface.

Groove Cutting – This is done by cutting serrations along the contour with a blade attached to a dozer or other equipment.

Contour Furrows – This is done by cutting furrows (a series of ridges and depressions) along the contour of a slope, and is applicable to any area that will safely accommodate disks, tillers, spring harrow, or the teeth of a front end loader.

Stair Step Grading – This is done by cutting “steps” along the contour of a slope, and is applicable to slopes with a gradient greater than 3:1 which have material soft enough to be bulldozed and which will not be mowed.

Gradient Terracing – This is done by constructing earth embankments or ridges and channels along the face of a slope at regular intervals to intercept

surface runoff and conduct it to a stable outlet. This measure is applicable to long, steep slopes where water erosion is a problem, and should not be constructed in areas with sandy or rocky soils.

Common Failures - Generally due to faulty installation or maintenance.

- Roughening washed away by heavy rain, necessitating reroughening and reseeded.
- Failure of upslope control measures (diversions), resulting in excessive flows over area and erosion of soil.

Other Considerations

- These measures are of limited effectiveness in anything more than a moderate storm.
- These measures may not be suitable for noncohesive or highly erodible soils.
- All fills should be compacted to reduce erosion, slippage, settlement, subsidence, and other related problems.
- The finished cut and fill slopes to be vegetated should not exceed 2:1.
- Use slope breaks, such as diversions, benches, or contour furrows to reduce the length of cut and fill slopes to limit sheet and rill erosion.

Relationship to Other ESC Measures

Diversions at the upper perimeter of the area function to prevent runoff from causing erosion on the exposed soil. Silt fences and sediment basins at the lower perimeter of the area function to prevent off site sedimentation.

Alternate Sediment Control Measures

Erosion Control Blankets

Other Names

Contour Grading, Serration

Design

Measure Applicability: *Construction slopes greater than 5 vertical feet.*

Measure Selection: *Should be determined by slope grade, soil type, mowing requirements, and slope type (cut or fill).*

Materials

Construction equipment (bulldozer, front end loader, crawler tractor).

Installation

Cut Slope Roughening (Areas Not To Be Mowed)

Stair step grade or groove cut slopes that are steeper than 3:1. Use stair step grading on any erodible material soft enough to be ripped with a bulldozer. Slopes consisting of soft rock with some subsoil are particularly suited to stair step grading. Make the vertical cut distance less than the horizontal distance, and slightly slope the horizontal position of the “step” in toward the vertical wall. Do not make individual vertical cuts more than 2 ft. high in soft materials or more than 3 ft. high in rocky materials. Groove the slope using machinery to create a series of ridges and depressions that run across the slope, on the contour.

Fill Slope Roughening (Areas Not To Be Mowed)

For slopes greater than 3:1, ensure that the face of the slope consists of loose, uncompacted fill 4 in. – 8 in. deep. Use contour furrows or tracking to roughen the face of the slope, if necessary. Do not blade or scrape the final slope face.

Cuts, Fills, And Graded Areas (To Be Mowed)

Make mowed slopes no steeper than 3:1. Roughen these areas with shallow grooves by using tilling, disking, or harrowing implements. Make grooves close together, less than 12 in., and not less than 1 in. deep. Avoid excessive roughness on areas to be mowed.

Roughening With Tracked Machinery

Limit roughening with tracked machinery to sandy soils in order to avoid undue compaction of the soil surface. Operate machinery up and down the slope to leave horizontal depressions in the soil. Do not back blade during the final grading operation.

Inspection

Inspect the areas every week and after each rainfall that produces runoff during construction operations.

Maintenance

Seed, fertilize, and mulch areas which are graded as quickly as possible. Regrade and reseed immediately if rills appear.

Removal

Surface roughening and gradient terracing will remain an integral part of the slope after final stabilization with vegetation.

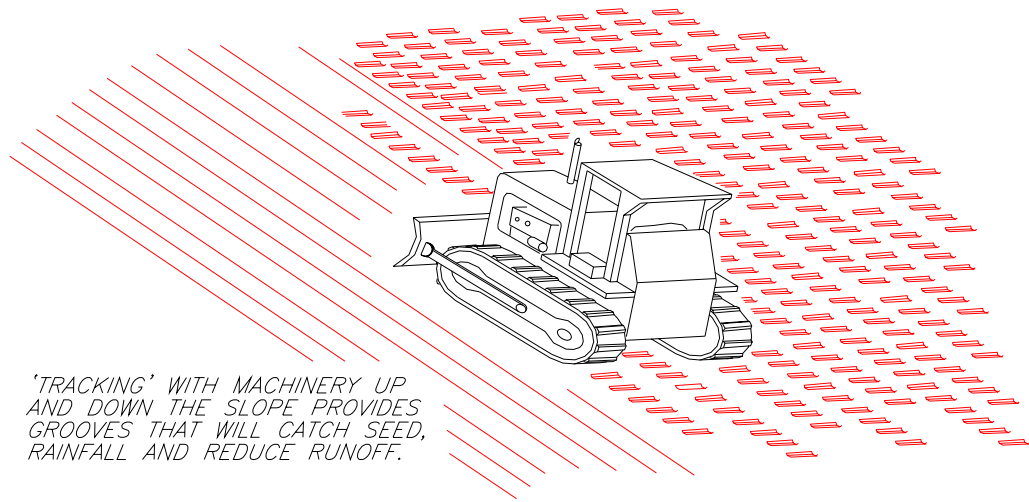

TRACKING

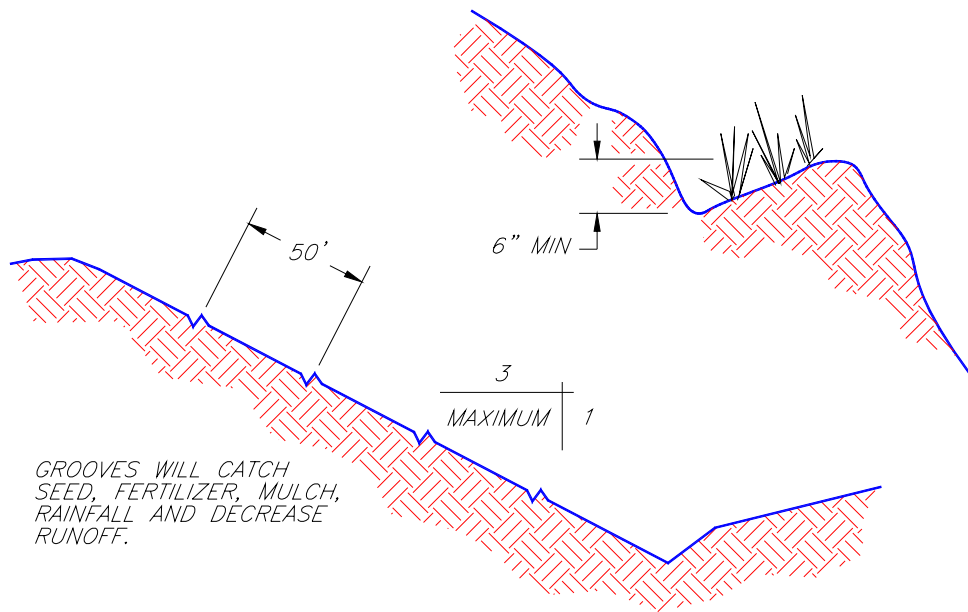

CONTOUR FURROWS

1994 JOHN McCULLAH



FILE: SRFROUGH

SURFACE ROUGHENING AND TERRACING

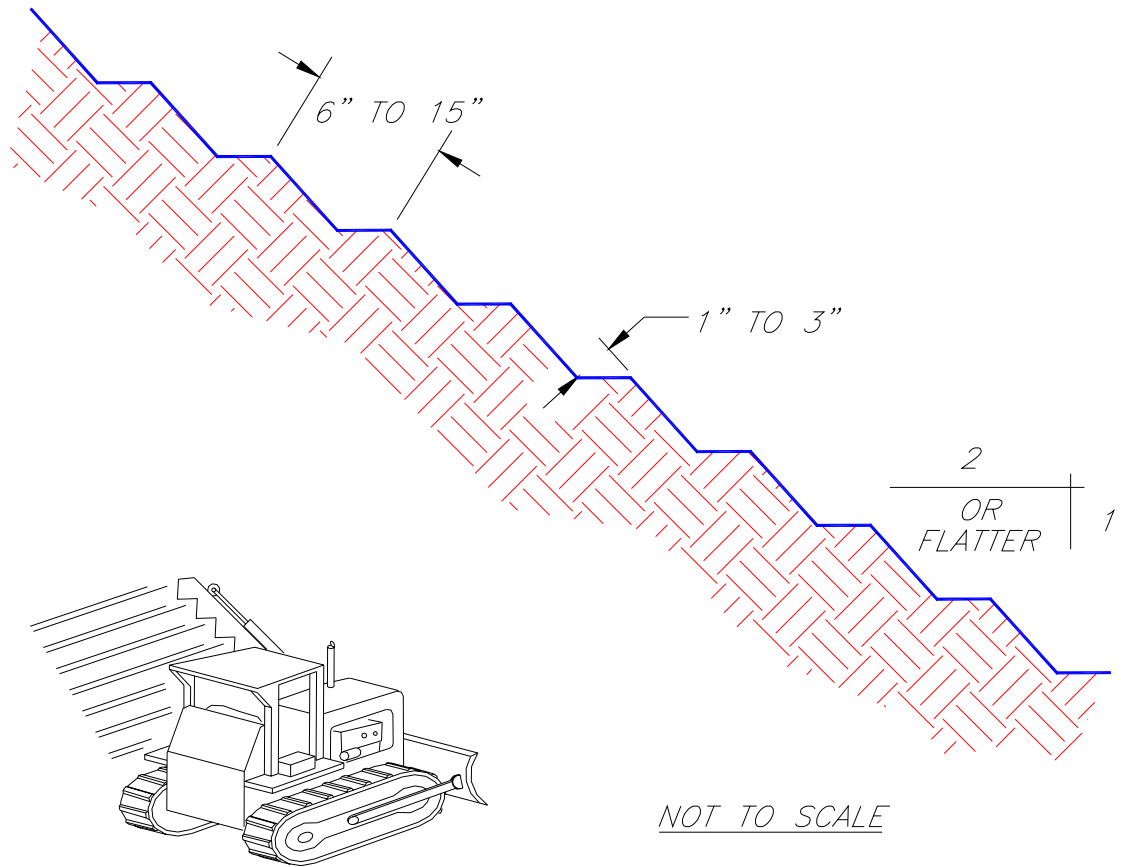

1994 JOHN McCULLAH

NOTE:

GROOVE BY CUTTING SERRATIONS ALONG THE CONTOUR. IRREGULARITIES IN THE SOIL SURFACE CATCH RAINWATER, SEED, MULCH AND FERTILIZER.



FILE: SERSLOPE

SURFACE ROUGHENING AND TERRACING

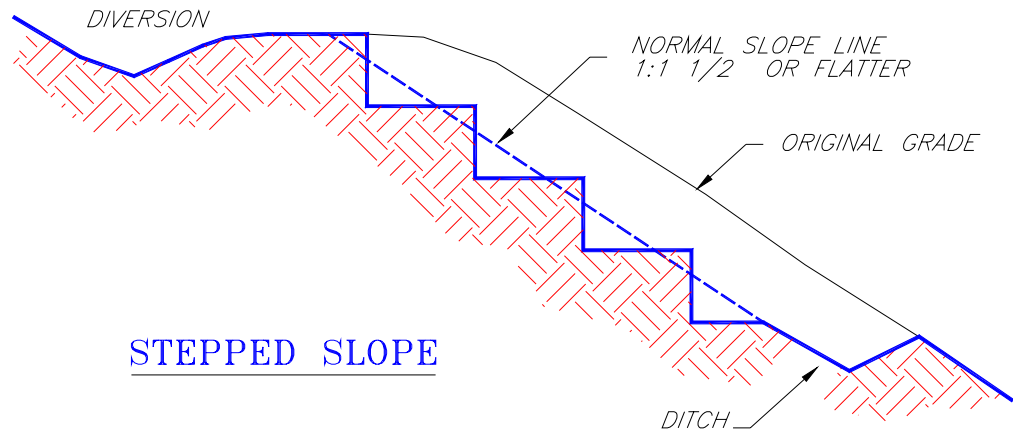

STEPPED SLOPE

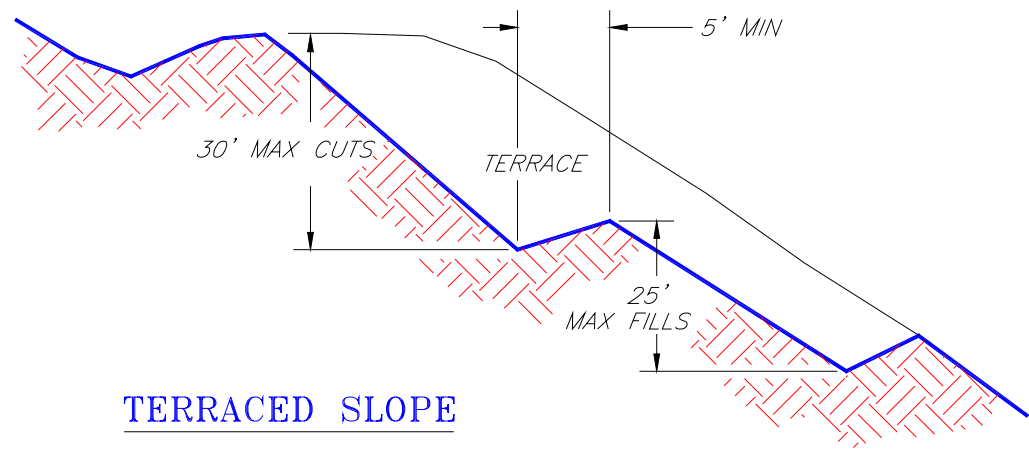

TERRACED SLOPE

NOT TO SCALE

- NOTES:
1. VERTICAL CUT DISTANCE SHALL BE LESS THAN HORIZONTAL DISTANCE.
 2. VERTICAL CUT SHALL NOT EXCEED 2 FT IN SOFT MATERIAL AND 3 FT IN ROCKY MATERIAL.

© 1994 JOHN McCULLAH

FILE: STPSLOPE

SURFACE ROUGHENING AND TERRACING

10. Rolled Erosion Control Products

Objectives and Applications

Rolled erosion control products (RECPs) are manufactured long sheets or coverings that can be unrolled onto unvegetated cut or fill slopes where erosion control or soil stabilization is needed. They are used where temporary seeding and mulching alone are inadequate, or where mulch must be anchored and other methods such as crimping or tackifying are unfeasible. There are many types of RECPs—and an ever-changing array of new products and manufacturers' claims. Applications range from coverings for temporarily inactive construction sites to long term protection of steep slopes.

Common RECP categories include:

Temporary RECP *designed for short term use--e.g. up to 1 year.*

Degradable (generally preferred and more prevalent) *made from naturally decomposing materials.* Different fibers yield different characteristics and breakdown patterns. RECPs are either:
photodegradable—broken down by sunlight exposure or
biodegradable—deteriorated by action of biological organisms.

Erosion control blanket(ECB): matrix of long-fibered mulch held by netting on one or both sides or sewn though the filler. Common ECB mulches are straw, wood shavings (excelsior), flax, coconut fiber (coir) and jute.

Jute matting: woven jute fiber mesh.

Netting: fixative mesh cover to keep mulch in place. Made of cotton, jute, coir or photodegradable plastics. Opening sizes vary by design purpose.

Non-degradable *does not decompose with exposure to the elements*

Plastic sheeting: occasionally used for urgent, short-term protective treatment or for overwintering disturbed slopes.

Semi-permanent RECP *lasts 4-8 years--commonly made from coir products*

Permanent RECP *does not decompose for 10 years or more*

Synthetic Turf Protection Mat: mechanically, structurally or chemically bound continuous mesh of processed or polymeric fibers. Mats are thick, heavy, long lasting. Some are designed to structurally support vegetation.

Common Failures - Generally due to faulty installation or maintenance.

- Seed washout/soil erosion due to water flow beneath poorly secured RECPs.
- Failed/inhibited growth of vegetative cover.
- Unintended RECP destruction by equipment, the elements, wildlife etc.

Other Considerations

- Expensive RECPs aren't necessarily more effective than lower cost RECPs.
- Installation requirements, surface features & preparation, installer experience.
- RECP features; suitability constraints, strength, durability, degradation rate.
- Vegetation viability practices including: soil, temperature, insulation and sunlight requirements for plant species; site suitability including topsoil adequacy; fertilizer/growth-enhancer needs; moisture and timing requirements for germination and plant growth; over-saturation; destructive moisture levels cause seed/plant mold/mildew/rot.
- RECP seasonal durability; e.g. overwintering plastic sheeting tears.
- Ease of RECP puncture (desirable for bio-remedial shoot penetrations).
- Slope length and steepness relative to vegetative support & blanket saturation, weight and durability.

- Runoff velocities, volumes, moisture infiltration rates.
- Compatibility and interaction with other on-site erosion measures. E.g. plastic netting and mattings don't retain moisture or heat useful for germination enhancement; plan means to disperse snow accumulations or high runoff volumes at the toe of plastic covered slopes.
- Visual impact, including public's perception of erosion protection needs and available levels/sophistication of erosion technologies.
- Compatibility with land use (e.g. urban or well-populated sites).
- Interactions with wildlife: habitat, susceptibility to foraging, grazing, nesting

Relationship To Other ESC Measures

RECPs can complement seeding and revegetation. Byproducts of RECP decomposition add mulch benefits and soil enhancement. RECPs can be used in conjunction with benching or other runoff velocity slowing or redirecting measures. RECPs aid dust control.

Alternate Sediment Control Measures

Stabilization measures for vegetation preservation. Crimped, tracked or tackified mulches. Benching, terracing, diversions or other means to reduce slope steepness, length and runoff velocity and volume.

Other Names

Terms used interchangeably: e.g. matting, blanket, sheet. Specified names e.g. Erosion Control Geotextile, ECB, Straw blanket, Mulch Mat

Design

Consult product distributors for recommendations regarding RECP selection and performance criteria suitable for site-specific parameters. Evaluate:

- *Duration of need--Temporary (e.g. 2 mo., 6 mo., 1 yr.) vs. Permanent (2-10 yrs.)*
- *Slope length*
- *Slope gradient (e.g. less than 1:1, 2:1, 3:1 or steeper)*

- *Soil type & erodibility*
- *Seasonal temperature & weather patterns; regional precipitation distribution*
- *Vegetation needs, especially where germination conditions are not optimal*

Blankets: on grades > 2:1 are subject to high stresses.

Synthetic turf protection mat: distribute loads across (saturated) fill slopes and reinforce root systems. Use where slope protection is needed at least 2 years. Use on highly erodible slopes (>3:1), for steep slide rehabilitation, for heavy/high velocity runoff, landfill or high elevation reclamations, drought areas, long cut/fill slopes, bridge abutments etc.

Plastic sheeting: 6 mil or thicker. Not recommended as cover for seeded slopes.

Wood fiber mat: drawbacks: bulky, difficult to place, 10–20% less effective erosion control than other mat types. May need to replace soil nitrogens leached by degrading wood.

Netting: Plastic netting doesn't hold heat or moisture, may require increased thickness of netted straw mulch 25%. Plastic netting and wood fiber mulches alone should not be used where runoff water flow exceeds 7 ft./sec.

Jute matting: Apply alone for seed germination enhancement or dust control, but not where runoff is significant.

Materials

Matting: Burlap, Jute Mesh Fabric, Woven Paper or Sisal Mesh Netting, Knitted Straw Mat, Woven/ Curled Wood Blanket.

Anchors: U-shaped wire staples, triangular wooden stakes, willow stakes.

Staples: U-shaped steel wire (normally 8 in. long, 1 in. wide, 11 gage or heavier, a 12-in. length, 9 gage or heavier).

Installation

RECPs -Excavate a 6" X 6" check slot trench at a level area well behind the slope crest or slopetop berm. Backfill and tamp over RECP roll end, leaving no gaps to allow under-blanket runoff invasion. Unroll sheeting downslope, parallel to grade and runoff path. Midslope splicings overlap successive sheets in the direction of flow so that upslope ends extend past the trench 16" anchoring the next downslope section. Stagger adjacent splicings. Anchor RECP terminal ends in slope toe key trenches and repeat the entire process until the entire slope has continuous coverage.

Lay RECPs to follow ground contours closely but do not stretch taut across surface depressions. Staple RECPs to maintain firm contact with underlying surfaces. Staple patterns vary depending upon slope length, grade, soil type and runoff rates. Staple blanket perimeters at no less than 12 in. intervals across the top and 3 ft. spacings along RECP sides and bottom. Staple intervals should be sufficient to prevent runoff flows beneath the blanket. Staple through 5 in. adjacent overlaps strips and staple every 3 ft. down sheet centerlines. Adjacent staple lines should stagger.

Plastic Sheeting - Anchor in slopetop trench (as above) to seal from runoff flow beneath sheeting. Duct tape 18 in. overlap seams to seal against wind and rain. Cover the entire exposed area. Hold sheets close to slope by suspending weights (tires, sandbags etc.) from ropes affixed to uphill anchors set no more than 10 ft. apart. Secure so wind doesn't lift the cover, expose slopes or tear plastic.

Inspection

Check that surfaces adhere, fasteners remain secure and covering is in tight contact with soil surface beneath. Look for damaged areas and exposed soil surfaces. Pay special attention to seams and uphill edges.

Maintenance

Repair, re-anchor, reinstall or replace matting. Re-seed where needed. It is especially important to protect overwintering plastic covered slopes, since the saturated soils may be easily erodible upon thaw.

Removal

Non-degradable RECPS must be removed manually when no longer useful and disposed at an offsite landfill or by other approved methods. Degradable RECPs naturally deteriorate over time and can add soil enrichment.

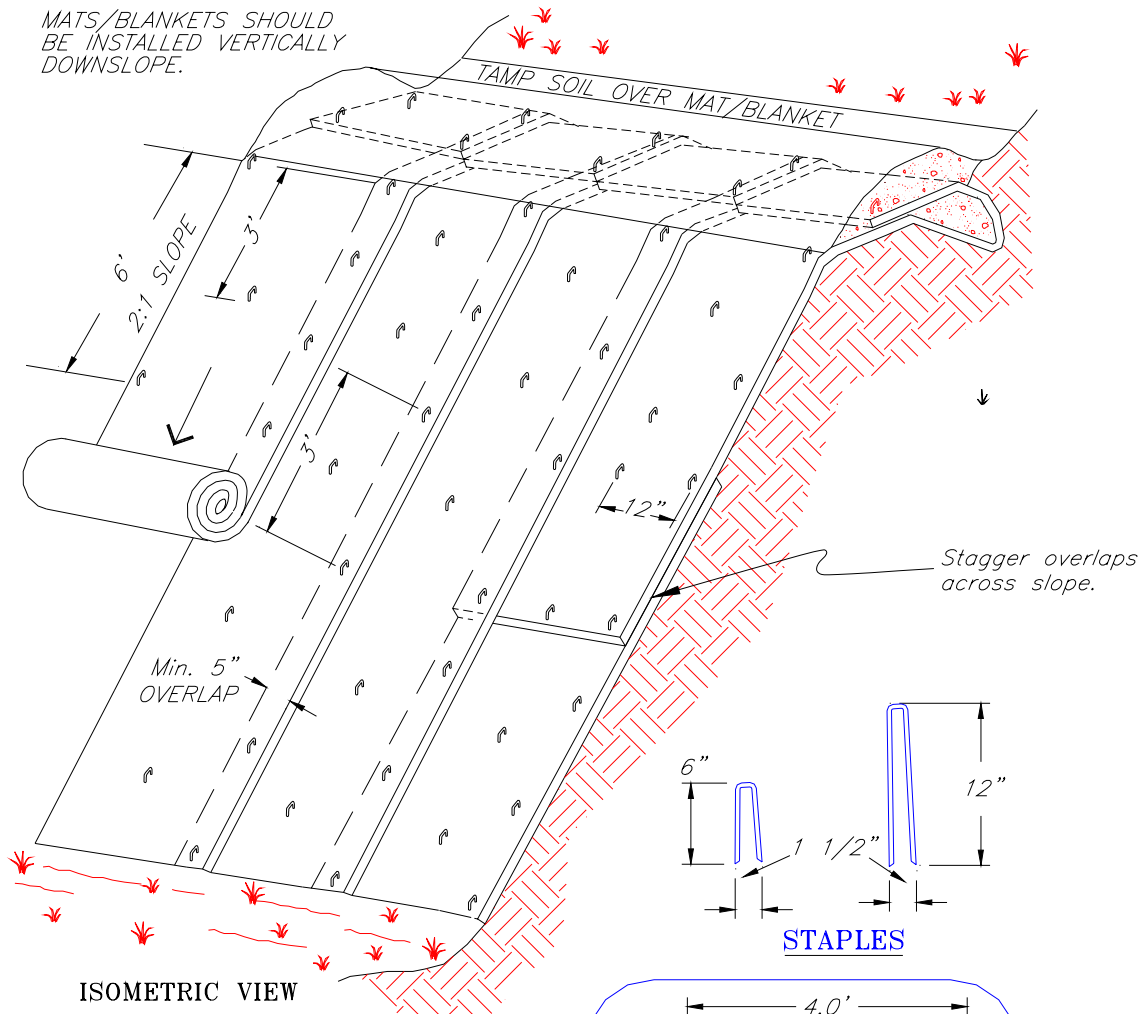

**TYPICAL SLOPE
SOIL STABILIZATION**

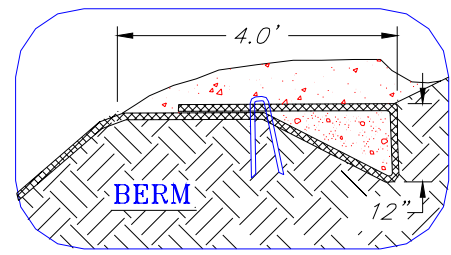

NOT TO SCALE

- NOTES:
1. SLOPE SURFACE SHALL BE FREE OF ROCKS, CLODS, STICKS AND GRASS. MATS/BLANKETS SHALL HAVE GOOD SOIL CONTACT.
 2. APPLY PERMANENT SEEDING BEFORE PLACING BLANKETS.
 3. LAY BLANKETS LOOSELY AND STAKE OR STAPLE TO MAINTAIN DIRECT CONTACT WITH THE SOIL. DO NOT STRETCH.

1994 JOHN McCULLAH

FILE: BLNKTSLP

ROLLED EROSION CONTROL PRODUCTS

11. Temporary Sediment Trap

Objectives and Applications

A temporary sediment trap is a small temporary ponding area, with a rock outlet, formed by excavating below grade and/or by constructing an earth embankment.

A sediment trap is a temporary structure that is used to detain runoff from small drainage areas so that sediment can settle out. Sediment traps generally are used for drainage areas less than five acres, and should be located in areas where access can be maintained for sediment removal and proper disposal. A sediment trap can be created by excavating a basin, utilizing an existing depression, or constructing a dam on a slight slope downward from a project area. Sediment laden runoff from the disturbed site is conveyed to the trap via ditches, slope drains, or diversion dikes. After being treated, the flow from the structure is controlled by a rock spillway. The trap is a temporary measure, with a design life of approximately six months, and is to be maintained until the site is permanently protected against erosion by vegetation and/or structures.

Common Failures - Generally due to faulty installation or maintenance

- Inadequate spillway size; this results in overtopping of dam, poor trap efficiency, and possible failure of the structure.
- Low point in embankment caused by inadequate compaction and settling; this can result in overtopping and possible failure.
- Outlet not extended to stable grade; this can result in erosion below the dam.
- Spillway stone size too small or backslope too steep; this may result in stone displacement.
- Inadequate storage capacity; the sediment is not removed from basin frequently enough.

Other Considerations

- The location of sediment traps should be determined based on the existing and proposed topography of the site.
- As a perimeter control, locate the trap where up to 5 disturbed acres drain to one location.

- Choose a location where maximum storage can be obtained from natural topography. This will minimize excavation.
- Locations should be selected where interference with construction activities will be minimized and will allow the trap to remain in service until the site is stabilized.
- The site must be accessible for future clean-out of the trap.
- Sediment traps are most effective at removing sand particles and are less effective at removing fine silt and clay particles. Longer retention times using engineered structures such as sediment basins or retention ponds may be necessary to remove these smaller particles.

Relationship to Other ESC Measures

Sediment traps are usually located at the outlets of diversions, channels, slope drains, or other runoff conveyances that discharge sediment laden water.

Alternate Sediment Control Measures

A sediment basin should be considered if the drainage area exceeds five acres. Sediment basins may be either temporary or permanent, and due to additional and more complex design and construction considerations, should be designed by a registered engineer.

Other Names

Catch Basin

Design

Design life: 1 season (6 months) or less

Contributing flow drainage area: not to exceed 5 acres

Storage volume: minimum 134 cubic yards per acre

Wet storage area depth: minimum 2 ft.- 3 ft., maximum 4 ft.

Ideal shape: rectangular and shallow trap, with a length to width ratio of 2:1 or greater

Berm: compacted earth, maximum height 5 ft.

Slopes (cut and fill): 2:1 or flatter

Outlet: rock spillway, crest of spillway 1.0 ft. below top of embankment.

Spillway weir length (minimum)	
Drainage area (Acres)	Weir length (Feet)
1 ac.	4 ft.
2 ac.	5 ft.
3 ac.	6 ft.
4 ac.	10 ft.
5 ac.	12 ft.

Stone size: construct outlet using well graded stones with a median stone size of 9 in. and a maximum stone size of 14 inches. A 12-in. thick layer of 1/2 to 3/4 in. aggregate should be placed on the inside face to reduce seepage flow rate.

Materials

Filter fabric, coarse aggregate or riprap 2 inches to 14 inches in diameter; washed gravel 1/2 inch to 3/4 inch in diameter, seed and mulch for stabilization.

Installation

Clear, grub, and strip the area under the berm of any vegetation and root mat. Clear the pool area to reduce debris buildup and facilitate cleanout. Excavate as required in the plan to obtain the necessary storage volume. Use fill material for the berm that is free of roots, other woody vegetation, organic materials, and large stones. Make all cut and fill slopes 2:1 or flatter. Compact the berm in 8 in. layers by traversing with construction equipment. Construct the rock spillway to the dimensions shown on the plan, placing filter fabric beneath the rock. Provide temporary or permanent stabilization (seed and mulch) on the berm immediately after the construction.

Inspection

Inspect temporary sediment traps weekly and after each period of significant rainfall. Check the structure for damage from erosion, and check rocks in the outlet for clogging with sediment. Check the height of the stone outlet to ensure that the crest is at least 12 in. below the top of the berm.

Maintenance

Remove sediment and restore trap to its original dimensions when the sediment has accumulated to one-half the design depth of the trap. Deposit sediment removed from the basin in a suitable area and in such a manner that it will not erode and cause sedimentation problems. Clean or replace the filter stone in the outlet structure if clogged with sediment. Adjust the height of the stone outlet if the crest is not at least 12 in. below the top of the berm.

Removal

Remove sediment traps after the contributing drainage area is stabilized. Grade and stabilize the site of the sediment trap after removal as shown in the plans.

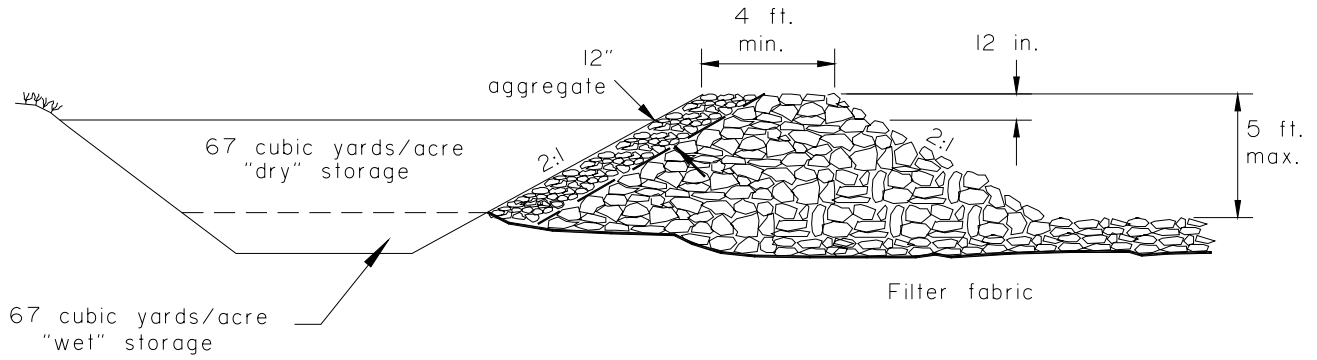

CROSS SECTION

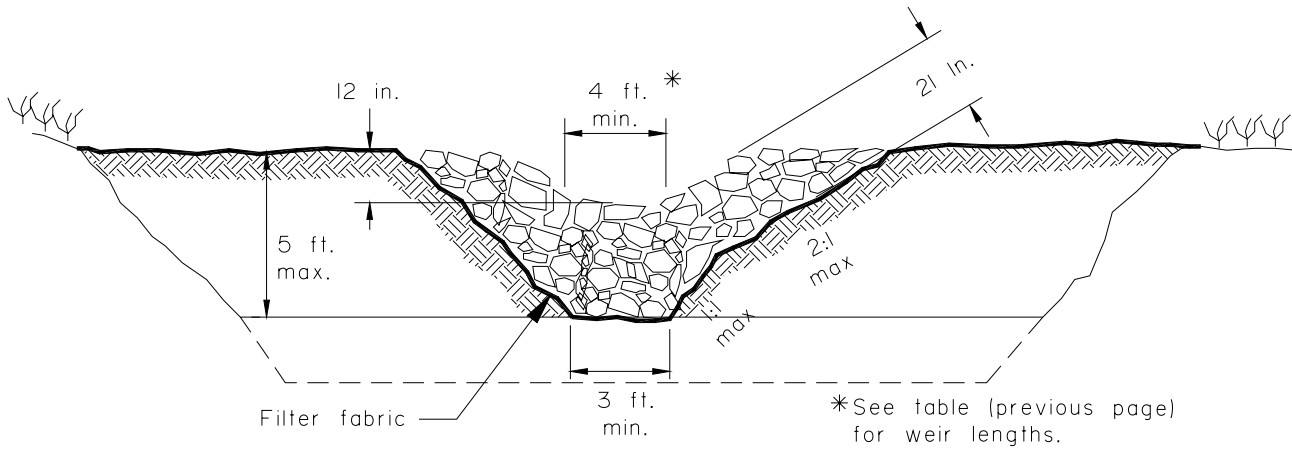

ELEVATION

TEMPORARY SEDIMENT TRAP

12. **Vegetative Buffer Strip**

Objectives and Applications

A vegetative buffer strip is an undisturbed area or strip of natural vegetation, or an established suitable planting that will provide a living filter to reduce soil erosion and runoff velocities.

Buffer strips act as living sediment filters that intercept and detain storm water runoff. They reduce the flow and velocity of surface runoff, promote infiltration, and reduce pollutant discharge by capturing and holding sediments and other pollutants in the runoff water. They may be natural, undeveloped land, or may be graded and planted with grass or other vegetation; and may be placed at many locations between the source of sediment (road surface, side slopes) and a natural or constructed waterway or other drainage area that could be impacted by deposits of sediment. Buffer strips may be used at any site that can support vegetation, but are best suited where soils are well drained and where the bedrock and water table are well below the surface. Buffer strips are particularly effective on flood plains, along stream banks, and at the top and bottom of a slope. Buffer strips may be either temporary or permanent.

Common Failures - Generally due to faulty installation or maintenance.

- Excessive sediment or oil and grease loads resulting in clogging.
- Introduction of storm water flows onto buffer strip before vegetation is established.

Other Considerations

- Not effective for filtering high velocity flows from large, paved areas, steep slopes, or hilly areas.
- May be more viable than silt fence where silt fence installation and removal will cause more harm than good.
- Avoid flow concentration
- Buffer strips generally only trap coarse sediments. Depending upon vegetative type, clay and fine silt particles will generally pass through a buffer strip during periods of heavy rain.

- Preserve natural vegetation in clumps, blocks or strips where possible, particularly in areas adjacent to waterways.
- Do not use planted or seeded ground as a buffer strip for sediment trapping until the vegetation is established.
- Extensive constructed buffers may increase development costs.

Relationship to Other ESC Measures

Buffer strips are used in conjunction with diversion measures such as earth dikes, diversions, and slope drains for slope protection. Silt fences placed upslope may prevent sediment overloading.

Alternate Sediment Control Measures

Diversion; Slope Drain

Other Names

Buffer Zone, Vegetated Filter Strip.

Design

Location: *Should be determined by considering slope, soil type, anticipated flow, and vegetation type.*

Capacity: *2 year peak runoff storm*

Width: *18 ft. - 60 ft., depending on type of vegetation and length of slope*

Grading: *smooth and uniform*

Permitting: *Wetland use as a vegetative buffer strip requires approval from the Corps of Engineers.*

Flow Distribution: *evenly distributed; avoid flow concentration*

Materials

Natural vegetation, seed or sod; fertilizer, mulch, water; fencing or flagging

Installation

Natural Vegetation

Delineate undisturbed natural areas of vegetation that have been identified on the plans with flagging prior to the start of construction activities. Ensure that other sediment control measures to be used in conjunction with the buffer strip are in place and functioning properly. Minimize construction activities and traffic in the buffer strip and immediate surrounding areas.

New Buffer Strip

Ensure that sediment control measures such as silt fence and diversions are in place to protect waterways or drainage areas until the buffer strip is established. Clear and grade the land according to the plans and specifications. Establish vegetation using specified seeding, mulching, watering, and fertilizer.

Inspection

Inspect natural vegetation buffer strip areas at regular intervals to ensure that the fencing or flagging used to delineate non-disturbance areas are in place. Check for damage by equipment and vehicles. Inspect new buffer strip areas for the progress of germination and plant growth. Ensure that water flowing through the area is not forming ponds, rills, or gullies due to erosion within the buffer strip.

Maintenance

Replace or repair fencing or flagging as necessary. Repair any damage by equipment or vehicles. Provide additional seed, fertilizer, and water to ensure adequate establishment of vegetation. Repair and reseed areas damaged by erosion or ponding of water.

Removal

Temporary buffer strips - Provide and compact fill to existing or specified grade. Seed and mulch.

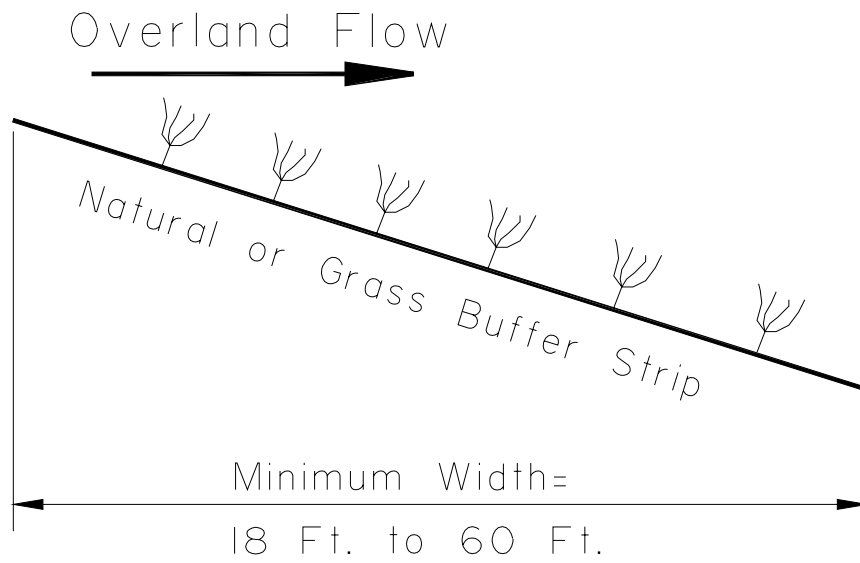

VEGETATIVE BUFFER STRIP

13. Silt Fence

Objectives and Applications

A silt fence is a perimeter control geotextile fence to prevent sediment in silt-laden sheet flow from entering sensitive receiving waters.

Silt fencing downslope from erosion-susceptible terrain traps sheet flow runoff before the drainage exits the project site. Intercepted drainage pools along the uphill side of the fence and standing water promote sediment settling out of suspension. Drainage in contact with the fence is filtered by the geotextile—the fabric’s small pores not only block eroded particles but also severely restrict water exfiltration rates.

Barrier locations are informally chosen based on site features and conditions (e.g. soil types, climate, terrain features, sensitive areas, etc.), design plans, existing and anticipated drainage courses, and other available erosion and sediment controls. Typical barrier sites are catchpoints beyond the toe of fill or on sideslopes above waterways or drainage channels. Silt fences are not recommended for wide low-flow, low-velocity drainageways, for concentrated flows, in continuous flow streams, for flow diversion, or as check dams. Use at drop or curb inlets is not appropriate for high volumes of stormwater.

Common Failures - Generally due to faulty installation or maintenance.

- Posts installed on uphill side of trench (instead of downhill side) or fabric attached to downhill side of posts (rather than uphill side).
- Slope erosion occurs below the fenceline due to drainage that bypasses the barrier end or water build-up that “blows out” a poorly secured fence bottom.
- Fence function impairment due to sediment build-up, maintenance neglect etc.
- Fence topples due to poor installation and/or high levels of impounded back-up water or sediment.
- Inappropriate for intended function (e.g. used for check dam, flow diversion, etc.).
- Uneven distribution of pooled drainage along non-level fenceline ground reduces efficiency.

- Poor support system (e.g. soil too rocky to secure posts, fabric stapled to trees, etc.).

Other Considerations

*Use of sediment control measures and the level of effort should be commensurate to the potential problem. **Silt fence is not to be used solely as a project delineator.** (Use barriers, flagging, etc. instead.)*

- Use of a silt fence sediment control measure is usually more complex, expensive and maintenance-prone than other slope stabilization measures.
- Slope stabilization should occur at the earliest possible time.
- Fenceline proximity to sensitive areas needing protection during fence installation, maintenance, removal, etc. (e.g. avoid equipment encroachment on wetlands).
- Undesirable effects of fence placement (e.g. a trench in ground that won’t readily “heal” after fence removal; undesirable effects of water back-up, ditch overflow, etc.).
- Equipment access route/space required for fence installation, maintenance and removal.

Relationship to Other ESC Measures

Sediment control measures are secondary to erosion prevention or soil stabilizing measures. Silt fences may be used as part of a sequential system with other temporary or permanent measures such as vegetation, check dams, settling ponds, etc. Occasional flow velocity increases may be offset using corrective measures such as rock berms or other redirecting energy absorbers.

Alternate Sediment Control Measures

Brush bundles or straw bales to filter small amounts of sediment in shallow gullies or ditches. Temporary settlement basin. Gravel berm. Triangular sediment filter dike (stand-alone wire mesh structure covered with filter fabric on uphill side [labor intensive to construct and maintain]).

Other Names

Geotextile for Sediment Control (sect 633 specifications), Filter Fence, Sediment Fence.

Design

Design life: 1 season (6 months) or less

Contributing sheet flow drainage area: not to exceed 0.25 acres/ 100 ft. of fence

Maximum Slope Length for Silt Fence		
Slope (%)	18 in. Fence	30 in. Fence
2 (or less)	250 ft.	500 ft.
5	100 ft.	250 ft.
10	50 ft.	150 ft.
15	35 ft.	100 ft.
20	25 ft.	70 ft.
25	20 ft.	55 ft.
30	15 ft.	45 ft.
35	15 ft.	40 ft.
40	15 ft.	35 ft.
45	10 ft.	30 ft.

Undisturbed buffer zone: At least 3.5 ft. from fence to downstream sensitive area

Support posts: at least 18 in. in the ground. Minimum trench size (x-section): 6"x 6"

Buried fabric: 18 in. (3 sides of trench)

Maximum spacing between posts: 6 ft.

Maximum fence height: 3 ft. above ground

Fabric joint overlap: minimum 6 in. at post not allowed in pooled drainage areas

Maximum height of ponding water: 18 in.

Maximum allowable depth of sediment accumulation against fence: 9 in.

Materials

Geotextile fabric sect 729-2.04 specification (AASHTO M 288 for Temporary Silt Fence except that minimum permittivity is .05/sec)

Support posts wood, steel or synthetic, adequate to support fence under field conditions

Staples or other means to attach fabric to posts

Installation

Install fences after site clearing but before excavation/ fill work. Erect fenceline downslope along a level contour and perpendicular to anticipated sheet flow drainage path(s). Orient end sections uphill slightly and install sufficient length to keep drainage from spilling around barrier ends. Where ground surfaces are uneven, install shorter fences following contours (rather than install one long, contour-crossing fence that directs drainage to accumulate in low spots). Locate fence 3-10 ft. beyond toe of fill to leave room for a broad, shallow sedimentation pool and for equipment access during fence maintenance and removal. Leave buffers between fencing and sensitive receiving areas.

Drive support posts into the ground, excavate a trench on the uphill side along the line of the stakes, attach geotextile, and bury fence bottom. Soil backfill trench and compact to secure fence bottom. (Compacted soil is preferred to gravel fill. Using sandbags or cement blocks to anchor the fence bottom is undesirable because of the tendency for undermining). Keep fence fabric taut. Do not field-sew seams. Overlap joints at support posts but do not place overlapped joints across pooled drainage areas.

Inspection

A properly installed fence intercepts sheet drainage, contains sediments on site and does not permit spillover or bypass. Inspect as needed daily, weekly, or during/ following major rainfall events.

Observe for fenceline continuity. Inspect fences for collapse, damage, undermine areas, compromised integrity, or other installation or functional inadequacies. Look for evidence of sediment or erosion flow leading off the downhill edge of the fence. (This may be an indicator of drainage bypass or fence undermine.) Note depth of sediment build up at the fence. Look for signs of inadequate protection of off-site sensitive areas. Observe turbidity levels of protected waterways and determine sources of sediment/siltation.

Maintenance

Repair functional deficiencies immediately. Reinforce fenceline as needed to prevent undesirable sedimentation of sensitive areas. Replace torn or punctured fabric. Remedy fence sags as needed. Periodically remove accumulated sediment and dispose of silt waste in approved manner/location (typically in a non-erosion area).

Removal

Do not remove until the disturbed area is permanently stabilized or sediment protection is no longer needed.

Unless directed otherwise, cut fabric at ground level, remove supports and spread sediment. Seed bare ground immediately. Discard filter fence as directed. Avoid damage to sensitive (e.g. wetland or surface water) areas. Stabilize areas.

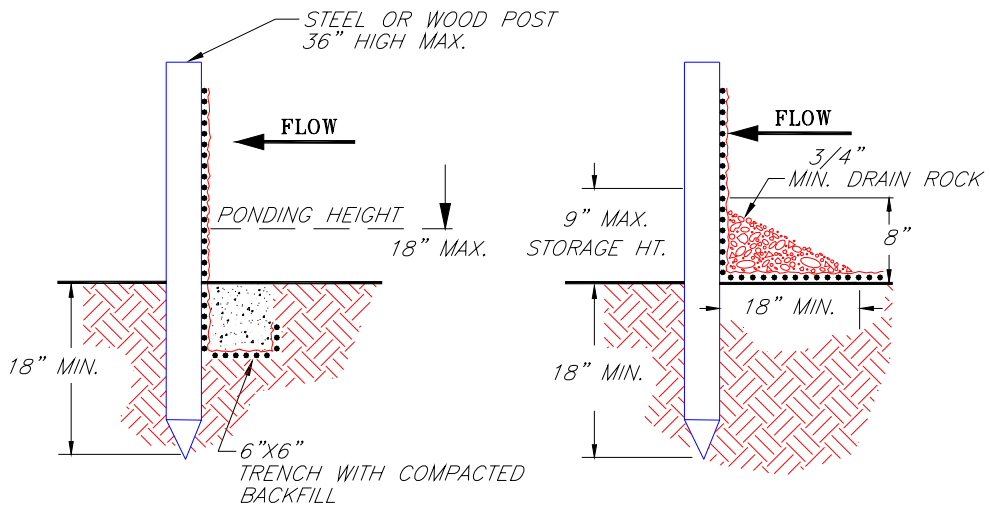
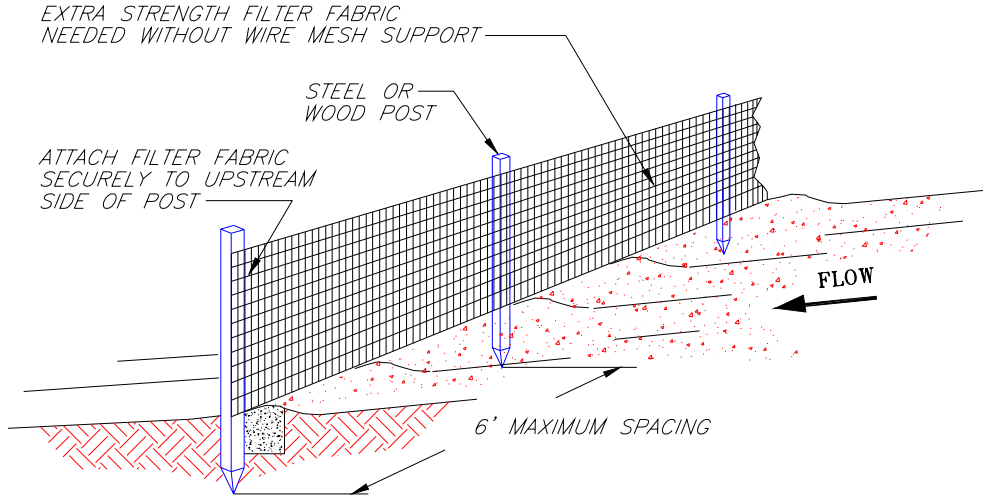

TRENCH DETAIL

INSTALLATION WITHOUT TRENCHING

NOTES:

1. SILT FENCE FOLLOWS SLOPE CONTOURS TO MAXIMIZE PONDING EFFICIENCY.
2. INSPECT AND REPAIR FENCE AFTER EACH STORM EVENT AND REMOVE SEDIMENT WHEN NECESSARY. 9" MAXIMUM SEDIMENT ACCUMULATION.
3. REMOVED SEDIMENT SHALL BE DEPOSITED TO AN AREA THAT WILL NOT CONTRIBUTE SEDIMENT AND CAN BE PERMANENTLY STABILIZED.

NOT TO SCALE

© 1994 JOHN McCULLAH
FILE: SILTFENC

SILT FENCE

14. Inlet Protection

Objectives and Applications

Inlet protection is a temporary filtering measure placed around a drop inlet or curb inlet to trap sediment and prevent the sediment from entering the storm drain system.

This measure is employed where storm drain inlets are to be made operational before permanent stabilization of the disturbed area, where a permanent storm drain structure is being constructed on site and there is potential for sediment accumulating in an inlet, and where ponding of storm water around the inlet structure could be a problem to the traffic on site. There are several types of sediment filters applicable for different conditions; the three most commonly used are:

filter fabric fence : applicable to drop inlets with flows 0.5 cfs or less, and flat grades (5 % or less).

block and gravel filter : applicable to drop and curb inlets with flows 0.5 cfs or more, flat grades (5 % or less), where no construction traffic will cross over the inlet.

gravel and wire mesh filter : applicable to drop and curb inlets with flows 0.5cfs or more, flat grades (5 % or less), where construction traffic will cross over the inlet.

Common Failures - Generally due to faulty installation or maintenance.

- Sediment accumulation – filtering capacity is reduced, resulting in ponding of water
- Improper installation, resulting in sediment bypassing filter and entering storm drain
- Tearing, undermining, or collapsing of filter fabric, resulting in sediment entering storm drain

Other Considerations

Inlet protection should be constructed in a manner that will facilitate cleanout and disposal of trapped sediment.

- Inlet protection should be constructed in a manner that will minimize ponding of storm water around the structure.
- Straw bale barriers should not be used for inlet protection.

Relationship to Other ESC Measures

Inlet protection is installed as a secondary measure to remove residual sediment that was not removed by other measures, such as check dams, grassed swales, and sediment traps.

Alternate Sediment Control Measures

Runoff from areas exceeding 1.0 acre or where grade is greater than 5% may require routing through a temporary sediment trap or sediment pond.

Other Names

Storm Drain Inlet Protection, Filter Inlet

Design

Drainage Area: *Not to exceed 1.0 acre*

Slope Gradient: *Not to exceed 5 %. For filter fabric fence designs, the area immediately surrounding the inlet should not exceed 1%. Gravel filters may be more appropriate for steeper slopes.*

Sediment Trapping Sump: *Where possible, a sump 12 in. – 20 in. measured from the crest of the inlet should be excavated. Side slopes should be 2:1. The recommended volume of excavation is 35 cubic yards/acre of disturbed ground.*

Orientation: *The longest dimension of the basin should be oriented toward the longest inflow area.*

Materials

Filter fabric fence – filter fabric (extra strength, filtering capacity 75 % minimum, meeting AASHTO Specification M 288 For Temporary Silt Fence); wooden stakes 2 in. x 4 in. – minimum length 3 ft.; heavy duty wire staples 1/2 in. long; washed gravel 3/4 in. – 1 ¼ in., with less than 5% fines.

Block and gravel filter – hardware cloth or wire mesh with 1/2 in. openings; filter fabric (optional) (AASHTO M 288); concrete blocks 4 in. – 12 in. wide, 12 in. – 24 in. high; washed gravel 3/4 in. – 4 in. in diameter; wood stud 2 in. x 4 in., for curb inlet applications.

Gravel and wire mesh filter - hardware cloth or wire mesh with 1/2 in. openings; filter fabric (AASHTO M 288); washed gravel 3/4 in. – 4 in. in diameter.

Installation

Filter Fabric Fence – Place a stake at each corner of the inlet no more than 3 ft. apart. Drive stakes into the ground a minimum of 12 inches. For stability, install a frame of 2 in. x 4 in. wood strips around the top of the overflow area. Excavate a trench 8 in. wide x-12 in. deep around the outside perimeter of the stakes. If a sediment trapping sump is being provided, then the excavation may be as deep as 20 inches. Staple the filter fabric to the wooden stakes with heavy duty staples; ensure that 32 in. of filter fabric extends at the bottom so it can be formed into the trench. Place the bottom of the fabric into the trench - backfill with washed gravel all the way around.

Block and Gravel Filter – Secure the inlet grate to prevent seepage. Place wire mesh over the inlet so that it extends 12 in. - 20 in. beyond the inlet structure. Place filter fabric (optional) over the mesh and extend it 20 in. beyond the inlet structure. Place concrete blocks over the wire mesh or filter fabric in a single row lengthwise on their sides, with the open ends of the blocks facing outward, not upward; ensure that adjacent ends of blocks abut. For curb inlet applications, cut a 2 in. x 4 in. wood stud the length of the curb inlet plus the width of the two end blocks and place the stud through the outer hole of the end blocks to keep the blocks in place. Place wire mesh over the outside of the vertical face (open end) of the blocks to prevent gravel from being washed through the blocks. Place gravel against the wire mesh to the top of the blocks.

Gravel and Wire Mesh Filter – Secure the inlet grate. Place wire mesh over the inlet so that the mesh extends 12 in. beyond each side of the inlet structure. Place filter fabric over the mesh, extending it 20 in. beyond the inlet structure. Place washed gravel over the fabric/wire mesh to a depth of 12 inches.

Inspection

Inspect inlet protection weekly and after every storm to look for sediment accumulation and structural damage.

Maintenance

Remove sediment and restore structure to its original dimensions when sediment has accumulated to ½ the

design depth. On gravel and mesh designs, clean (or remove and replace) the gravel filter or filter fabric if it becomes clogged. Repair any structural damage immediately.

Removal

Remove the filter material and support structures after the drainage areas have been completely stabilized. Remove or stabilize trapped sediment. Stabilize disturbed soil areas resulting from removal.

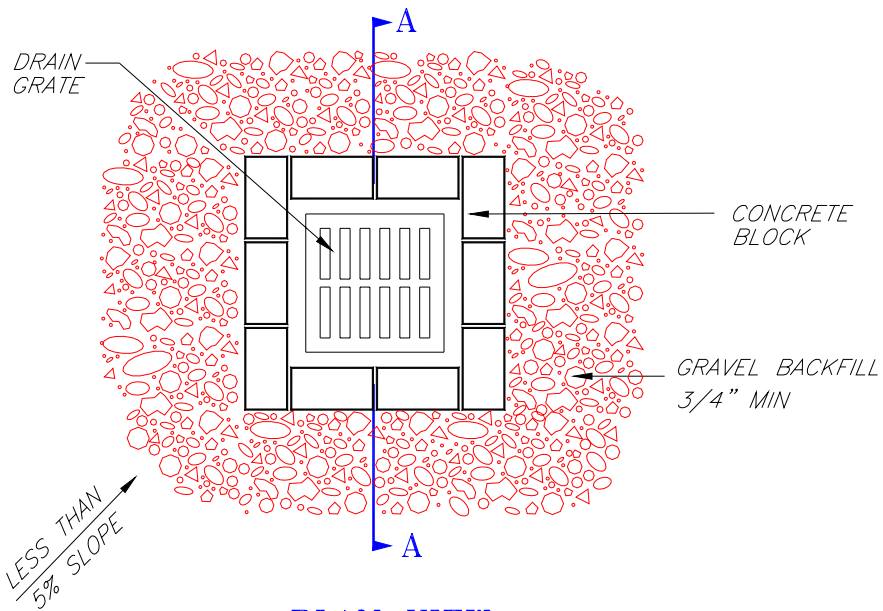

PLAN VIEW

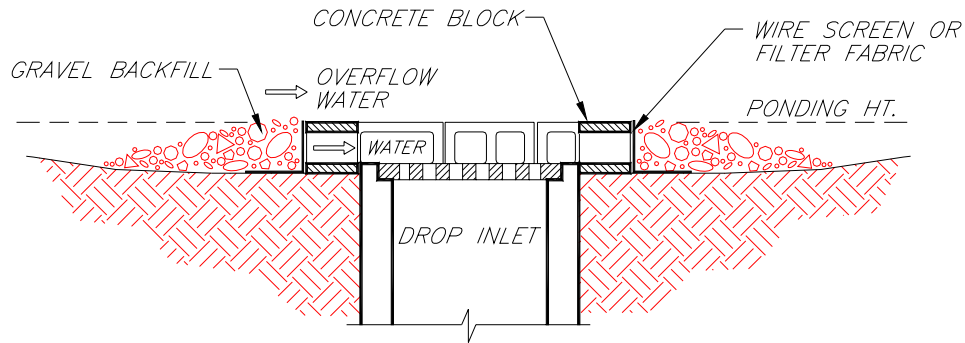

SECTION A - A

NOTES:

1. DROP INLET SEDIMENT BARRIERS ARE TO BE USED FOR SMALL, NEARLY LEVEL DRAINAGE AREAS. (LESS THAN 5%)
2. EXCAVATE A BASIN OF SUFFICIENT SIZE ADJACENT TO THE DROP INLET.
3. THE TOP OF THE STRUCTURE (PONDING HEIGHT) MUST BE WELL BELOW THE GROUND ELEVATION DOWNSLOPE TO PREVENT RUNOFF FROM BYPASSING THE INLET. A TEMPORARY DIKE MAY BE NECESSARY ON THE DOWNSLOPE SIDE OF THE STRUCTURE.

© 1994 JOHN McCULLAH

FILE: BGSEDBAR

INLET PROTECTION

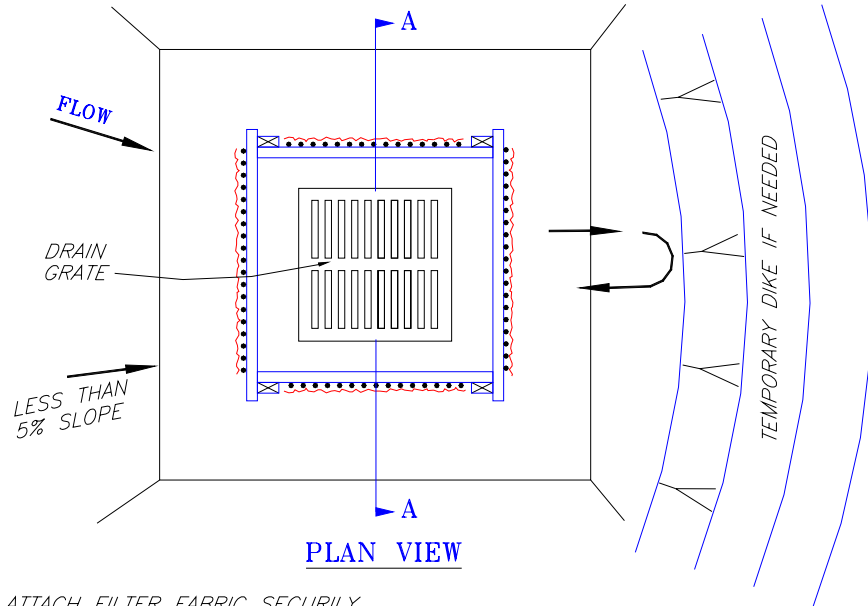

PLAN VIEW

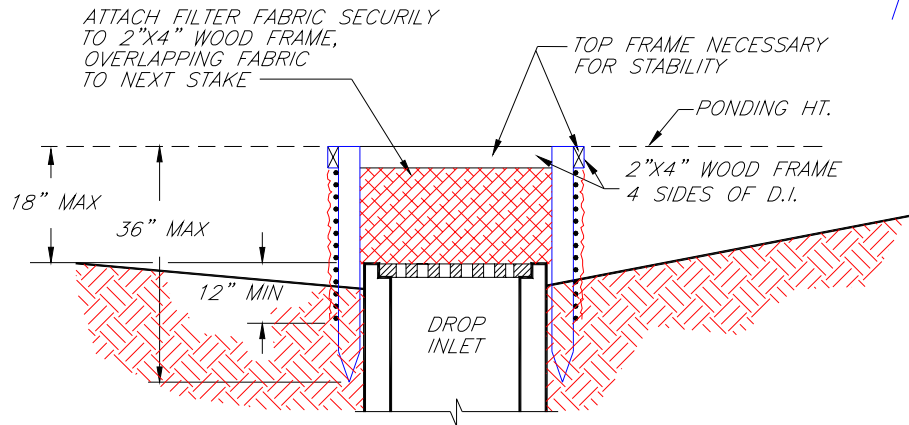

SECTION A-A

NOTES:

1. DROP INLET SEDIMENT BARRIERS ARE TO BE USED FOR SMALL, NEARLY LEVEL DRAINAGE AREAS. (LESS THAN 5%)
2. USE 2"x4" WOOD OR EQUIVALENT METAL STAKES, 3' MINIMUM LENGTH.
3. INSTALL 2"x4" WOOD TOP FRAME TO INSURE STABILITY.
4. THE TOP OF THE FRAME (PONDING HEIGHT) MUST BE WELL BELOW THE GROUND ELEVATION DOWNSLOPE TO PREVENT RUNOFF FROM BY-PASSING THE INLET. A TEMPORARY DIKE MAY BE NECESSARY ON THE DOWNSLOPE SIDE OF THE STRUCTURE.

NOT TO SCALE

© 1994 JOHN McCULLAHL
FILE: SILTFDIB

INLET PROTECTION

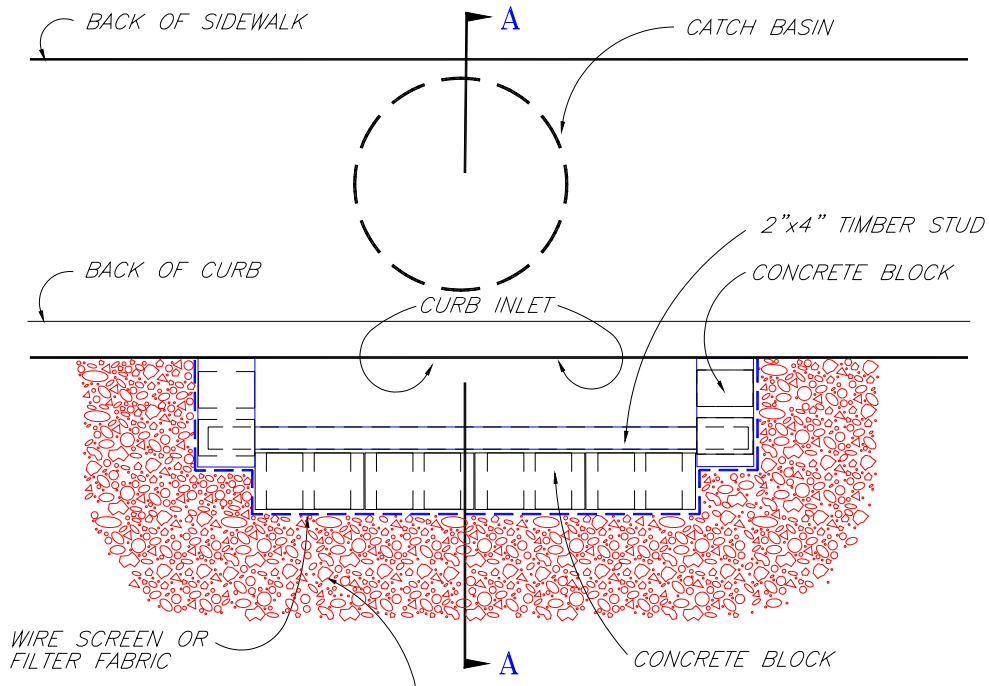

PLAN VIEW

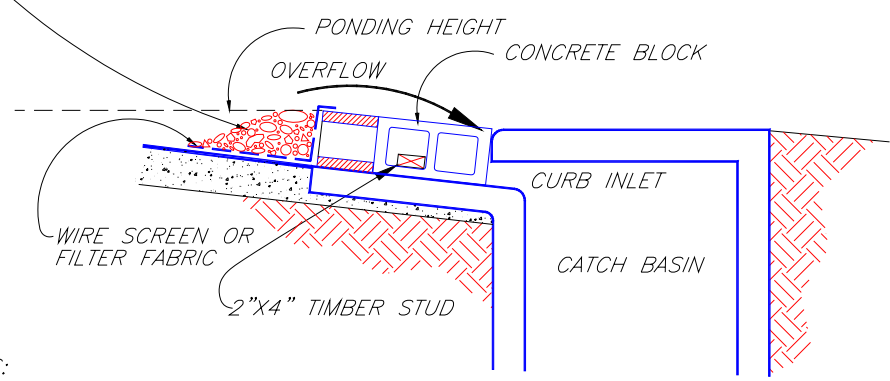

SECTION A - A

NOTES:

1. USE BLOCK AND GRAVEL TYPE SEDIMENT BARRIER WHEN CURB INLET IS LOCATED IN GENTLY SLOPING STREET SEGMENT, WHERE WATER CAN POND AND ALLOW SEDIMENT TO SEPARATE FROM RUNOFF.
2. BARRIER SHALL ALLOW FOR OVERFLOW FROM SEVERE STORM EVENT.
3. INSPECT BARRIERS AND REMOVE SEDIMENT AFTER EACH STORM EVENT. SEDIMENT AND GRAVEL MUST BE REMOVED FROM THE TRAVELED WAY IMMEDIATELY.

© 1994 JOHN McCULLAH
 FILE: BLCKCURB

INLET PROTECTION

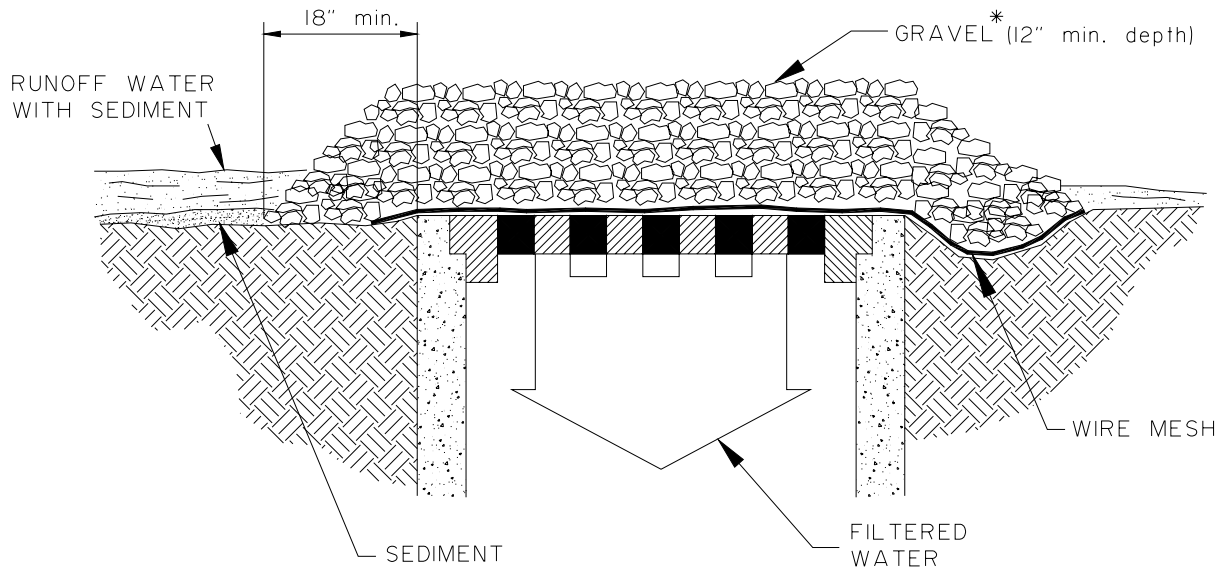

SPECIFIC APPLICATION

THIS METHOD OF INLET PROTECTION IS APPLICABLE WHERE HEAVY CONCENTRATED FLOWS ARE EXPECTED, BUT NOT WHERE PONDING AROUND THE STRUCTURE MIGHT CAUSE EXCESSIVE INCONVENIENCE OR DAMAGE TO ADJACENT STRUCTURES AND UNPROTECTED AREAS.

INLET PROTECTION

15. **Straw Bale Barrier**

Objectives and Applications

A straw bale barrier is a temporary sediment barrier consisting of a row of entrenched and anchored straw bales.

The purpose of a straw bale barrier is to intercept and retain sediment laden storm water runoff from disturbed areas of limited extent, preventing sediment from leaving the site; and to decrease the velocity of upslope sheet flows. The barrier is effective at the toe of embankment slopes, across minor swales and ditches, along property lines, and for other applications where the need for a barrier is temporary and structural strength is not required.

Common Failures - Generally due to faulty installation or maintenance.

- Lateral flanking of bales due to insufficient height or width, or due to ends of bales not flared upslope.
- Improper placement and installation, such as staking the bales directly onto the ground with no soil seal or entrenchment, allowing undercutting or end flow.
- Excessive gaps between bales are present, allowing water and sediment to escape.
- Sediment accumulation, resulting in loss of filtering capacity.

Other Considerations

- Straw bale barriers should not be constructed in streams or in swales where there is the possibility of a washout.
- Straw bale barriers should not be used on areas where rock or other hard surfaces prevents the uniform anchoring of the barrier.
- Straw bale barriers should not be constructed where flows are likely to exceed 0.3 cubic ft./second.
- Straw bale barriers should not be used where the control of sediment is critical, in high risk areas, or where ponded water could flow onto the roadway.

- Proper installation and maintenance are critical to the function of straw bale barriers.

Relationship to Other ESC Measures

Straw bale barriers may be used as silt traps and check dams. They function to reduce flow velocities and cause sediment deposition. They may also be used as a barrier to divert or direct runoff to a slope drain, sediment trap, or other control measure.

Alternate Sediment Control Measures

Silt Fence, Brush Barrier

Other Names

Erosion Bale, Straw Bale Dike, Straw Bale Sediment Trap

Design

Design life: 3 months or less

Contributing flow drainage area: not to exceed 0.25 acres per 100 ft. of bales

Maximum slope steepness: 2:1

Maximum flow path length to barrier: 150 ft.

Materials

Straw bales (wire bound or string tied), wood or metal stakes.

Installation

Excavate a trench the width of the bale and the length of the proposed barrier to a minimum depth of 4 in. Place the bales in a single row, lengthwise on the contour, with ends of the adjacent bales tightly abutting one another. If the barrier is located at the toe of a slope, place it 5 – 6 ft. away from the slope if possible. Ensure that all bales are wire-bound or string tied. Install bales so that bindings are oriented around the sides rather than along the tops and the bottoms of the bales in order to prevent deterioration of the bindings. Place and anchor each bale with at least two wood stakes, minimum dimensions, 2 in. x 2 in. x 36 in., or with # 4 reinforcing bars, driving the first stake toward the previously placed bale to force the bales together. Drive the stakes or reinforcing bars a minimum of 12 in. into the ground. Fill any gaps between bales with tightly wedged straw. Backfill

with excavated soil to ground level on the downhill side and up to 4 in. against the uphill side of the barrier.

Inspection

Inspect barrier weekly and immediately after each rainfall to look for sediment accumulation, damaged bales, end runs, and undercutting beneath bales.

Maintenance

Remove sediment deposits when they reach approximately one-half the height of the uphill edge of the barrier. Repair or replace damaged bales promptly.

Removal

Straw bale barriers and accumulated sediment may be spread and seeded; or may be removed after they have served their usefulness, but not before the upslope areas have been permanently stabilized with vegetation.

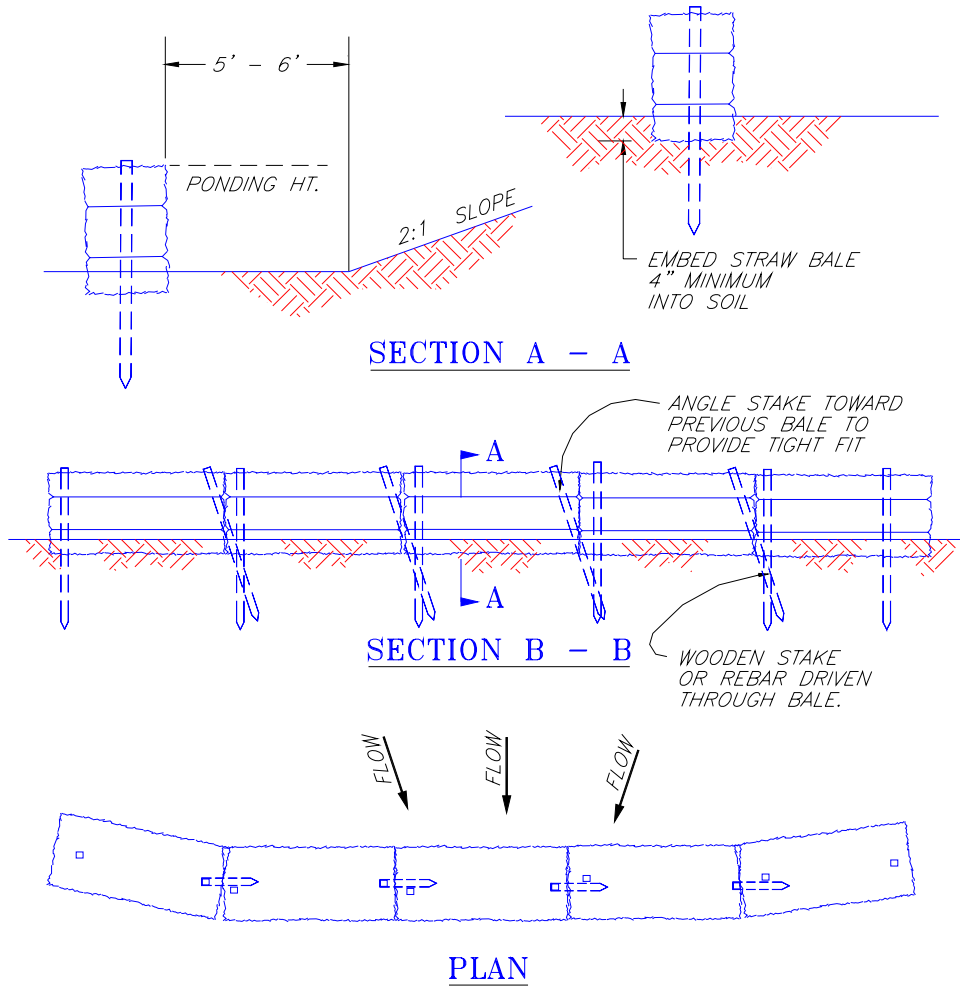

NOTES:

1. THE STRAW BALES SHALL BE PLACED ON SLOPE CONTOUR.
2. BALES TO BE PLACED IN A ROW WITH THE ENDS TIGHTLY ABUTTING.
3. KEY IN BALES TO PREVENT EROSION OR FLOW UNDER BALES.

© 1994 JOHN McCULLAH
FILE: STRWDIKE

STRAW BALE BARRIER

16. Brush Barrier

Objectives and Applications

A brush barrier is a temporary sediment barrier constructed at the perimeter of a disturbed site from the residual materials available from clearing and grubbing the site.

The purpose of a brush barrier is to intercept and retain sediment laden storm water runoff from disturbed areas of limited extent, preventing sediment from leaving the site. The barrier is constructed of tree limbs, weeds, vines, root mat, soil, rock, or other cleared materials piled together to form a berm, and located across or at the toe of a slope susceptible to sheet and rill erosion.

Common Failures - Generally due to faulty installation or maintenance.

- Materials that are too large are used, creating voids where sediment can easily pass through.
- Barrier constructed too loosely, allowing water and sediment to easily pass through.
- Sediment accumulation, resulting in loss of filtering capacity.

Other Considerations

- Enough residual material should be available on site for barrier construction.
- Material larger than 6 inches in diameter should not be used since it tends to create large voids.
- Barrier should be used only in areas of sheet or very low flow.
- Barrier should not be constructed where the maximum upslope gradient exceeds 2:1.
- Brush barriers should act as a filter, not a dam. If it is impermeable, then water will flow around it and outlet treatment will be required.

Relationship to Other ESC Measures

Brush barriers are utilized to retain sediment that would otherwise be deposited in other downslope sediment control measures, such as sediment traps and sediment ponds.

Alternate Sediment Control Measures

Straw Bale Barrier; Silt Fence

Other Names

Brush Berm, Brush Bundle

Design

Design life: *1 season (6 months) or less*

Contributing flow drainage area: *not to exceed 0.25 acres*

Height: *3 ft. minimum to 5 ft. maximum*

Width: (at base) *5 ft. minimum to 15 ft. maximum*

Materials

Residual on site materials from clearing and grubbing activities – brush, tree limbs, root mat, weeds, vines, rock, or other cleared materials; nylon or polypropylene rope, rebar stakes; geotextile fabric (optional) meeting AASHTO specification M 288 for temporary silt fence.

Installation

Construct the barrier to the specified height and width by piling brush, stone, root mat and other material from the clearing and grubbing process into a mounded row on the contour. Ensure that barrier structure is uniform and that no significant voids are present. Cover with geotextile fabric (optional). Anchor into the ground using 1/4 in. polypropylene or nylon rope tied across the berm in a crisscross fashion and secured to 18 in. long x 3/8 in. diameter rebar stakes.

Inspection

Inspect barrier weekly and after heavy rains to look for sediment accumulation.

Maintenance

Sediment deposits should be removed when they reach approximately one-third the height of the uphill edge of the barrier.

Removal

Brush barriers should be removed after they have served their usefulness, but not before the upslope areas have been permanently stabilized. Remove and stabilize trapped sediment. Stabilize disturbed soil areas resulting from removal. Brush barriers should only be left in-place if specifically allowed in the contract documents.

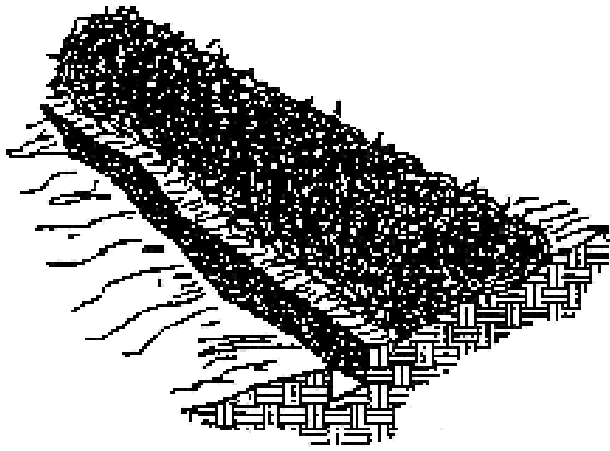

Excavate a 4" X 4" trench along the uphill edge of the Brush Barrier.

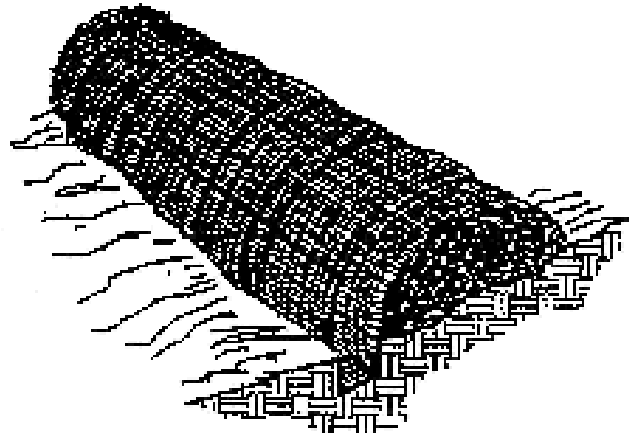

Drape a geotextile over the barrier and into the trench. The geotextile should be secured in the trench with stakes set approximately 36" on center.

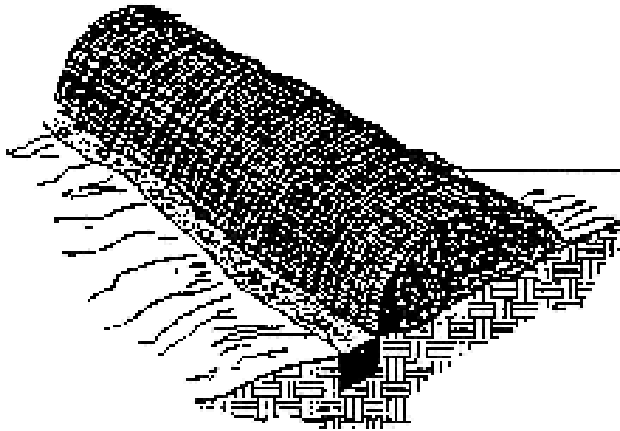

Backfill and compact the excavated soil.

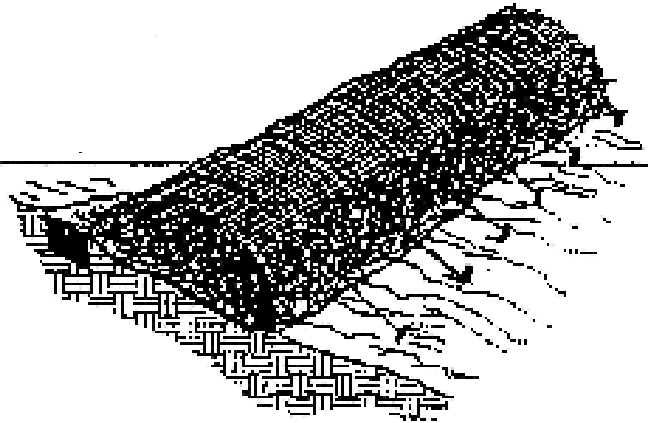

Set stakes along the downhill edge of the barrier, and anchor by tying twine from the geotextile to the stakes.

BRUSH BARRIER

17. Vehicle Tracking Entrance/Exit

Objectives and Applications

A vehicle tracking entrance/exit provides a stabilized gravel area or pad underlined with a geotextile and located where traffic enters or exits the construction site.

This measure establishes a buffer area for vehicles to deposit their mud and sediment, and minimize the amounts transported onto public roadways. Mud on a road can create a safety hazard as well as a sediment problem. This measure may be used with or without washdown, depending upon severity of problem.

Common Failures - Generally due to faulty installation or maintenance.

- Inadequate depth and length of gravel.
- Failure to periodically “top dress” (provide additional gravel) when sediment accumulates on the surface.
- Failure to repair and/or clean out any structures used to trap sediment.

Other Considerations

- Avoid entrances/exits which have steep grades or which are located where sight distance may be a problem.
- Provide drainage to carry water to sediment trap or other suitable outlet.

Design

Gravel Size: *2 in.-3 in.*

Pad Thickness: *minimum 6 in.*

Pad Width: *minimum 12 ft.*

Pad Length: *minimum 50 ft.*

Materials

Gravel, geotextile

Installation

Clear the entrance and exit area of all vegetation, roots, and other material and properly grade it. Place geotextile prior to placement of gravel. Place the gravel to the specific grade shown on the plans, and smooth it. Provide drainage to carry water to a sediment trap or other outlet.

Inspection

Inspect pads and sediment trapping structures daily for sediment accumulation and material displacement.

Maintenance

Maintain each entrance in a condition that will prevent tracking of mud or sediment onto public rights-of-way. Replace gravel material when surface voids are visible. Top dress with 2 in. gravel when pad becomes laden with sediment. Repair and/or clean out any structures used to trap sediment. Remove all mud and sediment deposited on paved roadways within 24 hours.

Removal

Remove pad and any sediment trapping structures after they are no longer needed, or within 30 days after final site stabilization. Remove and stabilize trapped sediment on site.

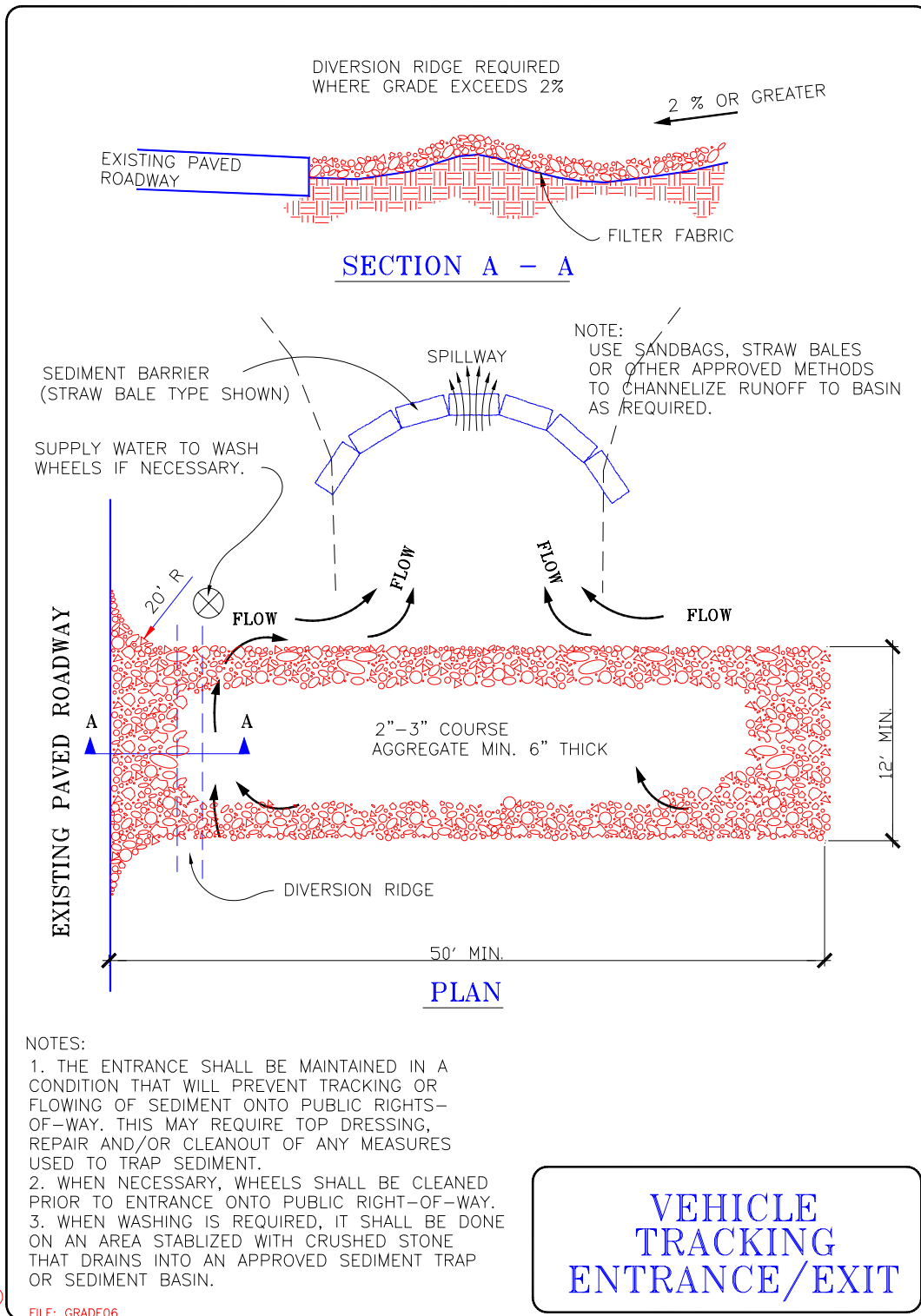

Vehicle Tracking Entrance/Exit