

City Council
January 11, 2016
Monday



Worksession 4:00 P.M.
Committee of the Whole 5:00 P.M.
Regular Meeting 6:00 P.M.

Cowles Council Chambers
City Hall
491 E. Pioneer Avenue
Homer, Alaska

Produced and
Distributed by the City Clerk's Office -1/7/2016-jj



January

- Monday 11th:** **CITY COUNCIL**
Worksession 4:00 p.m., Committee of the Whole 5:00 p.m., and Regular Meeting 6:00 p.m.
- Tuesday 12th:** **ECONOMIC DEVELOPMENT ADVISORY COMMISSION**
Regular Meeting 6:00 p.m.
- Thursday 14th:** **KACHEMAK DRIVE PHASE III WATER & SEWER SPECIAL ASSESSMENT DISTRICT**
Neighborhood Meeting 5:30 p.m.
- Wednesday 20th:** **PLANNING OMISSION**
Worksession 5:30 p.m. and Regular Meeting 6:30 p.m.
- Thursday 21st:** **SUSTAINABLE ANIMAL CONTROL REVIEW COMMITTEE**
Meeting 5:15 p.m.
- PARKS AND RECREATION ADVISORY COMMISSION**
Regular Meeting 5:30 p.m.
- Monday 25th:** **CITY COUNCIL**
Worksession 4:00 p.m., Committee of the Whole 5:00 p.m., and Regular Meeting 6:00 p.m.

Regular Meeting Schedule

City Council 2nd and 4th Mondays 6:00 p.m.

Library Advisory Board 1st Tuesday with the exception of January, April, August and November 5:30 p.m.

Economic Development Advisory Commission 2nd Tuesday 6:00 p.m.

Parks and Recreation Advisory Commission 3rd Thursday with the exception of July, December and January 5:30 p.m.

Planning Commission 1st and 3rd Wednesday 6:30 p.m.

Port and Harbor Advisory Commission 4th Wednesday 5:00 p.m. (May-August 6:00 p.m.)

Cannabis Advisory Commission 4th Thursday 5:30 p.m.

Public Arts Committee Quarterly 2nd Thursday 5:00 p.m.

Permanent Fund Committee Quarterly 2nd Thursday 5:15 p.m.

MAYOR AND CITY COUNCILMEMBERS AND TERMS

BETH WYTHER, MAYOR – 16

BRYAN ZAK, COUNCILMEMBER - 16

DAVID LEWIS, COUNCILMEMBER – 17

GUS VAN DYKE, COUNCILMEMBER – 16

CATRIONA REYNOLDS, COUNCILMEMBER – 17

DONNA ADERHOLD, COUNCILMEMBER – 18

HEATH SMITH, COUNCILMEMBER – 18

City Manager, Katie Koester

City Attorney, Thomas F. Klinkner

<http://cityofhomer-ak.gov/cityclerk> for home page access, Clerk's email address is: clerk@ci.homer.ak.us Clerk's office phone number: direct line 235-3130, other number 435-3106

HOMER CITY COUNCIL
491 E. PIONEER AVENUE
HOMER, ALASKA
www.cityofhomer-ak.gov



WORKSESSION
4:00 P.M. MONDAY
JANUARY 11, 2016
COWLES COUNCIL CHAMBERS

MAYOR BETH WYTHE
COUNCIL MEMBER DAVID LEWIS
COUNCIL MEMBER BRYAN ZAK
COUNCIL MEMBER GUS VAN DYKE
COUNCIL MEMBER CATRIONA REYNOLDS
COUNCIL MEMBER DONNA ADERHOLD
COUNCIL MEMBER HEATH SMITH
CITY ATTORNEY THOMAS KLINKNER
CITY MANAGER KATIE KOESTER
CITY CLERK JO JOHNSON

WORKSESSION AGENDA

1. CALL TO ORDER, 4:00 P.M.

Councilmember Reynolds has requested excusal.

2. AGENDA APPROVAL (Only those matters on the noticed agenda may be considered, pursuant to City Council's Operating Manual, pg. 5)

3. PUBLIC SAFETY BUILDING OPTIONS

4. COMMENTS OF THE AUDIENCE

5. ADJOURNMENT NO LATER THAN 4:50 P.M.

Next Regular Meeting is Monday, January 25, 2016 at 6:00 p.m., Committee of the Whole 5:00 p.m., and a Worksession 4:00 p.m. All meetings scheduled to be held in the City Hall Cowles Council Chambers located at 491 E. Pioneer Avenue, Homer, Alaska.

From: [Mary Griswold](#)
To: [Renee Krause](#); [Jo Johnson](#)
Subject: additional comments for Public Safety Building packet
Date: Tuesday, December 29, 2015 10:14:05 AM

MG additional comments on Public Safety Building Options 12.29.15

If some features of Option 2 will be incorporated into the new Option 1, I offer the following observations:

- 1 The warren of fire department bunk rooms needs a convenient bathroom. A domestic clothes washer and dryer are also desirable.
2. The watch office is still a critical necessity.
3. Although the access from the living area to the apparatus bays is not shown, it should not be across the living room carpet. There should be a hallway extension from the lobby, similar to what I proposed for the original Option 1. Responders, staff, mechanics, school tour groups, and others require access between the apparatus bays and the downstairs offices and same floor training and exercise rooms without tracking dirt across the living room carpet or walking between the couch and TV or interrupting a pool game.
4. The hose washer and turnout washer in the fire apparatus support section should be moved to the apparatus bays where they will be closer to the hose storage and responders' turnout gear stalls.

The space above the fire apparatus support section should be enclosed as part of the apparatus bays for cost-effective storage of large bulky items.

A restroom in the apparatus bays is highly desirable.

5. The kitchen of the fire living section and the training room are too far apart. Fire department training is frequently accompanied by pizza or ice cream laid out on the kitchen table. This should be convenient.
6. Could we make good use of the "open to below" space on the second floor?
7. The 59 foot dimension for the apparatus bays in Option 2 is excellent to incorporate into the new Option 1.
8. I support building a long-term police station ASAP while performing maintenance and repairs on the existing fire station. I do not support adding space to the existing station. However, before we complete the plans for the new police station, the fire department component must be satisfactorily designed so we know a long-term fire station will fit on this site in about 8 years.



MAYOR BETH WYTHE
COUNCIL MEMBER DAVID LEWIS
COUNCIL MEMBER BRYAN ZAK
COUNCIL MEMBER GUS VAN DYKE
COUNCIL MEMBER CATRIONA REYNOLDS
COUNCIL MEMBER DONNA ADERHOLD
COUNCIL MEMBER HEATH SMITH
CITY ATTORNEY THOMAS KLINKNER
CITY MANAGER KATIE KOESTER
CITY CLERK JO JOHNSON

COMMITTEE OF THE WHOLE AGENDA

1. CALL TO ORDER, 5:00 P.M.

Councilmember Reynolds has requested excusal.

2. AGENDA APPROVAL (Only those matters on the noticed agenda may be considered, pursuant to City Council's Operating Manual, pg. 6)

3. Ordinance 16-01, An Ordinance of the City Council of Homer, Alaska, Amending Homer City Code 2.08.030, Composition of Governing Body – Terms of Office, Homer City Code 4.35.010, Review of Election Documents by Canvass Board, and Homer City Code 4.40.010, Runoff Election – Required; and Enacting Homer City Code 4.35.020, Votes Required to be Elected, Homer City Code 4.35.030, Tie Vote, And Homer City Code 4.35.040, Certification of Election; Regarding the Procedure for Electing the Mayor and Council Members. Mayor. Recommended dates: Introduction January 11, 2016, Public Hearing and Second Reading January 25, 2016. **Page 95**

Memorandum 16-003 from City Clerk as backup. **Page 103**

4. Memorandum 16-001, from Mayor Wythe, Re: Appointment of a Person to be Named to the Kenai Peninsula Economic Development District. **Page 291**

5. Memorandum 16-008, from City Clerk, Re: 2016 Meeting Schedule. **Page 11**

6. CONSENT AGENDA

7. REGULAR MEETING AGENDA

8. COMMENTS OF THE AUDIENCE

9. ADJOURNMENT NO LATER THAN 5:50 P.M.

Next Regular Meeting is Monday, January 25, 2016 at 6:00 p.m., Committee of the Whole 5:00 p.m., and Worksession 4:00 p.m. All meetings scheduled to be held in the City Hall Cowles Council Chambers located at 491 E. Pioneer Avenue, Homer, Alaska.



City of Homer

www.cityofhomer-ak.gov

Office of the City Clerk

491 East Pioneer Avenue
Homer, Alaska 99603

clerk@cityofhomer-ak.gov

(p) 907-235-3130

(f) 907-235-3143

Memorandum 16-008

TO: MAYOR WYTHER AND HOMER CITY COUNCIL

FROM: JO JOHNSON, CITY CLERK

DATE: JANUARY 6, 2016

SUBJECT: MEETING SCHEDULE FOR 2016

There are several important matters for the Council to discuss in 2016 and agendas are filling up quickly. The Council may wish to schedule Worksessions outside the regular meeting dates to tackle these subjects in a timely manner.

Subjects include:

HART/HAWSP Assessment Methodology

Revenue Enhancement Issues/Long Term Planning

A schedule for Strategic Doing Worksessions was set for 2015 via Resolution 14-119. If Council wishes to set a schedule to continue Strategic Doing, dates can be selected for 2016 and a resolution will follow to solidify the schedule.

RECOMMENDATION: Determine if additional Worksessions are needed for 2016.

Fiscal Note: N/A

CALL TO ORDER
PLEDGE OF ALLEGIANCE
AGENDA APPROVAL

HOMER CITY COUNCIL
491 E. PIONEER AVENUE
HOMER, ALASKA
www.cityofhomer-ak.gov



REGULAR MEETING
6:00 P.M. MONDAY
JANUARY 11, 2016
COWLES COUNCIL CHAMBERS

MAYOR BETH WYTHE
COUNCIL MEMBER DAVID LEWIS
COUNCIL MEMBER BRYAN ZAK
COUNCIL MEMBER GUS VAN DYKE
COUNCIL MEMBER CATRIONA REYNOLDS
COUNCIL MEMBER DONNA ADERHOLD
COUNCIL MEMBER HEATH SMITH
CITY ATTORNEY THOMAS KLINKNER
CITY MANAGER KATIE KOESTER
CITY CLERK JO JOHNSON

REGULAR MEETING AGENDA

Worksession 4:00 p.m. and Committee of the Whole 5:00 p.m. in Homer City Hall Cowles Council Chambers.

1. CALL TO ORDER, PLEDGE OF ALLEGIANCE

Councilmember Reynolds has requested excusal.

Department Heads may be called upon from time to time to participate via teleconference.

2. AGENDA APPROVAL

(Addition of items to or removing items from the agenda will be by unanimous consent of the Council. HCC 1.24.040.)

3. PUBLIC COMMENTS UPON MATTERS ALREADY ON THE AGENDA

4. RECONSIDERATION

5. CONSENT AGENDA

(Items listed below will be enacted by one motion. If separate discussion is desired on an item, that item may be removed from the Consent Agenda and placed on the Regular Meeting Agenda at the request of a Councilmember.)

- A. Homer City Council unapproved Regular meeting minutes of December 7, 2015. City Clerk. Recommend adoption.

Page 27

- B. **Memorandum 16-002**, from Deputy City Clerk, Re: Liquor License Renewals for BPO Elks Lodge #2127, Kharacters, AJ's Old Town Steakhouse & Tavern, Captain Patties Fish House, Café Cups, Finn's, Little Mermaid, The Alibi, Salty Dawg Saloon, Down East Saloon, Pho & Thai Restaurant, and Grog Shop East End. **Page 53**

- C. **Ordinance 16-01**, An Ordinance of the City Council of Homer, Alaska, Amending Homer City Code 2.08.030, Composition of Governing Body – Terms of Office, Homer City Code 4.35.010, Review of Election Documents by Canvass Board, and Homer City Code 4.40.010, Runoff Election – Required; and Enacting Homer City Code 4.35.020, Votes Required to be Elected, Homer City Code 4.35.030, Tie Vote, and Homer City Code 4.35.040, Certification of Election; Regarding the Procedure for Electing the Mayor and Council Members. Mayor. Recommended dates: Introduction January 11, 2016, Public Hearing and Second Reading January 25, 2016. **Page 95**

Memorandum 16-003 from City Clerk as backup. **Page 103**

- D. **Ordinance 16-02**, An Ordinance of the Homer City Council Amending the 2016 Operating Budget by Appropriating Funds in the Amount of \$20,000 From Port and Harbor Reserves to Purchase Eight Light Emitting Plasma (LEP) Lamps for the Fish Dock. City Manager/Port and Harbor Director. Recommended dates: Introduction January 11, 2016, Public Hearing and Second Reading January 25, 2016. **Page 105**

Memorandum 16-007 from Port and Harbor Director as backup. **Page 109**

- E. **Ordinance 16-03**, An Ordinance of the City Council of Homer, Alaska Amending Ordinance 13-03(S)(2) to State the Actual Principal Amount of, and Change the Payment Dates for, the Natural Gas Distribution Special Assessment Bond Authorized by Ordinance 13-02, and Authorizing an Amendment to the Loan Agreement Between the City and the Kenai Peninsula Borough Regarding the Bond. City Manager. Recommended dates: Introduction January 11, 2016, Public Hearing and Second Reading January 25, 2016. **Page 115**

- F. **Resolution 16-001**, A Resolution of the Homer City Council Confirming the City Manager's Appointment of Jo Johnson as Acting City Manager and Mark Robl as Backup Acting City Manager for Calendar Year 2016. City Manager. Recommend adoption. **Page 141**

- G. **Resolution 16-002**, A Resolution of the Homer City Council Confirming the Appointments of Zhiyong Li as Treasurer and Jenna deLumeau as Deputy Treasurer for Calendar Year 2016. City Manager. Recommend adoption. **Page 143**
- H. **Resolution 16-003**, A Resolution of the City Council of Homer, Alaska, Acknowledging the December 2015 Surplus Equipment Bid Results. City Clerk. Recommend adoption. **Page 145**
- I. **Resolution 16-004**, A Resolution of the City Council of Homer, Alaska, Authorizing the City Manager to Dispose of Used and Surplus Equipment Pursuant to HCC 18.30.010 and HCC 18.30.040(b). City Manager. Recommend adoption. **Page 153**
- Memorandum 16-009 from City Manager as backup. **Page 157**
- J. **Resolution 16-005**, A Resolution of the Homer City Council Excluding Kenai Peninsula Borough Parcel 17708014 Owned by Cook Inlet Region, Inc. from the Homer Natural Gas Special Assessment District. City Manager. Recommend adoption. **Page 159**
- K. **Resolution 16-006**, A Resolution of the Homer City Council Adopting an Alternative Allocation Method for the FY16 Shared Fisheries Business Tax Program and Certifying that this Allocation Method Fairly Represents the Distribution of Significant Effects of Fisheries Business Activity in the Cook Inlet Fisheries Management Area. City Manager. Recommend adoption. **Page 165**
- L. **Resolution 16-007**, A Resolution of the City Council of Homer, Alaska, in Support of Full Funding for the State of Alaska Harbor Facility Grant Program in the FY 2017 State Capital Budget. City Manager/Port and Harbor Director. Recommend adoption. **Page 167**
- M. **Resolution 16-008**, A Resolution of the City Council of Homer, Alaska, Supporting the Establishment of a Syringe Exchange Program in Homer. Lewis. Recommend adoption. **Page 171**
- N. **Resolution 16-009**, A Resolution of the City Council of Homer, Alaska, Requesting That Any Additional Taxes Levied Against Commercial Marijuana Activities by the Kenai Peninsula Borough, on Businesses Located Within the Municipal Boundaries of Homer, Alaska, is Remitted to the City of Homer. Reynolds/Cannabis Advisory Commission. Recommend adoption. **Page 173**

- O. **Memorandum 16-004**, Travel Authorization for Mayor Wythe and Councilmembers Lewis and Reynolds to Travel to Juneau to Advocate for the City February 2 – 4, 2016. Recommend adoption. **Page 175**
- P. **Memorandum 16-005**, Travel Authorization for Councilmember Zak to Travel to Anchorage to Attend the Alaska Housing Summit January 6, 2016. **Page 177**
- Q. **Memorandum 16-006**, from City Clerk, Re: Amendment of Resolution 15-105 for March 2016 Meeting Schedule of Council. **Page 179**

6. VISITORS

- A. Fire Chief Painter, All-Hazard Mitigation Plan Update, 10 minutes.
- B. Arni Thomson, Alaska Salmon Alliance, Economic Impact of the Seafood Industry in Southcentral Alaska, 10 minutes. **Page 189**

7. ANNOUNCEMENTS/PRESENTATIONS/BOROUGH REPORT/COMMISSION REPORTS

- A. EMT Swearing In
- B. Mayor’s Recognition – Homer High Wrestling Team **Page 211**
- C. Borough Report
- D. Commissions/Board Reports:
 - 1. Library Advisory Board
 - 2. Homer Advisory Planning Commission
 - a. Minutes of December 2, 2015 **Page 217**
 - 3. Economic Development Advisory Commission
 - 4. Parks and Recreation Advisory Commission
 - 5. Port and Harbor Advisory Commission
 - 6. Cannabis Advisory Commission

- E. Thank you from Cook Inletkeeper **Page 231**

- F. Thank you from Nordic Ski Club **Page 233**

- G. Letters to Council, Re: Crosswalks and a Rec Center **Pages 235/237**

- 8. PUBLIC HEARING(S)**

- 9. ORDINANCE(S)**

- 10. CITY MANAGER’S REPORT**

 - A. City Manager’s Report **Page 245**

 - B. Bid Report **Page 259**

- 11. CITY ATTORNEY REPORT**

- 12. COMMITTEE REPORT**

 - A. Public Arts Committee

 - B. Permanent Fund Committee

 - C. Employee Committee Report

 - D. Public Safety Building Review Committee

 - E. Sustainable Animal Control Review Committee

- 13. PENDING BUSINESS**

 - A. **Ordinance 15-43**, An Ordinance of the City Council of Homer, Alaska, Repealing Homer City Code Chapter 3.12, Permanent Fund, Placing the Funds in a Self-Managed Brokerage and Disbanding the Permanent Fund Committee. City Clerk/Permanent Fund Committee. Introduction November 23, 2015, Public Hearing and Second Reading December 7, 2015, Postponed to January 11, 2016. **Page 267**

Ordinance 15-43(S), An Ordinance of the City Council of Homer, Alaska, Amending Homer City Code 3.10.130, Governance of Homer Permanent Fund Assets, Regarding the Management of Investments of the Homer Permanent Fund. City Clerk/Permanent Fund Committee. Recommend: Public Hearing January 25, 2016. **Page 271**

Memorandum 15-190 from Permanent Fund Committee as backup. **Page 275**

B. **Resolution 15-109**, A Resolution of the Homer City Council to Support the Repair and Reopening of Rocky River State of Alaska Road Easement to the Gulf of Alaska. Mayor. Recommend adoption. Postponed to January 11, 2016. **Page 277**

14. NEW BUSINESS

A. **Memorandum 16-001**, from Mayor Wythe, Re: Appointment of a Person to be Named to the Kenai Peninsula Economic Development District. **Page 291**

15. RESOLUTIONS

16. COMMENTS OF THE AUDIENCE

17. COMMENTS OF THE CITY ATTORNEY

18. COMMENTS OF THE CITY CLERK

19. COMMENTS OF THE CITY MANAGER

20. COMMENTS OF THE MAYOR

21. COMMENTS OF THE CITY COUNCIL

22. ADJOURNMENT

Next Regular Meeting is Monday, January 25, 2016 at 6:00 p.m., Committee of the Whole 5:00 p.m., and Worksession 4:00 p.m. All meetings scheduled to be held in the City Hall Cowles Council Chambers located at 491 E. Pioneer Avenue, Homer, Alaska.

PUBLIC COMMENTS
UPON MATTERS
ALREADY ON THE AGENDA

RECONSIDERATION

CONSENT AGENDA

Session 15-35 a Regular Meeting of the Homer City Council was called to order on December 7, 2015 at 6:00 p.m. by Mayor Mary E. Wythe at the Homer City Hall Cowles Council Chambers located at 491 E. Pioneer Avenue, Homer, Alaska, and opened with the Pledge of Allegiance.

PRESENT: COUNCILMEMBERS: ADERHOLD, LEWIS, REYNOLDS, SMITH, VAN
DYKE, ZAK (telephonic)

STAFF: CITY MANAGER KOESTER
CITY CLERK JOHNSON
CITY ATTORNEY KLINKNER
ASSISTANT CITY MANAGER LAWRENCE
DEPUTY HARBORMASTER CLARKE
FINANCE DIRECTOR LI
IT MANAGER POOLOS
LIBRARY DIRECTOR DIXON
PERSONNEL DIRECTOR BROWNING
POLICE CHIEF ROBL
PORT AND HARBOR DIRECTOR HAWKINS

Councilmember Zak has requested telephonic participation.

Mayor Wythe called for a motion to allow Councilmember Zak to participate by telephone.

LEWIS/REYNOLDS - SO MOVED.

There was no discussion.

VOTE: YES. NON OBJECTION. UNANIMOUS CONSENT.

Motion carried.

Council met as a Committee of the Whole from 5:00 p.m. to 5:23 p.m. to discuss Consent and Regular Agenda Meeting items.

Department Heads may be called upon from time to time to participate via teleconference.

AGENDA APPROVAL

(Addition of items to or removing items from the agenda will be by unanimous consent of the Council. HCC 1.24.040.)

The following changes were made: **ANNOUNCEMENTS** - AML Newly Elected Officials Conference Report from Councilmember Smith; **PUBLIC HEARINGS - Ordinance 15-41(S)**, An Ordinance of the Homer City Council Appropriating Funds for the Calendar Year 2016 for the General Fund, the Water Fund, the Sewer Fund, the Port/Harbor Fund, Capital Projects, and Internal Service Funds. City Manager. Budget Amendment Lobbyist/Library Books – Councilmember Smith. Homer Public Library Statistics. Written public comments; **RESOLUTIONS - Resolution 15-104(S)**, A Resolution of the City Council Certifying the Results of the City of Homer Special Election Held December 1, 2015 to Decide Proposition #1 “Shall the Dedication of 0.75% of the City Sales Tax to the Homer Accelerated Roads and Trails (H.A.R.T.) Program be Suspended for a Period of Three Years, to Make Such 0.75% of City Sales Tax Available for General Government Purposes?” City Clerk/Canvass Board; **Resolution 15-110(S)**, A Resolution of the City Council of Homer, Alaska, Approving a New One-Year Contract With Premera Blue Cross and Assurant Health. City Manager.

Mayor Wythe called for a motion for the approval of the agenda as amended.

LEWIS/REYNOLDS - SO MOVED.

There was no discussion.

VOTE: YES. NON OBJECTION. UNANIMOUS CONSENT.

Motion carried.

PUBLIC COMMENTS UPON MATTERS ALREADY ON THE AGENDA

Pat Brown, Chair of the Library Advisory Board and Economic Development Advisory Commission, appreciates what Council is doing to resolve the financial issues and support a viable stable government and economic development.

Ken Castner, city resident, commented on Mayor Wythe’s comments on November 23 pertaining to the HERC building and opposes charging interest on condominium natural gas assessments. He doesn’t support Resolution 15-106, but does fully support Resolution 15-111.

Ginny Espenshade, city resident, is supportive of the presentation by Dr. Spencer. In her research on 26 year-olds living in Homer, 10% to 11% of them have heroin court cases. Prevention, education, and support will help to save lives from overdoses.

Ted Schmidt, city resident, opposes Resolutions 15-106 and 15-111. The HART proposition (Resolution 15-104) was presented in a subjective manner. Additionally, it is disingenuous to be after the public to pay for infrastructure for public safety expansion.

RECONSIDERATION

CONSENT AGENDA

(Items listed below will be enacted by one motion. If separate discussion is desired on an item, that item may be removed from the Consent Agenda and placed on the Regular Meeting Agenda at the request of a Councilmember.)

- A. Homer City Council unapproved Regular meeting minutes of November 23, 2015. City Clerk. Recommend adoption.

- B. **Memorandum 15-196**, from Deputy City Clerk, Re: Liquor License New Application for Grace Ridge Brewing, Inc.

- C. **Resolution 15-105**, A Resolution of the City Council of Homer, Alaska, Establishing the 2016 Regular Meeting Schedule for the City Council, Economic Development Advisory Commission, Library Advisory Board, Parks and Recreation Advisory Commission, Advisory Planning Commission, Port and Harbor Advisory Commission, Cannabis Advisory Commission, Permanent Fund Committee, and Public Arts Committee. City Clerk. Recommend adoption.

Memorandum 15-197 from Parks and Recreation Advisory Commission as backup.
Memorandum 15-200 from Cannabis Advisory Commission as backup.
Memorandum 15-201 from Planning Commission as backup.
Memorandum 15-202 from Library Advisory Board as backup.
Memorandum 15-203 from Port and Harbor Advisory Commission as backup.

- D. **Resolution 15-107**, A Resolution of the City Council of Homer, Alaska, Noting the Insufficiency of the Petition for Lambert Lane and Lakeshore Drive Road Reconstruction and Paving Special Assessment District. City Clerk. Recommend adoption.

- E. **Resolution 15-109**, A Resolution of the Homer City Council to Support the Repair and Reopening of Rocky River State of Alaska Road Easement to the Gulf of Alaska. Mayor. Recommend adoption.

Item E, Resolution 15-109 was moved to Resolutions, Item F. Aderhold.

Mayor Wythe called for a motion for the approval of the recommendations of the consent agenda as read.

LEWIS/REYNOLDS – SO MOVED.

There was no discussion.

VOTE: YES. NON OBJECTION. UNANIMOUS CONSENT.

Motion carried.

VISITORS

A. Lobbyist Linda Anderson, Anderson Group

Linda Anderson has been a contract lobbyist since 1985 and the City's lobbyist since 2011. When the State of Alaska had a lot of money the goal was to make sure Homer had capital projects. She works with the Homer delegation very closely. The lobbyist is tasked with covering every hearing that might affect Homer in proposed legislation.

Last year there was no capital budget. Homer was treated fairly, as nobody got anything. The budget crisis is more extreme than the State has faced before. We probably won't get a capital budget for Homer, but she can assure Homer will have a seat at the table and she will represent Homer's position on state sales tax. There will be legislation of consolidating services of boroughs and cities, statewide bed taxes and sin taxes on alcohol, cigarettes, and cannabis. AML can take only broad general positions on issues and the lobbyists meet with AML weekly and share ideas.

Business for 2016 includes state retirement funds and unfunded liability. Currently municipalities are paying back 22% for the unfunded liability. The Legislature believes it is a bonus the municipalities only pay back 22% yet the problem was created by the State, not the municipalities. There will be a proposal to change the dollar amount in the operating budget. There are also termination costs to allow municipalities to manage their work force. The State exempted themselves from requirements of termination costs, but municipalities cannot. It is one of the issues that has to be resolved. Before June the Legislature must pass a budget. If they included the Permanent Fund and sales tax they are still a billion dollars under water. By June the Legislature has to vote on a constitutional amendment to advance the LNG gas line for it to appear on the November 2016 ballot. If this is not done by June it pushes the LNG project back two years. An agreement with the producers and parties is required.

B. Dr. Sarah Spencer, South Peninsula Hospital, Needle Exchange for Heroin Use

Dr. Sarah Spencer is board certified in heroin addiction and works in between South Peninsula Hospital and Ninilchik. The syringe exchange can be controversial. The heroin epidemic is nationwide and is here in Homer. The needle exchange program is a means to reduce the spread of disease and lower health care costs. The syringe exchange generally provides free distribution of sterile syringes and collects used syringes. The main goal is to reduce transmission of blood borne infections of HIV and Hepatitis C and skin and bacterial related infections. Other services include referral for testing HIV, substance abuse counseling, and prevention. Half of all IV drug users will be infected with Hepatitis C. In 2010 Alaska spent \$7.5M on HIV and \$7.3M on hepatitis related to drug use. In the Homer area it is estimated 100 to 300 people are injecting drugs. Syringe exchange programs are cost effective versus the cost of treating Hepatitis C and bacterial infections involving skin. The exchange has shown a slight reduction of drug use. Every major medical group strongly supports syringe exchange programs. There is no program on the Kenai Peninsula Borough; the closest one is Anchorage. Grants are available for the exchange program, the hospital could help with disposal, and volunteers would be needed to staff it along with a space for it to occur. Dr. Spencer can be reached in Ninilchik at 907-567-3970 or sarahspencerak@gmail.com.

The Council discussed sponsoring a resolution in support of a needle exchange program on the lower peninsula.

C. Brandon Nyberg, Wells Fargo Insurance Services, Health Insurance

Brandon Nyberg, Wells Fargo Insurance Services, reported it was challenging to keep the health insurance benefits' renewal at 10% or below for 2016. An 8.77% increase for the City was delivered by negotiating with the carriers. Premera will continue as the carrier and we will change to Assurant for dental and vision benefits. Life insurance will remain with Prudential. When negotiations began Wells Fargo started with a 16.84% increase and had to work to negotiate to an 8.77% increase from 2015 rates. The major change in health benefits is the limitation of spinal manipulations to 12 visits per year. The pharmacy remains the same. Assurant provided a two-year rate guarantee for vision and Prudential has a rate lock on life insurance. Premera did not offer a network for dental and vision, but Assurant has a network. Medical rates are driven by claims and the City had high claims that provided a challenge in renewal.

ANNOUNCEMENTS/PRESENTATIONS/BOROUGH REPORT/COMMISSION REPORTS

A. Borough Report

B. Commissions/Board Reports:

1. Library Advisory Board

2. Homer Advisory Planning Commission

a. Minutes of November 4, 2015

Tom Stroozas, Vice Chair of the Planning Commission, reported on the marathon meeting of December 2nd. The commission decided two Conditional Use Permits (CUP), a vacation and preliminary plat, and the draft marijuana ordinance. It was a five-hour meeting that adjourned at 10:30 p.m. The CUP was approved to build four duplexes on the lot off Calhoun Trail with many people testifying. The vacation of right-of-way access easement on Waddell Way was approved and the project will commence shortly to align Lake and Heath streets. The commission approved a CUP on the lot for the Quicky Mart with several conditions. A preliminary plat near Bayview Park was considered. Discussion on marijuana regulations included liability to the City when additional regulations are added, concerns for regulations that would encourage retail businesses next to town, and those that may encourage the black market. Discussion will continue at the January 6th meeting along with a public hearing.

3. Economic Development Advisory Commission

Ken Sprague, Economic Development Advisory Commissioner, reported Port and Harbor Director Bryan Hawkins visited the commission to talk about LNG projects moving forward. Karen Zak of the Chamber of Commerce made a presentation on the Chamber of Commerce marketing campaign. The Chamber is doing a lot for the City on a limited budget. Councilmember Zak also mentioned the City's website budget adjustments. The Alaska Small Business Innovators did a presentation about the women challenge to promote and support women businesses.

4. Parks and Recreation Advisory Commission

Deb Lowney, Parks and Recreation Advisory Commissioner, reported the commission has purchased doggy bag dispensers and personal doggie bag dispensers. The maintenance department will work on placement of the large dispensers while parks and recreation will work on locating the personal dispensers. She encouraged people to pick up after their pets. The commission discussed Bayview Park where early childhood development is doing upgrades and volunteer work. They have been asked to provide what is needed at the park. The fence is a safety issue and trails are needed. Other items of discussion have been the Greatland trail, the Glen Forrest connection to Homer Middle School, Calhoun trail, and the sidewalk from Soundview to Mullikin. The commission supports all the trails. Discussion on the HERC continues with pressure from the public for use of the space and to work to make the building self-sustaining. The commission hopes to see progress with the Beach Policy

proposal. In reference to Dr. Spencer's comments on drug use, it is here in our backyards and on our beaches. That message was brought to us strongly when working on the beaches.

5. Port and Harbor Advisory Commission
6. Cannabis Advisory Commission

Councilmember Lewis reported the commission has been meeting once a month. They have been discussing cannabis grow operations in rural residential districts and limiting the number of businesses. They have decided they will let the businesses work it out as to how many dispensaries are allowed.

- C. AML Newly Elected Officials Conference Report from Councilmember Smith

Mayor Wythe called for a recess at 7:02 p.m. and reconvened the meeting at 7:10 p.m.

PUBLIC HEARING(S)

- A. **Ordinance 15-37**, An Ordinance of the Homer City Council Amending HCC 9.16.010 to Provide for an Increase in the Rate of the City Sales Tax From 4.5% to 5.5% From April 1st Through September 30th, With the Increase to be Used for General Government Purposes, and Authorizing the City To Submit the Question of Such Sales Tax Increase to the Qualified Voters of The City at a Special Election to Be Held in the City on _____. Lewis. Introduction October 12, 2015, Postponed to December 7, 2015 for Public Hearing and Second Reading.

Mayor Wythe opened the public hearing.

Barb Brodowski, city resident, is against the ordinance as written as it will raise tax on non-prepared food from 7.5% to 8.5%. She would like Council to either exclude the tax on non-prepared food or inform the public now we will be paying 8.5% tax on food in June, July, and August.

Ken Castner, city resident, suggested the Council take some time to look at the budget situation more comprehensively, as we don't want to keep piecemealing things. We only have a finite means of collecting revenues; sales tax can fund operations of city government.

Crisi Matthews, city resident, commented on the sales tax increase. Homer already has the highest tax in the state and the cost for families is too much. She calculated a family of six spending four days in Homer with hotel, food, and a fishing trip would pay \$526 in sales tax.

Christian Matthews, city resident and son of Crisi Matthews, told Council sales tax is a bad idea since it affects families.

Tom Zitzmann, city resident, commented sales tax impacts those that can afford to pay the least. He praised the City for putting together a well thought out budget. We need to look at a budget of 3, 5, and 10 years out and determine how to finance it. We can't continue to put employees in a fear based situation.

Scott Adams, city resident, suggested tabling the ordinance since we just voted in HART to help pay for government for three years. Use that time to find a solution instead of presenting more taxes. We first need to figure out what the State and Borough are going to do with reduced revenue.

Mayor Wythe closed the public hearing.

Mayor Wythe called for a motion for the adoption of Ordinance 15-37 by reading of title only for second and final reading.

LEWIS/REYNOLDS – SO MOVED.

LEWIS/REYNOLDS - MOVED TO AMEND LINE 12 AND HAVE IT AT A GENERAL ELECTION INSTEAD OF A SPECIAL ELECTION.¹

There was no discussion.

VOTE: (amendment) YES. NON OBJECTION. UNANIMOUS CONSENT.

Motion carried.

LEWIS/REYNOLDS - MOVED TO POSTPONE TO THE MAY 9TH MEETING.

The Council discussed postponing the ordinance to find out what the State and Borough are going to do. The ordinance was brought forward as plan B in the event that the HART fund vote did not pass. The Council will be looking at a long term plan for revenue.

VOTE: (postponement) YES. NON OBJECTION. UNANIMOUS CONSENT.

Motion carried.

¹ All references to special election were amended to a regular election.

- B. **Ordinance 15-41(S)**, An Ordinance of the Homer City Council Appropriating Funds for the Calendar Year 2016 for the General Fund, the Water Fund, the Sewer Fund, the Port/Harbor Fund, Capital Projects, and Internal Service Funds. City Manager. Introduction October 26, 2015, Public Hearings November 23 and December 7, 2015, Second Reading December 7, 2015.

Memorandum 15-176 from Library Director as backup.

Memorandum 15-178 from Community Recreation Manager as backup.

Memorandum 15-180, 15-195, and 15-205 from City Manager as backup.

Mayor Wythe opened the public hearing.

Adele Person, city resident, supports the two projects on Soundview to make it safer for children and citizens. There is \$7M in the HART fund for the projects; it will make a big improvement and costs won't get cheaper in the future.

Mayor Wythe closed the public hearing.

Mayor Wythe called for a motion for the adoption of Ordinance 15-41(S) by reading of title only for second and final reading.

LEWIS/REYNOLDS - SO MOVED.

LEWIS/ADERHOLD - MOVED TO AMEND TO ADD THE SUBMERSIBLE PUMP AT \$8,500 FOR PUBLIC WORKS WATER WITH THE WATER RESERVE.

There was no discussion.

VOTE: YES. NON OBJECTION. UNANIMOUS CONSENT.

Motion carried.

REYNOLDS/LEWIS - MOVED TO AMEND ORDINANCE 15-41(S) TO ADD \$40,000 AS A CAPITAL PROJECT FOR WEST HOMER ELEMENTARY SOUNDVIEW SAFETY IMPROVEMENTS WITH HART FUNDS.

Councilmember Aderhold disclosed a potential conflict of interest as her husband works on capital projects for the City of Homer Public Works.

City Attorney Klinkner asked if Councilmember Aderhold's husband's compensation may improve with new projects. City Manager Koester answered the compensation may change since Councilmember Aderhold's husband is a temporary project based employee as opposed to being built into the budget. City Attorney Klinkner advised Councilmember

Aderhold to excuse herself. Compensation of more than \$1,000 in an instance and more than \$5,000 in a year creates a conflict of interest.

Mayor Wythe ruled Councilmember Aderhold was excused. There was no objection from the Council.

Councilmember Aderhold was excused.

The improvements will be by West Homer Elementary to provide crosswalks. The sidewalk is further up from the school so this project will not include speed bumps or crosswalks in the general area of the sidewalk.

VOTE: YES. NON OBJECTION. UNANIMOUS CONSENT.

Motion carried.

LEWIS/REYNOLDS - MOVED TO ADD THE CALHOUN TRAIL WORK \$12,500 AS A CAPITAL PROJECT WITH HART FUNDS.

There was no discussion.

VOTE: YES. NON OBJECTION. UNANIMOUS CONSENT.

Motion carried.

REYNOLDS/LEWIS - MOVED TO AMEND ORDINANCE 15-41(S) TO ADD SOUNDVIEW SIDEWALK EXTENSION \$315,000 AS A CAPITAL PROJECT WITH HART ROADS FUND.

There is no obligation to spend the full fund if the project is less than the estimate. The type of sidewalk will be decided when the project documents are brought before Council.

VOTE: YES. NON OBJECTION. UNANIMOUS CONSENT.

Motion carried.

Councilmember Aderhold returned to her seat.

REYNOLDS - MOVED TO AMEND ORDINANCE 15-41(S) TO REDUCE COUNCIL COMPENSATION TO FUND LIBRARY BOOKS \$8,864 IN THE GENERAL FUND.

Motion died for lack of a second.

REYNOLDS/LEWIS - MOVED TO AMEND ORDINANCE 15-41(S) TO ADD EXPANSION OF HICKERSON CEMETERY \$200,000 AS A CAPITAL PROJECT FROM PARKS AND GENERAL FUND.

Councilmember Aderhold was excused due to conflict of interest (Public Works project).

City Manager Koester amended the project to do it in phases. The amount is \$200,000 to develop less than half of the plots. There are currently eleven unsold plots remaining in the existing cemetery. The cost of plots will be raised to \$1,000 per Resolution 15-097(S) effective January 1st.

VOTE: YES. NON OBJECTION. UNANIMOUS CONSENT.

Motion carried.

Councilmember Aderhold returned to her seat.

VAN DYKE/SMITH – MOVED TO AMEND TO ELIMINATE THE LOBBYIST CONTRACT AND FUND LIBRARY AND PORT AND HARBOR RESERVES.

Councilmember Aderhold disclosed a potential conflict of interest since her stepdaughter works at the library.

City Attorney Klinkner asked Councilmember Aderhold if the acquisition of books will have any effect on her stepdaughter's compensation. Councilmember Aderhold answered it would not and City Attorney Klinkner advised there would be no conflict.

The lobbyist is paid \$40,000 per year and is reimbursed for one trip to Homer per year from \$350 - \$700. There are extra funds for lobbying activities of the Council.

Council discussed the advantages of having a lobbyist to keep us informed of what is happening in Juneau and what cuts we may expect. The lobbyist can keep track of administrative and law changes that will impact us. When there is no money the Legislature is changing rules and laws.

Disadvantages to extending the lobbyist contract are that the capital budget is flat-lined. There are major issues that affect municipalities and that is what AML and the elected officials do. We don't have the money for the lobbyist and will have to lean more heavily on our elected officials.

VOTE: YES. SMITH, REYNOLDS, VAN DYKE

VOTE: NO. LEWIS, ADERHOLD, ZAK

Mayor Wythe broke the tie vote with a NO vote.

Motion failed.

ADERHOLD/REYNOLDS - MOVED TO REDUCE COUNCIL COMPENSATION IN ORDER TO FUND LIBRARY BOOKS THROUGH THE GENERAL FUND.

Council compensation was brought forward last year by Councilmember Burgess. Some individuals may want to run for council but need compensation to leave work early or care for their kids. Council may donate their compensation back to the City or a charity of their choice if they don't need it.

VOTE: (amendment) YES. ADERHOLD, REYNOLDS

VOTE: NO. LEWIS, ZAK, SMITH, VAN DYKE

Motion failed.

VOTE: (main motion as amended) YES. REYNOLDS, ADERHOLD, VAN DYKE, ZAK, SMITH, LEWIS

Motion carried.

C. **Resolution 15-097(S)**, A Resolution of the City Council Amending the City of Homer Fee Schedule Under Administrative, Animal Control, City Clerk, Camping, Library, Public Safety, Fire Department, and Public Works Department Fees. City Clerk. To Follow Budget Ordinance 15-41(S).

Memorandum 15-175 from City Clerk as backup.

Memorandum 15-184 from Sustainable Animal Control Review Committee as backup.

Mayor Wythe opened the public hearing. In the absence of public testimony Mayor Wythe closed the public hearing.

Mayor Wythe called for a motion for the adoption of Resolution 15-097(S) by reading of title only.

LEWIS/REYNOLDS – SO MOVED.

REYNOLDS/LEWIS - MOVED TO ADD A WHEREAS THIS IS EFFECTIVE JANUARY 1, 2016.

There was no discussion.

VOTE: (amendment) YES. NON OBJECTION. UNANIMOUS CONSENT.

Motion carried.

VOTE: (main motion as amended) YES. NON OBJECTION. UNANIMOUS CONSENT.

Motion carried.

- D. **Ordinance 15-42**, An Ordinance of the Homer City Council, Amending HCC 7.04.010, State Statutes Adopted by Reference, HCC 7.04.030, Violation—Penalty, and HCC 10.04.100, Vehicles and Other Wheeled Conveyances, Repealing HCC Chapter 7.08, Stopping or Parking, and Enacting HCC Chapter 7.10, Stopping, Standing and Parking, to Incorporate in the City Code All Vehicle and Traffic Statutes and Regulations of the State of Alaska Creating Minor Offenses and to Revise and Consolidate City Parking Regulations, and to Prescribe Penalties for Traffic and Parking Violations. City Manager/Police Chief. Introduction November 23, 2015, Public Hearing and Second Reading December 7, 2015.

Memorandum 15-189 from City Attorney as backup.

Mayor Wythe opened the public hearing.

Ken Castner, city resident, commented Hazel Street will be the only road that allows on-street parking. Council will regret doing this since people can be ticketed for \$25 for parking in areas not allowed.

Scott Adams, city resident, expressed concern about parking vehicles with a “for sale” sign since parking for 24 hours would be a violation. From April through June people are selling vehicles and boats on the Spit.

Mayor Wythe closed the public hearing.

Mayor Wythe called for a motion for the adoption of Ordinance 15-42 by reading of title only for second and final reading.

ADERHOLD/LEWIS – SO MOVED.

City Attorney Klinkner advised the police department asked for this ordinance to coordinate the issuance of citation procedure with the State for the fine schedule and traffic offenses. There were some omissions and this will cure the problem.

Police Chief Robl told Council it will not change the way the police address parking as to what is in the books.

VOTE: YES. NON OBJECTION. UNANIMOUS CONSENT.

Motion carried.

- E. **Ordinance 15-43**, An Ordinance of the City Council of Homer, Alaska, Repealing Homer City Code Chapter 3.12, Permanent Fund, Placing the Funds in a Self-Managed Brokerage and Disbanding the Permanent Fund Committee. City Clerk/Permanent Fund Committee. Introduction November 23, 2015, Public Hearing and Second Reading December 7, 2015.

Memorandum 15-190 from Permanent Fund Committee as backup.

Mayor Wythe opened the public hearing.

Ken Castner, city resident, referenced lines 14 and 15, noting we have not generated income to support city government, nor have we chosen the Permanent Fund as a source of revenue. We need to put it to use as a real investment for things we need. Having money for the sake of having it is not a great idea.

Mayor Wythe closed the public hearing.

Mayor Wythe called for a motion for the adoption of Ordinance 15-43 by reading of title only for second and final reading.

LEWIS/REYNOLDS – SO MOVED.

REYNOLDS/LEWIS – MOVED THAT WE WOULD DISTRIBUTE THE PERMANENT FUND TO THE RESERVE FUNDS TO BRING THEM TO THE LEVEL THAT IS SUGGESTED BY BEST PRACTICES.

Mayor Wythe commented the concept of the fund is sound and we have one opportunity to spend it, but have many opportunities to reserve it for the future. It would be used in a way that was beneficial to the community long term. Moving it in-house is step one but before disbursement there would be a lot of conversation and a vote from the people.

VOTE: YES. VAN DYKE

VOTE: NO. LEWIS, REYNOLDS, ZAK, ADERHOLD, SMITH

Motion failed.

LEWIS/SMITH - MOVED TO POSTPONE TO OUR FIRST MEETING IN JANUARY.

There was no discussion.

VOTE: (postponement) YES. NON OBJECTION. UNANIMOUS CONSENT.

Motion carried.

- F. **Ordinance 15-44**, An Ordinance of the City Council of Homer, Alaska, Amending the FY 2015 Operating Budget by Making Necessary Adjustments to Certain Revenue and Expenditure Line Items. City Manager/Finance Director. Introduction November 23, 2015, Public Hearing and Second Reading December 7, 2015.

Mayor Wythe opened the public hearing. In the absence of public testimony Mayor Wythe closed the public hearing.

Mayor Wythe called for a motion for the adoption of Ordinance 15-44 by reading of title only for second and final reading.

LEWIS/REYNOLDS – SO MOVED.

There was no discussion.

VOTE: YES. NON OBJECTION. UNANIMOUS CONSENT.

Motion carried.

- G. **Ordinance 15-45**, An Ordinance of the City Council of Homer, Alaska, Amending the FY 2015 Operating Budget by Appropriating Funds in the Amount of \$2,540.30 to Purchase Refurbished Touch Screen Voting Units for the City's Two Precincts. City Manager/City Clerk. Introduction November 23, 2015, Public Hearing and Second Reading December 7, 2015.

Ordinance 15-45(S), An Ordinance of the City Council of Homer, Alaska, Amending the FY 2015 Operating Budget by Appropriating Funds in the Amount of ~~\$2,540.30~~ **\$3,810.45** to Purchase Refurbished Touch Screen Voting Units for the City's Two Precincts. City Manager/City Clerk.

Memorandum 15-198 from City Clerk as backup.

Mayor Wythe opened the public hearing.

Rick Malley, city resident, was not able to vote since he is visually impaired. Although touch screens are not required in borough and city elections it is now being discussed at many

levels. He asked that Council support his right to vote by secret vote. Those are his rights as defined in the United States and Alaska State Constitutions.

Ginny Espenshade, city resident, referenced the low voter turnout rate. She is in favor of the ordinance if it means one more voter.

Mayor Wythe closed the public hearing.

Mayor Wythe called for a motion for the adoption of Ordinance 15-45 by reading of title only for second and final reading.

REYNOLDS/LEWIS - SO MOVED.

Mayor Wythe called for a motion to substitute Ordinance 15-45(S) for Ordinance 15-45.

ADERHOLD/REYNOLDS – SO MOVED.

There was no discussion.

VOTE: (amendment) YES. NON OBJECTION. UNANIMOUS CONSENT.

Motion carried.

Council commented on the poor voter turnout and Venezuela's high voter turnout. A way to increase voter turnout would be to tie voting to qualify for the Permanent Fund Dividend.

VOTE: (main motion as amended) YES. NON OBJECTION. UNANIMOUS CONSENT.

Motion carried.

ORDINANCE(S)

CITY MANAGER'S REPORT

- A. City Manager's Report
 - 1. Memorandum 15-206 from Port and Harbor Director, Re: Alaska Abandoned and Derelict Vessel Task Force Meeting.
 - 2. Memorandum 15-207 from Port and Harbor Director, Re: Cook Inlet Harbor Safety Committee November Meeting.

Proposition 1: Suspension of HART for 3 years

I want to express my gratitude for how everyone has handled a difficult budget process this year. The Mayor and Council demonstrated leadership and courage by proposing Proposition 1 and engaging in difficult revenue conversations with the public. Every Council member went above and beyond participating in educating the public, advertising the special election and talking to their friends and neighbors. The staff has maintained a positive attitude and exemplary work ethic during a time of budget uncertainty. With reduced staff and reduced budgets, Budget A has many cuts that will affect employees' day to day ability to do their jobs, yet staff has stepped up to the plate and is ready to take on the challenges of leaner times. The community has been engaged since this conversation began in July. They have come out in sunshine and snowstorms to share solutions, ideas and give input. They have written emails, participated in online surveys, stopped by my office and attended Council meetings. My faith and appreciation for this community is reinforced with every conversation I have with Council, staff, and the public. I know the work has just begun, but I also know we have a great team and community that is willing to put in the time and effort. Thank you.

Permanent Fund and Investment Policy

The Permanent Fund Committee reviews the permanent fund investment policies during their first meeting of every year. Ordinance 15-43 eliminates the full service broker contract with US Bank and disbands the committee. The investment policy for all City funds is lengthy and could be simplified. The City needs to make sure we are striking the right balance between safety and returns – keeping in mind that government money must be treated differently than other investments. I think with the shift in management of the Permanent Fund the timing is right for a thorough review of the City-wide investment policy. To facilitate that conversation, Finance Director Li will reach out to other municipalities and see what investment policies they have in place and best practices. One recommendation that was brought to us by Time Value Investments, who holds some bonds for the City of Homer, is to invest dollars the City is willing to take a higher risk with (like the Permanent Fund) in index funds that track the market. This will be one, among many, considerations. How involved would Council like to be in looking at the investment policy? Should we schedule a work session in February to get into details or would you like staff to bring forward an ordinance, at which time Council can decide if more hands-on work is warranted?

February 12, 2016 Due Date set for Condominium Natural Gas HSAD

Resolution 15-081(S) delegated authority to the City Manager to set a deadline for the condominium units in the Natural Gas HSAD. The court mandated that the deadline be no more than 90 days after court approval of the assessment roll, November 16. City code requires 60 days' notice before the assessment is due. I have set February 12, 2016 as the due date for the assessments. Statements will be mailed to condominium owners no later than December 11, 2015. Condominium owners all owe a different amount depending on how much their percentage of ownership is in the building. Owners can pay the balance off in full or a minimum of \$405.27 (principal plus interest). According to Resolution 15-081(S) interest will be applied beginning July 1, 2015.

3rd Quarter Sales Tax Returns Up Slightly

Good news - sales tax figures for 3rd quarter were up slightly from 2nd quarter (0.3%). Though this does not represent a significant increase in revenue, it does mean that the estimates we based the 2016 budget on are on track and we are not forced to make up a big hole. We will watch 4th quarter returns closely with hopes that they continue to improve.

Visits from the Attorney

I have been working with Birch Horton Bittner and Cherot on ways we can utilize their services to their maximum capacity. As part of our retainer, the firm has agreed to send an attorney to Homer once a month to meet with staff, participate in committee/commission meetings, and spend more face time in Homer. For example, Attorney Wells will spend all day Thursday with staff working on Lease Committee issues. I think this will be a good use of attorney time and that we will get a lot of value from it.

City Manager Koester reported on the Permanent Fund and the Investment Policy. Council would like to review the Investment Policy to ensure it has the right balance of risk and safety. A Worksession will be scheduled in February.

There have been problems associated with people camping at Seafarer's Memorial. Currently camping is allowed there when all other city camping is closed. A solution to the problem is to open up the campground next to Pier One and charge camping fees with a 14-day maximum stay. An ordinance will be brought forward to fix that element of city code. First it will go through the Port and Harbor Advisory Commission.

Assistant City Manager Patrick Lawrence is leaving Homer to move closer to family. City Manager Koester will be deciding in the next week or so how her office will move forward.

B. Bid Report

CITY ATTORNEY REPORT

City Attorney Klinkner will provide a written report later in the month.

COMMITTEE REPORT

- A. Public Arts Committee
- B. Permanent Fund Committee
- C. Employee Committee Report

Matt Clarke, Deputy Harbormaster, reported on a recent meeting held on December 3rd with ten committee members present to review proposals of healthcare insurance plans. Brandon Nyberg of Wells Fargo Insurance Services advised the committee Premera and Assurant were the low cost proposers. While the committee was informed there would be a 16% or \$230,000 increase from 2015 rates, the City Manager's budget for 2016 contained a 10% increase. The Employee Committee endorsed elimination of hearing exams, limiting spinal manipulations to 12 per year, and switching providers for dental from Premera to Assurant. The changes yielded an 8.77% increase from 2015 rates or \$120,000; it falls \$18,000 under the amount proposed by the City Manager and offers a competitive insurance policy. The committee would like to keep the \$18,000 savings in the health insurance fund rather than putting it in the general fund in anticipation of rate increases in 2016. It is important the City Council understands employees are committed to the costs of health insurance. In 2013 the wellness program began and was administered through Virgin Health. Premera Blue Cross offers its own wellness program with a 5% reduction to 2017 rates if we achieve a minimum of 70% workforce participation. By law employers cannot require the wellness program. The committee proposes using a portion of the 5% to reincentivize the workforce. Not only will it decrease health care costs, it has a long term result of a strong workforce.

D. Public Safety Building Review Committee

Ken Castner, Chairman of the Public Safety Building Review Committee, reported on December 20th the committee will get three options back from the consultants for the new public safety facility. The options will be posted on the City's website. The committee will then start building information on the options and how viable citizens think they are. The committee will meet on January 6th and have a Worksession with Council on January 11th. By February it is hoped that the Council will adopt a procedure to move forward with one of the plans. Each plan had a budget target – low, medium, and full. The committee wanted the general contractor to come back and tell them what we would get with budgets at different levels.

E. Sustainable Animal Control Review Committee

PENDING BUSINESS

A. **Exclusion requests from the Homer Natural Gas Special Assessment District:**

1. Mary Mathes - KPB Parcel 17513222

Council reviewed the new information as provided by Planning. (See Resolution 15-108.)

NEW BUSINESS

RESOLUTIONS

A. **Resolution 15-104**, A Resolution of the City Council Certifying the Results of the City of Homer Special Election Held December 1, 2015 to Decide Proposition #1 “Shall the Dedication of 0.75% of the City Sales Tax to the Homer Accelerated Roads and Trails (H.A.R.T.) Program be Suspended for a Period of Three Years, to Make Such 0.75% of City Sales Tax Available for General Government Purposes?” City Clerk/Canvass Board.

Resolution 15-104(S), A Resolution of the City Council Certifying the Results of the City of Homer Special Election Held December 1, 2015 to Decide Proposition #1 “Shall the Dedication of 0.75% of the City Sales Tax to the Homer Accelerated Roads and Trails (H.A.R.T.) Program be Suspended for a Period of Three Years, to Make Such 0.75% of City Sales Tax Available for General Government Purposes?” City Clerk/Canvass Board.

Mayor Wythe called for a motion for the adoption of Resolution 15-104 by reading of title only.

ADERHOLD/LEWIS - SO MOVED.

Mayor Wythe called for a motion to substitute Resolution 15-104(S) for Resolution 15-104.

LEWIS/ADERHOLD - SO MOVED.

There was no discussion.

VOTE: (amendment) YES. NON OBJECTION. UNANIMOUS CONSENT.

Motion carried.

VOTE: (main motion as amended) YES. NON OBJECTION. UNANIMOUS CONSENT.

Motion carried.

B. **Resolution 15-106**, A Resolution of the City Council of Homer, Alaska, Approving a New Two Year Contract in the Amount of \$40,000 Per Year With Anderson Group, LLC for Legislative Consulting and Lobbying Services. City Manager.

Mayor Wythe called for a motion for the adoption of Resolution 15-106 by reading of title only.

LEWIS/REYNOLDS - SO MOVED.

Council discussed the option of amending the contract to one year and then putting it out for RFP.

Attorney Klinkner advised Council the lobbyist contract is subject to termination so they have that option already. The Council can reduce the contract to one year; it is not inconsistent with the terms of the contract.

VAN DYKE/SMITH - MOVED TO AMEND THIS CONTRACT TO A ONE YEAR TERM AS OPPOSED TO A TWO YEAR TERM AND REPLACE ANYTHING IN THE CONTRACT THAT ELUDES TO A TWO YEAR CONTRACT TO MAKE IT A ONE YEAR CONTRACT.

There was no additional discussion.

VOTE: (amendment) YES. VAN DYKE, SMITH, REYNOLDS, LEWIS

VOTE: NO. ZAK, ADERHOLD

Motion carried.

VOTE: (main motion as amended) YES. NON OBJECTION. UNANIMOUS CONSENT.

Motion carried.

C. **Resolution 15-108**, A Resolution of the Homer City Council Excluding Certain Properties Not Receiving a Benefit from the Homer Natural Gas Special Assessment District. City Clerk.

Memorandum 15-199 from City Clerk as backup.

Mayor Wythe called for a motion for the adoption of Resolution 15-108 by reading of title only.

LEWIS/REYNOLDS - SO MOVED.

REYNOLDS/LEWIS - MOVED TO AMEND LINE 28 TO INCLUDE KENAI PENINSULA BOROUGH PARCEL 17513222 (MARY MATHES).

There was no discussion.

VOTE: (amendment) YES. NON OBJECTION. UNANIMOUS CONSENT.

Motion carried.

VOTE: (main motion as amended) YES. NON OBJECTION. UNANIMOUS CONSENT.

Motion carried.

D. **Resolution 15-110**, A Resolution of the City Council of Homer, Alaska, Approving a New One-Year Contract With Premera Blue Cross. City Manager.

Resolution 15-110(S), A Resolution of the City Council of Homer, Alaska, Approving a New One-Year Contract With Premera Blue Cross and Assurant Health. City Manager.

Mayor Wythe called for a motion for the adoption of Resolution 15-110 by reading of title only.

ADERHOLD/REYNOLDS - SO MOVED.

Mayor Wythe called for a motion to substitute Resolution 15-110(S) for Resolution 15-110.

ADERHOLD/REYNOLDS – SO MOVED.

There was no discussion.

VOTE: (amendment) YES. NON OBJECTION. UNANIMOUS CONSENT.

Motion carried.

VOTE: (main motion as amended) YES. NON OBJECTION. UNANIMOUS CONSENT.

Motion carried.

E. **Resolution 15-111**, A Resolution of the City Council of Homer, Alaska, Requesting That the Alaska State Legislature Amend Alaska Statutes 29.45.0309(e) to Allow Local Municipalities to Determine the Value of Property Tax Exemption for Residents Over the Age of 65. Reynolds.

Mayor Wythe called for a motion for the adoption of Resolution 15-111 by reading of title only.

REYNOLDS/ADERHOLD – SO MOVED.

The resolution was brought forward to allow local municipalities to set their own limit for the senior tax exemption. With the increasing percentage of population over age 65 it is unsustainable for the full exemption. Property exemptions can be evaluated on need instead of age.

VOTE: YES. NON OBJECTION. UNANIMOUS CONSENT.

Motion carried.

F. **Resolution 15-109**, A Resolution of the Homer City Council to Support the Repair and Reopening of Rocky River State of Alaska Road Easement to the Gulf of Alaska. Mayor.

Mayor Wythe called for a motion for the adoption of Resolution 15-109 by reading of title only.

LEWIS/REYNOLDS - SO MOVED.

Mayor Wythe brought the resolution forward as a courtesy to the surrounding areas. Council expressed reservation with no backup. More information on who will build the road, the type of road, and the intent is needed.

LEWIS/REYNOLDS – MOVED TO POSTPONE TO OUR FIRST JANUARY MEETING WITH THE HOPES THE MAYOR CAN CONTACT HER COUNTERPART AND FIND OUT MORE.

Mayor Wythe agreed to contact Seldovia constituents.

VOTE: YES. NON OBJECTION. UNANIMOUS CONSENT.

Motion carried.

COMMENTS OF THE AUDIENCE

Ken Castner, city resident, said it is troubling that the HART provisions are not being followed. Either take the process off the books or start following what it is. On the condominium natural gas assessments Council has chipped away at things and is sore about losing and the way the judge ruled on things.

Scott Adams, city resident, recently read the best place to retire in Alaska is Homer. Senior citizens age 65 have the privilege of the property tax exemption. He can see seniors that are hurting financially. He commented about being annexed and still has no city water or sewer. He questioned why Council had not renegotiated the lobbyist contract for a lesser rate.

Linda Anderson, Homer lobbyist, thanked Council for their vote and will work hard to gain their trust. She asked Council to consider legislative conference calls; the more contact the better. Written reports are stale by the time Council receives them.

COMMENTS OF THE CITY ATTORNEY

City Attorney Klinkner congratulated the newly elected council members.

COMMENTS OF THE CITY CLERK

City Clerk Johnson thanked everyone who helped in the three elections this year and wished all Happy Holidays.

COMMENTS OF THE CITY MANAGER

City Manager Koester thanked and congratulated Council for the heavy lifting of the budget process that started in July. She thanked the community for their participation. It is not over, but rather has just begun. It was an educating, enlightening, and enjoyable experience getting involved with the public. She plans to spend the rest of the week parenting instead of working.

COMMENTS OF THE MAYOR

Mayor Wythe agrees with Ken Castner that we must read the policy for HART funds. Tonight was the authorization for considering capital projects and considering the HART funds to pay for them. For the last six months Council has been considering the financial situation of the City. The meetings will continue, but approving the HART reauthorization buys us time. As we walk through the process she challenged the community to trust that the Council and Katie are attending to the business and considering all the alternatives. There may be things that come up that are not understandable, but sometimes to arrive at the resolution of reducing costs you have to spend money to improve the situation you are operating under. It doesn't always make sense to people. Not all dollars in the budget are equal and not all pockets of money are available for all purposes. She urged the public to be prepared to take different paths that have a better outcome for the community in the long run.

COMMENTS OF THE CITY COUNCIL

Councilmember Aderhold thanked everyone who came out and spent the entire long meeting. She appreciates everyone's input and feedback and the concern for where the City is going. On HART fund procedures she appreciates the comments from the community on whether we are following the process. We need to evaluate the process we have outlined. For the people who brought the projects forward, it took them a long time to bring them to Council. They first went before commissions and committees. We need to make sure the process is straightforward, logical, and clear. She appreciates Patrick's service to the City and wished him good luck. She wished everyone Happy Holidays.

Councilmember Reynolds thanked Patrick, who was instrumental in making the town halls and the budget happen. She thanked everyone here tonight and the public comments. She recently did a FOL at the high school to see what it might take to be on a city commission. The students had a lively conversation about beach policy. She thanked Mr. Welsh for sponsoring her. It would be good to clarify HART fund projects. The projects adopted tonight meet the criteria of health, safety, traffic flow, and connection of pathways. She wished all Happy Holidays and is glad we have a budget.

Councilmember Lewis thanked Patrick. The comment made here tonight was not done in the right way. When Mr. Castner mentioned the judge would like another whack at us it made it sound like the judge was not very unbiased in the gas line. It hit the wrong way that we might have not gotten a fair shake.

Councilmember Smith commented it is always not a good idea to tell a judge of that caliber that he is wrong. He thanked the committees and employees and the good work that they do. He said goodbye to Patrick and thanked him for being part of the community. He appreciates Dr. Sarah Spencer and the time she took. Heroin is something that is affecting families in a devastating manner. As a city we need to take some lead in helping alleviate, if not end it. Meth cut a wide and devastating swath through this city and they have found cheaper paths now. He congratulated and thanked Katie for the hard work on the budget. His promise to the citizens is that he will continue to look at things with a close eye and find ways to see if we can become leaner. He wished all a good night, Merry Christmas, and Happy Hanukkah.

Councilmember Van Dyke commented voting machines were good; more voters were better, especially if they get out and vote. He wished all a Merry Christmas and all a good night.

Councilmember Zak thanked the voters, the mayor, and the city manager for getting the word out for the special election approving the HART funds. Without the funds it would have been extremely difficult. We will have to live and operate in the budget. He will miss Patrick Lawrence, as he helped Councilmember Zak and participated on the EDC. He thanked EDC Chairman Pat Brown for his hard work and Matt Clarke for the healthcare report. It is on his radar to think about healthcare. Lastly he thanked the lobbyist for her hard work and Heath

and Donna for attending AML. It is important for Homer to be seen as participating. He thanked the City Clerk and wished everyone Happy Holidays.

ADJOURNMENT

There being no further business to come before the Council, Mayor Wythe adjourned the meeting at 9:16 p.m. The next Regular Meeting is Monday, January 11, 2016 at 6:00 p.m. and Committee of the Whole 5:00 p.m. All meetings scheduled to be held in the City Hall Cowles Council Chambers located at 491 E. Pioneer Avenue, Homer, Alaska.

JO JOHNSON, MMC, CITY CLERK

Approved: _____



City of Homer

www.cityofhomer-ak.gov

Office of the City Clerk

491 East Pioneer Avenue
Homer, Alaska 99603

clerk@cityofhomer-ak.gov

(p) 907-235-3130

(f) 907-235-3143

Memorandum 16-002

TO: MAYOR WYTHE AND HOMER CITY COUNCIL

FROM: MELISSA JACOBSEN, CMC, DEPUTY CITY CLERK

DATE: DECEMBER 31, 2015

SUBJECT: LIQUOR LICENSE RENEWALS FOR BPO ELKS LODGE #2127, KHARACTERS, AJ'S OLDTOWN STEAKHOUSE & TAVERN, CAPTAIN PATTIES FISH HOUSE, CAFÉ CUPS, FINN'S, LITTLE MERMAID, THE ALIBI, SALTY DAWG SALOON, DOWN EAST SALOON, PHO & THAI RESTAURANT, AND GROG SHOP EAST END

We have been notified by the ABC Board of an application for liquor license renewals in the City of Homer for the following:

Lic. #	Doing Business As	License Type	Licensee	Premises Address
367	BPO Elks Lodge #2127	Club	BPO Elks Lodge #2127	215 W. Jenny Way
1085	Kharacters	Beverage Dispensary	Wonderful, LLC	3851 Shelford
1252	AJ's Oldtown Steakhouse & Tavern	Beverage Dispensary	APS Investments, LLC	120 W. Bunnell
2673	Captain Patties Fish House	Restaurant/Eating Place- Seasonal	Captain Patties Fish House, Inc.	4241 Homer Spit Road #1
3210	Café Cups	Restaurant/Eating Place	Bivalves, Inc.	162 W. Pioneer
4164	Finn's	Restaurant/Eating Place- Seasonal	Finn's, LLC	4287 Homer Spit Road Unit #4
5256	Little Mermaid	Restaurant/Eating Place- Public Convenience Seasonal	Mary K and Evan J Vogl	4246 Homer Spit Road #4&6
98	The Alibi	Beverage Dispensary	Mix Rocks, LLC	453 E Pioneer
1002	Salty Dawg Saloon	Beverage Dispensary	Sdawg, Inc.	4380 Homer Spit Road
23000	Down East Saloon	Beverage Dispensary	Down East, Inc.	3125 East End Road
5173	Pho & Thai Restaurant	Restaurant/Eating Place- Public Convenience	Bunloeun Chin	342 Sterling Hwy. Ste 101
2301	Grog Shop East End	Package Store	MSA, Inc.	3125 East End Road

RECOMMENDATION: Voice non objection and approval for the liquor license renewals.

Fiscal Note: Revenues.



City of Homer

www.cityofhomer-ak.gov

Police Department

4060 Heath Street
Homer, Alaska 99603

police@cityofhomer-ak.gov

(p) 907-235-3150

(f) 907-235-3151

JAN - 5 2016

Memorandum

TO: MELISSA JACOBSEN, DEPUTY CITY CLERK
FROM: MARK ROBL, CHIEF OF POLICE 
DATE: January 4, 2016
SUBJECT: LIQUOR LICENSE RENEWAL GROG SHOP EAST END

We have no objection to the application for liquor license renewal in the City of Homer for the following:

Type: Package Store
Lic #: 23014
DBA Name: Grog Shop East End
Service Location: 3125 East End Rd.
Owner: MSA, Inc.
Mailing Address: 369 E. Pioneer Ave., Homer, AK 99603

Chief Mark Robl



City of Homer

www.cityofhomer-ak.gov

Office of the City Clerk

491 East Pioneer Avenue
Homer, Alaska 99603

clerk@cityofhomer-ak.gov

(p) 907-235-3130

(f) 907-235-3143

Memorandum

TO: MARK ROBL, POLICE CHIEF
FROM: MELISSA JACOBSEN, DEPUTY CITY CLERK
DATE: DECEMBER 28, 2015
SUBJECT: LIQUOR LICENSE RENEWAL GROG SHOP EAST END

We have been notified by the ABC Board of an application for liquor license renewal in the City of Homer for the following:

Type: Package Store
Lic #: 23014
DBA Name: Grog Shop East End
Service Location: 3125 East End Rd.
Owner: MSA, Inc.
Mailing Address: 369 E. Pioneer Ave., Homer, AK 99603

This matter is scheduled for the January 11, 2015 City Council meeting. Please respond with objections/non-objections to this liquor license renewal by **Wednesday, January 6, 2016**.

Thank you for your assistance.



THE STATE
of **ALASKA**

GOVERNOR BILL WALKER

Department of Commerce, Community,
and Economic Development

ALCOHOLIC BEVERAGE CONTROL BOARD

Sarah Daulton Oates
550 W 7th Avenue, Suite 1600
Anchorage, AK 99501
Phone: 907.269.0350
alcohol.licensing@alaska.gov

December 22, 2015

City of Homer

Attn: City Clerk

VIA Email: clerk@cityofhomer-ak.gov

Cc: joanne@borough.kenai.ak.us

jblankenship@borough.kenai.ak.us

kring@borough.kenai.ak.us

Re: Notice of 2016/2017 Liquor License Renewal Applications

Dear Clerk,

We have received a renewal application for each of the following licenses within your jurisdiction:

Lic. #	Doing Business As	License Type	Licensee	Premises Address
2301	Grog Shop East End	Package Store	MSA, Inc.	3125 E End Road

A local governing body as defined under AS 04.21.080(b)(18) may protest the approval of an application(s) pursuant to AS 04.11.480 by providing the board **and** the applicant with a clear and concise written statement of reasons in support of a protest within 60 days of receipt of this notice. If a protest is filed, the board will not approve the application unless it finds that the protest is arbitrary, capricious, and unreasonable. Instead, in accordance with AS 04.11.510(b), the board will notify the applicant that the application is denied for reasons stated in the protest. The applicant is entitled to an informal conference with either the director or the board and, if not satisfied by the informal conference, is entitled to a formal hearing in accordance with AS 44.62.330-44.62-630. **IF THE APPLICANT REQUESTS A HEARING, THE LOCAL GOVERNING BODY MUST ASSIST IN OR UNDERTAKE THE DEFENSE OF ITS PROTEST.**

Under AS 04.11.420(a), the board may not issue a license or permit for premises in a municipality where a zoning regulation or ordinance prohibits the sale or consumption of alcoholic beverages, unless a variance of the regulation or ordinance has been approved. Under AS 04.11.420(b) municipalities must inform the board of zoning regulations or ordinances which prohibit the sale or consumption of alcoholic beverages. If a municipal zoning regulation or ordinance prohibits the sale or consumption of alcoholic beverages at the

proposed premises and no variance of the regulation or ordinance has been approved, please notify our office and provide a certified copy of the regulation or ordinance if you have not previously done so.

Protest under AS 04.11.480 and the prohibition of sale or consumption of alcoholic beverages as required by zoning regulation or ordinance under AS 04.11.420(a) are two separate and distinct subjects. Please bear that in mind when responding to this notice.

AS 04.21.010(d), if applicable, requires the municipality to provide written notice to the appropriate community council(s).

If you wish to protest the application(s) referenced above, please do so in the prescribed manner and within the prescribed time. Please show proof of service upon the applicant. For additional information regarding local governing body protests, please refer to 3 AAC 304.145.

If you have any questions or concerns or require additional information, please feel free to contact our licensing unit at alcohol.licensing@alaska.gov.

Sincerely,



Sarah Daulton Oates

Records & Licensing Supervisor

sarah.oates@alaska.gov



City of Homer

www.cityofhomer-ak.gov

Office of the City Clerk

491 East Pioneer Avenue
Homer, Alaska 99603

DEC 16 2015

clerk@cityofhomer-ak.gov
(p) 907-235-3130
(f) 907-235-3143

Memorandum

TO: MELISSA JACOBSON, DEPUTY CITY CLERK

FROM: MARK ROBL, POLICE CHIEF *[Signature]*

DATE: DECEMBER 14, 2015

SUBJECT: LIQUOR LICENSE RENEWALS FOR BPO ELKS LODGE #2127, KHARACTERS, AJ'S
OLDTOWN STEAKHOUSE & TAVERN, CAPTAIN PATTIES FISH HOUSE, CAFÉ CUPS,
FINN'S, LITTLE MERMAID, THE ALIBI, SALTY DAWG SALOON, DOWN EAST SALOON, PHO
& THAI RESTAURANT

The Homer Police Department has no objection to the following liquor license renewals within the City of Homer.

Lic. #	Doing Business As	License Type	Licensee	Premises Address
367	BPO Elks Lodge #2127	Club	BPO Elks Lodge #2127	215 W. Jenny Way
1085	Kharacters	Beverage Dispensary	Wonderful, LLC	3851 Shelford
1252	AJ's Oldtown Steakhouse & Tavern	Beverage Dispensary	APS Investments, LLC	120 W. Bunnell
2673	Captain Patties Fish House	Restaurant/Eating Place- Seasonal	Captain Patties Fish House, Inc.	4241 Homer Spit Road #1
3210	Café Cups	Restaurant/Eating Place	Bivalves, Inc.	162 W. Pioneer
4164	Finn's	Restaurant/Eating Place- Seasonal	Finn's, LLC	4287 Homer Spit Road Unit #4
5256	Little Mermaid	Restaurant/Eating Place- Public Convenience Seasonal	Mary K and Evan J Vogl	4246 Homer Spit Road #4&6
98	The Alibi	Beverage Dispensary	Mix Rocks, LLC	453 E Pioneer
1002	Salty Dawg Saloon	Beverage Dispensary	Sdawg, Inc.	4380 Homer Spit Road
23000	Down East Saloon	Beverage Dispensary	Down East, Inc.	3125 East End Road
5173	Pho & Thai Restaurant	Restaurant/Eating Place- Public Convenience	Bunloeun Chin	342 Sterling Hwy. Ste 101



City of Homer

www.cityofhomer-ak.gov

Office of the City Clerk

491 East Pioneer Avenue
Homer, Alaska 99603

clerk@cityofhomer-ak.gov

(p) 907-235-3130

(f) 907-235-3143

Memorandum

TO: MARK ROBL, POLICE CHIEF

FROM: MELISSA JACOBSEN, DEPUTY CITY CLERK

DATE: DECEMBER 14, 2015

SUBJECT: LIQUOR LICENSE RENEWALS FOR BPO ELKS LODGE #2127, KHARACTERS, AJ'S OLDTOWN STEAKHOUSE & TAVERN, CAPTAIN PATTIES FISH HOUSE, CAFÉ CUPS, FINN'S, LITTLE MERMAID, THE ALIBI, SALTY DAWG SALOON, DOWN EAST SALOON, PHO & THAI RESTAURANT

We have been notified by the ABC Board of an application for liquor license renewals in the City of Homer for the following:

Lic. #	Doing Business As	License Type	Licensee	Premises Address
367	BPO Elks Lodge #2127	Club	BPO Elks Lodge #2127	215 W. Jenny Way
1085	Kharacters	Beverage Dispensary	Wonderful, LLC	3851 Shelford
1252	AJ's Oldtown Steakhouse & Tavern	Beverage Dispensary	APS Investments, LLC	120 W. Bunnell
2673	Captain Patties Fish House	Restaurant/Eating Place- Seasonal	Captain Patties Fish House, Inc.	4241 Homer Spit Road #1
3210	Café Cups	Restaurant/Eating Place	Bivalves, Inc.	162 W. Pioneer
4164	Finn's	Restaurant/Eating Place- Seasonal	Finn's, LLC	4287 Homer Spit Road Unit #4
5256	Little Mermaid	Restaurant/Eating Place- Public Convenience Seasonal	Mary K and Evan J Vogl	4246 Homer Spit Road #4&6
98	The Alibi	Beverage Dispensary	Mix Rocks, LLC	453 E Pioneer
1002	Salty Dawg Saloon	Beverage Dispensary	Sdawg, Inc.	4380 Homer Spit Road
23000	Down East Saloon	Beverage Dispensary	Down East, Inc.	3125 East End Road
5173	Pho & Thai Restaurant	Restaurant/Eating Place- Public Convenience	Bunloeun Chin	342 Sterling Hwy. Ste 101

This matter is scheduled for the January 11, 2016 City Council meeting. Please respond with objections/non-objections to these liquor license renewals by **Wednesday, January 6, 2016**.

Thank you for your assistance.



THE STATE
of **ALASKA**

GOVERNOR BILL WALKER

Department of Commerce, Community,
and Economic Development

ALCOHOLIC BEVERAGE CONTROL BOARD

Sarah Daulton Oates
550 W 7th Avenue, Suite 1600
Anchorage, AK 99501
Phone: 907.269.0350
alcohol.licensing@alaska.gov

DEC 14 2015

December 11, 2015

City of Homer

Attn: City Clerk

VIA Email: clerk@cityofhomer-ak.gov

Cc: joanne@borough.kenai.ak.us

jblankenship@borough.kenai.ak.us

kring@borough.kenai.ak.us

Re: Notice of 2016/2017 Liquor License Renewal Applications

Dear Clerk,

We have received a renewal application for each of the following licenses within your jurisdiction:

Lic. #	Doing Business As	License Type	Licensee	Premises Address
367	BPO Elks Lodge #2127	Club	BPO Elks Lodge #2127	215 W Jenny Way
1085	Kharacters	Beverage Dispensary	Wonderful, LLC	3851 Shelford
1252	AJ's Oldtown Steakhouse & Tavern	Beverage Dispensary	APS Investments, LLC	120 W Bunnel Avenue
2673	Captain Patties Fish House	Restaurant/Eating Place-Seasonal	Captain Ptties Fish House, Inc.	4241 Homer Spit Road #1
3210	Café Cups	Restaurant/Eating Place	Bivalves, Inc.	162 W Pioneer Avenue
4164	Finn's	Restaurant/Eating Place-Seasonal	Finn's, LLC	4287 Homer Spit Road, Unit #4
5256	Little Mermaid	Restaurant/Eating Place-Public Convenience Seasonal	Mary K and Evan J Vogl	4246 Homer Spit Road #4 & 6

A local governing body as defined under AS 04.21.080(b)(18) may protest the approval of an application(s) pursuant to AS 04.11.480 by providing the board **and** the applicant with a clear and concise written statement of reasons in support of a protest within 60 days of receipt of this notice. If a protest is filed, the board will not approve the application unless it finds that the protest is arbitrary, capricious, and unreasonable. Instead, in accordance with AS 04.11.510(b),

the board will notify the applicant that the application is denied for reasons stated in the protest. The applicant is entitled to an informal conference with either the director or the board and, if not satisfied by the informal conference, is entitled to a formal hearing in accordance with AS 44.62.330-44.62-630. **IF THE APPLICANT REQUESTS A HEARING, THE LOCAL GOVERNING BODY MUST ASSIST IN OR UNDERTAKE THE DEFENSE OF ITS PROTEST.**

Under AS 04.11.420(a), the board may not issue a license or permit for premises in a municipality where a zoning regulation or ordinance prohibits the sale or consumption of alcoholic beverages, unless a variance of the regulation or ordinance has been approved. Under AS 04.11.420(b) municipalities must inform the board of zoning regulations or ordinances which prohibit the sale or consumption of alcoholic beverages. If a municipal zoning regulation or ordinance prohibits the sale or consumption of alcoholic beverages at the proposed premises and no variance of the regulation or ordinance has been approved, please notify our office and provide a certified copy of the regulation or ordinance if you have not previously done so.

Protest under AS 04.11.480 and the prohibition of sale or consumption of alcoholic beverages as required by zoning regulation or ordinance under AS 04.11.420(a) are two separate and distinct subjects. Please bear that in mind when responding to this notice.

AS 04.21.010(d), if applicable, requires the municipality to provide written notice to the appropriate community council(s).

If you wish to protest the application(s) referenced above, please do so in the prescribed manner and within the prescribed time. Please show proof of service upon the applicant. For additional information regarding local governing body protests, please refer to 3 AAC 304.145.

If you have any questions or concerns or require additional information, please feel free to contact our licensing unit at alcohol.licensing@alaska.gov.

Sincerely,



Sarah Daulton Oates

Records & Licensing Supervisor

sarah.oates@alaska.gov

13(a)

Alcoholic Beverage Control Board 550 W 7 th Avenue, Suite 1600 Anchorage, AK 99501	Renewal Liquor License 2016/2017	Phone: (907) 269-0350 Email: alcohol.licensing@alaska.gov http://commerce.alaska.gov/web/abc/Home.aspx
---	---	---

License is: Full Year OR Seasonal If seasonal, list dates of operation: _____

SECTION A - LICENSE INFORMATION		
License Number: 367	License Type: Club	Statute Reference: Sec. 04.11. 110
Local Governing Body: Homer Kenai Peninsula Borough	Community Council (if applicable):	
Name of Licensee: BPO Elks Lodge #2127	Doing Business As (DBA): BPO Elks Lodge #2127	
Mailing Address: 215 W Jenny Way Homer, AK 99603	Street Address or Location of Premises: 215 W Jenny Way Homer, AK 99603	
Phone: 907-235-2127	Fax: 907-235-2190	Email: homerefk@pci.net

SECTION B - OWNERSHIP INFORMATION - CORPORATION (If owner is a sole proprietor, skip to SECTION C)				
<i>Corporations, LLCs, LLPs and LPs must be registered with the Alaska Division of Corporations.</i>				
Name of Entity (Corporation/LLC/LLP/LP): BPO Elks Lodge #2127				
Is the Entity in "Good Standing" with the Alaska Division of Corporations? <input checked="" type="checkbox"/> Yes <input type="checkbox"/> No If no, attach written explanation Your entity <i>must</i> be in compliance with Title 10 of the Alaska Statutes to be a valid liquor licensee.				
Entity Members (Must include President, Secretary, Treasurer, Vice-President, Manager and Shareholder/Member with 10% or more of stock)				
Name	Title	%	Mailing Address	Telephone Number
Justin Cole <i>JCS</i>	Pres.		33730 Justin Ct., Homer, AK 99603	907-226-3444
Jan Jonker (Mr.)	Sec.		422 Elderberry Ct., Homer, AK 99603	907-435-7652
Michael Riley	Treas.		POB 502, Homer, AK 99603	907-399-7808
Tom Strouzas <i>JCS</i>	Vice Pres.		POB 1481 Homer, AK 99603	907-235-3677
NOTE: If you need additional space, please attach a separate sheet.				

SECTION C – OWNERSHIP INFORMATION – SOLE PROPRIETORSHIP (INDIVIDUAL OWNER & SPOUSE)			
Individual Licensees/Affiliates (The ABC Board defines an "affiliate" as the spouse or significant other of a licensee. Each affiliate must be listed.)			
Name:	Applicant <input type="checkbox"/>	Name:	Applicant <input type="checkbox"/>
Address:	Affiliate <input type="checkbox"/>	Address:	Affiliate <input type="checkbox"/>
Phone:	Date of Birth:	Phone:	Date of Birth:
Name:	Applicant <input type="checkbox"/>	Name:	Applicant <input type="checkbox"/>
Address:	Affiliate <input type="checkbox"/>	Address:	Affiliate <input type="checkbox"/>
Phone:	Date of Birth:	Phone:	Date of Birth:

SECTION D – SUPPLEMENTAL QUESTIONS	
Was your business open at least 30 days for 8 hours each day in 2014?	<input checked="" type="checkbox"/> Yes <input type="checkbox"/> No
Was your business open at least 30 days for 8 hours each day in 2015?	<input checked="" type="checkbox"/> Yes <input type="checkbox"/> No
Has any person named in this application been convicted of a felony or Title 4 violation? If yes, attach a written explanation.	<input type="checkbox"/> Yes <input checked="" type="checkbox"/> No
Has the licensed premises changed from the last diagram submitted? If yes, attach a new diagram with designated premises areas outlined in red.	<input type="checkbox"/> Yes <input checked="" type="checkbox"/> No
For Package Stores only:	
Do you intend to sell alcoholic beverages in response to a written order? N/A	<input type="checkbox"/> Yes <input type="checkbox"/> No
For Restaurant / Eating Places only: N/A	
Were your gross receipts from the sale of food at least 50% of your total gross receipts for 2014 and 2015?	<input type="checkbox"/> Yes <input type="checkbox"/> No

DECLARATION
<ul style="list-style-type: none"> I declare under penalty of perjury that I have examined this application, including the accompanying schedules and statements, and to the best of my knowledge and belief it is true, correct, and complete. I hereby certify that there have been no changes in officers or stockholders that have not been reported to the Alcoholic Beverage Control Board. The undersigned certifies on behalf of the organized entity, it is understood that a misrepresentation of fact is cause for rejection of this application or revocation of any license issued. I further certify that I have read and am familiar with Title 4 of the Alaska statutes and its regulations, and that in accordance with AS 04.11.450, no person other than the licensee(s) has any direct or indirect financial interest in the licensed business. I agree to provide all information required by the Alcoholic Beverage Control Board in support of this application. As a licensee (sole proprietor or partner), I certify that I have received Alaska alcohol server training and my certification is currently valid. As a corporate/LLC licensee, I certify that all agents and employees who serve, sell, or are otherwise responsible for the service, sale, or storage of alcoholic beverages have received Alaska alcohol server training and their certification is currently valid. I further certify that certain shareholders, officers, directors, or members of the entity who are not directly or indirectly responsible for the service, sale, or storage of alcoholic beverages are not Alaska alcohol server training certified and will not be required to be certified. As a licensee, I certify that all of my agents and employees tasked with patron identification verification have received alcohol server training and their certification is currently valid.

License Fee	\$ 1200.00
Filing Fee	\$ 200.00
TOTAL	\$ 1400.00
Late Fee of \$500.00 – if received or postmarked after 12/31/2015	\$
Fingerprint Fee – \$49.75 per person (only for new owners/members)	\$
GRAND TOTAL	\$

Licensee Signature <i>Jan C. Jonker (MR)</i>	Printed Name & Title: JAN C. JONKER, SECRETARY
Notary Signature <i>Mardene R. Hodgdon</i>	Subscribed and sworn to before me this 3 day of December, 2015.
Notary Public in and for the State of Alaska	My commission expires: 10/27/17

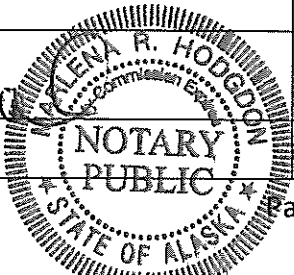

13033

Alcoholic Beverage Control Board
550 W 7th Avenue, Suite 1600
Anchorage, AK 99501

Renewal Liquor License 2016/2017

Phone: (907) 269-0350
Email: alcohol.licensing@alaska.gov
<http://commerce.alaska.gov/web/abc/Home.aspx>

License is: Full Year OR Seasonal If seasonal, list dates of operation: _____

SECTION A - LICENSE INFORMATION		
License Number: 1085	License Type: Beverage Dispensary	Statute Reference: Sec. 04.11.090
Local Governing Body: Homer Kenai Peninsula Borough	Community Council (if applicable):	
Name of Licensee: Wonderful LLC	Doing Business As (DBA): Kharacters	
Mailing Address: 1154 Rueith way Homer AK 99603	Street Address or Location of Premises: 3851 Shelford	
Phone: 907-285-1455	Fax:	Email: Rondy.roo@hotmail.com

SECTION B – OWNERSHIP INFORMATION – CORPORATION (if owner is a sole proprietor, skip to SECTION C)				
<i>Corporations, LLCs, LLPs and LPs must be registered with the Alaska Division of Corporations.</i>				
Name of Entity (Corporation/LLC/LLP/LP): Wonderful LLC				
Is the Entity in "Good Standing" with the Alaska Division of Corporations? <input checked="" type="checkbox"/> Yes <input type="checkbox"/> No If no, attach written explanation. Your entity <i>must</i> be in compliance with Title 10 of the Alaska Statutes to be a valid liquor licensee.				
Entity Members (Must include President, Secretary, Treasurer, Vice-President, Manager and Shareholder/Member with 10% or more of stock)				
Name	Title	%	Mailing Address	Telephone Number
Randy Matthews	President	50		907-299-3579
Kelly Matthews	Secretary	50		907-299-3350
NOTE: If you need additional space, please attach a separate sheet.				

SECTION C – OWNERSHIP INFORMATION – SOLE PROPRIETORSHIP (INDIVIDUAL OWNER & SPOUSE)

Individual Licensees/Affiliates (The ABC Board defines an "affiliate" as the spouse or significant other of a licensee. Each affiliate must be listed.)

Name: Address: Phone:	Applicant <input type="checkbox"/> Affiliate <input type="checkbox"/> Date of Birth:	Name: Address: Phone:	Applicant <input type="checkbox"/> Affiliate <input type="checkbox"/> Date of Birth:
N/A			
Name: Address: Phone:	Applicant <input type="checkbox"/> Affiliate <input type="checkbox"/> Date of Birth:	Name: Address: Phone:	Applicant <input type="checkbox"/> Affiliate <input type="checkbox"/> Date of Birth:

SECTION D – SUPPLEMENTAL QUESTIONS

Was your business open at least 30 days for 8 hours each day in 2014? Yes No

Was your business open at least 30 days for 8 hours each day in 2015? Yes No

Has any person named in this application been convicted of a felony or Title 4 violation? Yes No
If yes, attach a written explanation.

Has the licensed premises changed from the last diagram submitted? Yes No
If yes, attach a new diagram with designated premises areas outlined in red.

DECLARATION

- I declare under penalty of perjury that I have examined this application, including the accompanying schedules and statements, and to the best of my knowledge and belief it is true, correct, and complete.
- I hereby certify that there have been no changes in officers or stockholders that have not been reported to the Alcoholic Beverage Control Board. The undersigned certifies on behalf of the organized entity, it is understood that a misrepresentation of fact is cause for rejection of this application or revocation of any license issued.
- I further certify that I have read and am familiar with Title 4 of the Alaska statutes and its regulations, and that in accordance with AS 04.11.450, no person other than the licensee(s) has any direct or indirect financial interest in the licensed business.
- I agree to provide all information required by the Alcoholic Beverage Control Board in support of this application.
- As a licensee (sole proprietor or partner), I certify that I have received Alaska alcohol server training and my certification is currently valid.
- As a corporate/LLC licensee, I certify that all agents and employees who serve, sell, or are otherwise responsible for the service, sale, or storage of alcoholic beverages have received Alaska alcohol server training and their certification is currently valid. I further certify that certain shareholders, officers, directors, or members of the entity who are not directly or indirectly responsible for the service, sale, or storage of alcoholic beverages are not Alaska alcohol server training certified and will not be required to be certified.
- As a licensee, I certify that all of my agents and employees tasked with patron identification verification have received alcohol server training and their certification is currently valid.

License Fee	\$ 2500.00
Filing Fee	\$ 200.00
TOTAL	\$ 2700.00
Late Fee of \$500.00 – if received or postmarked after 12/31/2015	\$
Fingerprint Fee – \$49.75 per person (only for new owners/members)	\$
GRAND TOTAL	\$ 2700.00

Licensee signature 	Printed Name & Title: Randy Matthews President
Notary Signature 	Subscribed and sworn to before me this 17 th day of Nov, 2015.
Notary Public in and for the state of: KPB - Homer Alaska	My commission expires: Feb 8, 2018

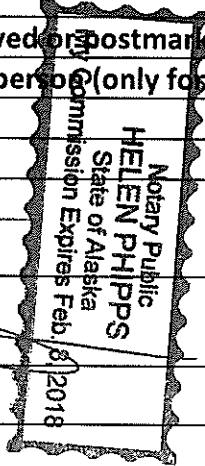

13178

Alcoholic Beverage Control Board
550 W 7th Avenue, Suite 1600
Anchorage, AK 99501

**Renewal Liquor License
2016/2017**

Phone: (907) 269-0350
Email: alcohol.licensing@alaska.gov
<http://commerce.alaska.gov/web/abc/Home.aspx>

License is: Full Year OR Seasonal If seasonal, list dates of operation: _____

SECTION A - LICENSE INFORMATION		
License Number: 1252	License Type: Beverage Dispensary	Statute Reference: Sec. 04.11.090
Local Governing Body: Homer Kenai Peninsula Borough	Community Council (if applicable):	
Name of Licensee: APS Investments, LLC	Doing Business As (DBA): AJ's Oldtown Steakhouse & Tavern	
Mailing Address: 135 W. Bunnell Ave Homer	Street Address or Location of Premises: 120 W Bunnell Avenue	
Phone: 907-299-8019	Fax:	Email: adriennewalli@hotmail.com

SECTION B – OWNERSHIP INFORMATION – CORPORATION (if owner is a sole proprietor, skip to SECTION C)				
Corporations, LLCs, LLPs and LPs must be registered with the Alaska Division of Corporations.				
Name of Entity (Corporation/LLC/LLP/LP): APS Investments, LLC				
Is the Entity in "Good Standing" with the Alaska Division of Corporations? <input checked="" type="checkbox"/> Yes <input type="checkbox"/> No If no, attach written explanation. Your entity <i>must</i> be in compliance with Title 10 of the Alaska Statutes to be a valid liquor licensee.				
Entity Members (Must include President, Secretary, Treasurer, Vice-President, Manager and Shareholder/Member with 10% or more of stock)				
Name	Title	%	Mailing Address	Telephone Number
Adrenne Sweeney	Manager	49%	135 W. Bunnell Ave Homer AK	907-299-8019
Alexander Sweeney	Member	51%	135 W Bunnell Homer AK	907-317-4582
NOTE: If you need additional space, please attach a separate sheet.				

SECTION C – OWNERSHIP INFORMATION – SOLE PROPRIETORSHIP (INDIVIDUAL OWNER & SPOUSE)

Individual Licensees/Affiliates (The ABC Board defines an "affiliate" as the spouse or significant other of a licensee. Each affiliate must be listed.)

Name: <i>Adrienne Sweeney</i>	Applicant <input checked="" type="checkbox"/> Affiliate <input type="checkbox"/>	Name:	Applicant <input type="checkbox"/> Affiliate <input type="checkbox"/>
Address: <i>135 W. Bunnell Ave Homer AK 99603</i>	Date of Birth: <i>2-13-70</i>	Address:	Date of Birth:
Phone: <i>907-299-8019</i>		Phone:	
Name: <i>Alexander Sweeney</i>	Applicant <input checked="" type="checkbox"/> Affiliate <input type="checkbox"/>	Name:	Applicant <input type="checkbox"/> Affiliate <input type="checkbox"/>
Address: <i>same as above</i>	Date of Birth: <i>3-3-51</i>	Address:	Date of Birth:
Phone: <i>907-317-6582</i>		Phone:	

SECTION D – SUPPLEMENTAL QUESTIONS

Was your business open at least 30 days for 8 hours each day in 2014? Yes No

Was your business open at least 30 days for 8 hours each day in 2015? Yes No

Has any person named in this application been convicted of a felony or Title 4 violation?
If yes, attach a written explanation. Yes No

Has the licensed premises changed from the last diagram submitted?
If yes, attach a new diagram with designated premises areas outlined in red. Yes No

DECLARATION

- I declare under penalty of perjury that I have examined this application, including the accompanying schedules and statements, and to the best of my knowledge and belief it is true, correct, and complete.
- I hereby certify that there have been no changes in officers or stockholders that have not been reported to the Alcoholic Beverage Control Board. The undersigned certifies on behalf of the organized entity, it is understood that a misrepresentation of fact is cause for rejection of this application or revocation of any license issued.
- I further certify that I have read and am familiar with Title 4 of the Alaska statutes and its regulations, and that in accordance with AS 04.11.450, no person other than the licensee(s) has any direct or indirect financial interest in the licensed business.
- I agree to provide all information required by the Alcoholic Beverage Control Board in support of this application.
- As a licensee (sole proprietor or partner), I certify that I have received Alaska alcohol server training and my certification is currently valid.
- As a corporate/LLC licensee, I certify that all agents and employees who serve, sell, or are otherwise responsible for the service, sale, or storage of alcoholic beverages have received Alaska alcohol server training and their certification is currently valid. I further certify that certain shareholders, officers, directors, or members of the entity who are not directly or indirectly responsible for the service, sale, or storage of alcoholic beverages are not Alaska alcohol server training certified and will not be required to be certified.
- As a licensee, I certify that all of my agents and employees tasked with patron identification verification have received alcohol server training and their certification is currently valid.

License Fee	\$ 2500.00
Filing Fee	\$ 200.00
TOTAL	\$ 2700.00
Late Fee of \$500.00 – if received or postmarked after 12/31/2015	\$
Fingerprint Fee – \$49.75 per person (only for new owners/members)	\$
GRAND TOTAL	\$2700⁰⁰

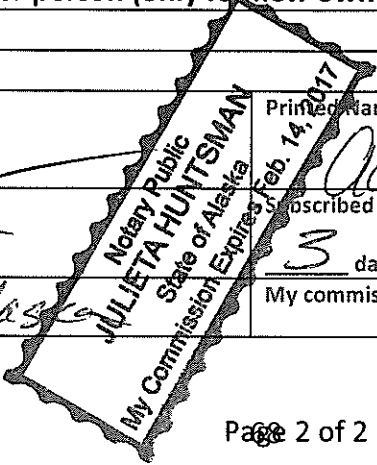
Licensee Signature <i>Adrienne Sweeney</i>		Printed Name & Title: <i>Adrienne Sweeney - Manager</i>
Notary Signature <i>[Signature]</i>		Subscribed and sworn to before me this <i>3</i> day of <i>December, 2015.</i>
Notary Public in and for the State of: <i>Alaska</i>		My commission expires: <i>2-14-17</i>

Alcoholic Beverage Control Board
 550 W 7th Avenue, Suite 1600
 Anchorage, AK 99501

Renewal Liquor License 2016/2017

Phone: (907) 269-0350
 Email: alcohol.licensing@alaska.gov
<http://commerce.alaska.gov/web/abc/Home.aspx>

License is: Full Year OR Seasonal If seasonal, list dates of operation: 4/1 - 9/31

SECTION A - LICENSE INFORMATION		
License Number: 2673	License Type: Restaurant/Eating Place-Seasonal	Statute Reference: Sec. 04.11.100
Local Governing Body: Homer Kenai Peninsula Borough		Community Council (if applicable):
Name of Licensee: Captain Patties Fish House, Inc.		Doing Business As (DBA): Captain Patties Fish House
Mailing Address: PO Box 210 Anchorage Pt. AK 99556		Street Address or Location of Premises: 4241 Homer Spit Road #1
Phone: 907-235-8318	Fax: 907-235-7885	Email: Silverm@ptiakalaska.net

SECTION B – OWNERSHIP INFORMATION – CORPORATION (if owner is a sole proprietor, skip to SECTION C)				
Corporations, LLCs, LLPs and LPs must be registered with the Alaska Division of Corporations.				
Name of Entity (Corporation/LLC/LLP/LP): Captain Patties Fish House, Inc.				
Is the Entity in "Good Standing" with the Alaska Division of Corporations? <input checked="" type="checkbox"/> Yes <input type="checkbox"/> No If no, attach written explanation. Your entity <i>must</i> be in compliance with Title 10 of the Alaska Statutes to be a valid liquor licensee.				
Entity Members (Must include President, Secretary, Treasurer, Vice-President, Manager and Shareholder/Member with 10% or more of stock)				
Name	Title	%	Mailing Address	Telephone Number
Patty Hensley	Pres	100	PO Box 210 AP. AK 99556	235-8318
John Michels	Sec/Treas		Same	Same
NOTE: if you need additional space, please attach a separate sheet.				

SECTION C – OWNERSHIP INFORMATION – SOLE PROPRIETORSHIP (INDIVIDUAL OWNER & SPOUSE)

Individual Licensees/Affiliates (The ABC Board defines an "affiliate" as the spouse or significant other of a licensee. Each affiliate must be listed.)

Name:	Applicant <input type="checkbox"/>	Name:	Applicant <input type="checkbox"/>
Address:	Affiliate <input type="checkbox"/>	Address:	Affiliate <input type="checkbox"/>
Phone:	Date of Birth:	Phone:	Date of Birth:
Name:	Applicant <input type="checkbox"/>	Name:	Applicant <input type="checkbox"/>
Address:	Affiliate <input type="checkbox"/>	Address:	Affiliate <input type="checkbox"/>
Phone:	Date of Birth:	Phone:	Date of Birth:

SECTION D – SUPPLEMENTAL QUESTIONS

Was your business open at least 30 days for 8 hours each day in 2014? Yes No

Was your business open at least 30 days for 8 hours each day in 2015? Yes No

Has any person named in this application been convicted of a felony or Title 4 violation?
If yes, attach a written explanation. Yes No

Has the licensed premises changed from the last diagram submitted?
If yes, attach a new diagram with designated premises areas outlined in red. Yes No

Were your gross receipts from the sale of food at least 50% of your total gross receipts for 2014 and 2015? Yes No

DECLARATION

- I declare under penalty of perjury that I have examined this application, including the accompanying schedules and statements, and to the best of my knowledge and belief it is true, correct, and complete.
- I hereby certify that there have been no changes in officers or stockholders that have not been reported to the Alcoholic Beverage Control Board. The undersigned certifies on behalf of the organized entity, it is understood that a misrepresentation of fact is cause for rejection of this application or revocation of any license issued.
- I further certify that I have read and am familiar with Title 4 of the Alaska statutes and its regulations, and that in accordance with AS 04.11.450, no person other than the licensee(s) has any direct or indirect financial interest in the licensed business.
- I agree to provide all information required by the Alcoholic Beverage Control Board in support of this application.
- As a licensee (sole proprietor or partner), I certify that I have received Alaska alcohol server training and my certification is currently valid.
- As a corporate/LLC licensee, I certify that all agents and employees who serve, sell, or are otherwise responsible for the service, sale, or storage of alcoholic beverages have received Alaska alcohol server training and their certification is currently valid. I further certify that certain shareholders, officers, directors, or members of the entity who are not directly or indirectly responsible for the service, sale, or storage of alcoholic beverages are not Alaska alcohol server training certified and will not be required to be certified.
- As a licensee, I certify that all of my agents and employees tasked with patron identification verification have received alcohol server training and their certification is currently valid.

License Fee	\$ 300.00
Filing Fee	\$ 200.00
TOTAL	\$ 500.00
Late Fee of \$500.00 – if received or postmarked after 12/31/2015	\$
Fingerprint Fee – \$49.75 per person (only for new owners/members)	\$
GRAND TOTAL	\$ 500.00

13032 ✓

Licensee Signature <i>Patty Hensley</i>	Notary Public DOROTHY J. FLINT State of Alaska My Commission Expires Jan 17, 2017	Printed Name & Title: Patty Hensley Pres.
Notary Signature <i>Dorothy J. Flint</i>		Subscribed and sworn to before me this 17 th day of November, 2015.
Notary Public in and for the State of: Anchor Point, AK 99556		My commission expires: Jan 17, 2017

13103

Alcoholic Beverage Control Board 550 W 7 th Avenue, Suite 1600 Anchorage, AK 99501	Renewal Liquor License 2016/2017	Phone: (907) 269-0350 Email: alcohol.licensing@alaska.gov http://commerce.alaska.gov/web/abc/Home.aspx
---	---	---

License is: Full Year OR Seasonal If seasonal, list dates of operation: _____

SECTION A - LICENSE INFORMATION		
License Number: 3210	License Type: Restaurant/Eating Place	Statute Reference: Sec. 04.11.100
Local Governing Body: Homer Kenai Peninsula Borough		Community Council (if applicable):
Name of Licensee: Bivalves Inc		Doing Business As (DBA): Café Cups
Mailing Address: 162 W. Pioneer Ave. Homer AK 99663		Street Address or Location of Premises: 162 W Pioneer Avenue
Phone: 907-235-8330	Fax: SAME	Email:

SECTION B – OWNERSHIP INFORMATION – CORPORATION (if owner is a sole proprietor, skip to SECTION C)				
<i>Corporations, LLCs, LLPs and LPs must be registered with the Alaska Division of Corporations.</i>				
Name of Entity (Corporation/LLC/LLP/LP): Bivalves Inc				
Is the Entity in "Good Standing" with the Alaska Division of Corporations? <input type="checkbox"/> Yes <input type="checkbox"/> No If no, attach written explanation. Your entity <i>must</i> be in compliance with Title 10 of the Alaska Statutes to be a valid liquor licensee.				
Entity Members (Must include President, Secretary, Treasurer, Vice-President, Manager and Shareholder/Member with 10% or more of stock)				
Name	Title	%	Mailing Address	Telephone Number
DAVID OLSEN	PRES	50	162 W PIONEER AVE HOMER	907 235 8330
JENNIFER OLSEN	SEC	50	162 W PIONEER AVE HOMER	907 235 8330
NOTE: If you need additional space, please attach a separate sheet.				

SECTION C – OWNERSHIP INFORMATION – SOLE PROPRIETORSHIP (INDIVIDUAL OWNER & SPOUSE)

Individual Licensees/Affiliates (The ABC Board defines an "affiliate" as the spouse or significant other of a licensee. Each affiliate must be listed.)

Name: <u>DAVID OLSEN</u> Address: <u>162 W Pioneer</u> Phone: <u>Home AK 907 735 8330</u>	Applicant <input checked="" type="checkbox"/> Affiliate <input type="checkbox"/> Date of Birth: <u>10/31/56</u>	Name: Address: Phone:	Applicant <input type="checkbox"/> Affiliate <input type="checkbox"/> Date of Birth:
Name: <u>JENNIFER OLSEN</u> Address: <u>162 W Pioneer</u> Phone: <u>Home AK 907 735 8330</u>	Applicant <input checked="" type="checkbox"/> Affiliate <input type="checkbox"/> Date of Birth: <u>4/21/60</u>	Name: Address: Phone:	Applicant <input type="checkbox"/> Affiliate <input type="checkbox"/> Date of Birth:

SECTION D – SUPPLEMENTAL QUESTIONS

Was your business open at least 30 days for 8 hours each day in 2014? Yes No

Was your business open at least 30 days for 8 hours each day in 2015? Yes No

Has any person named in this application been convicted of a felony or Title 4 violation?
If yes, attach a written explanation. Yes No



Has the licensed premises changed from the last diagram submitted?
If yes, attach a new diagram with designated premises areas outlined in red. Yes No

Were your gross receipts from the sale of food at least 50% of your total gross receipts for 2014 and 2015? Yes No

DECLARATION

- I declare under penalty of perjury that I have examined this application, including the accompanying schedules and statements, and to the best of my knowledge and belief it is true, correct, and complete.
- I hereby certify that there have been no changes in officers or stockholders that have not been reported to the Alcoholic Beverage Control Board. The undersigned certifies on behalf of the organized entity, it is understood that a misrepresentation of fact is cause for rejection of this application or revocation of any license issued.
- I further certify that I have read and am familiar with Title 4 of the Alaska statutes and its regulations, and that in accordance with AS 04.11.450, no person other than the licensee(s) has any direct or indirect financial interest in the licensed business.
- I agree to provide all information required by the Alcoholic Beverage Control Board in support of this application.
- As a licensee (sole proprietor or partner), I certify that I have received Alaska alcohol server training and my certification is currently valid.
- As a corporate/LLC licensee, I certify that all agents and employees who serve, sell, or are otherwise responsible for the service, sale, or storage of alcoholic beverages have received Alaska alcohol server training and their certification is currently valid. I further certify that certain shareholders, officers, directors, or members of the entity who are not directly or indirectly responsible for the service, sale, or storage of alcoholic beverages are not Alaska alcohol server training certified and will not be required to be certified.
- As a licensee, I certify that all of my agents and employees tasked with patron identification verification have received alcohol server training and their certification is currently valid.

License Fee	\$ 600.00
Filing Fee	\$ 200.00
TOTAL	\$ 800.00
Late Fee of \$500.00 – if received or postmarked after 12/31/2015	\$
Fingerprint Fee – \$49.75 per person (only for new owners/members)	\$
GRAND TOTAL	\$ 800-

Licensee Signature 	Printed Name & Title: <u>JENNIFER OLSEN Secretary</u>
Notary Signature 	Subscribed and sworn to before me this <u>19</u> day of <u>October</u> , <u>2015</u>
Notary Public in and for the State of: <u>Alaska</u>	My commission expires: <u>1-11-2019</u>

13084

Alcoholic Beverage Control Board
550 W 7th Avenue, Suite 1600
Anchorage, AK 99501

**Renewal Liquor License
2016/2017**

Phone: (907) 269-0350
Email: alcohol.licensing@alaska.gov
<http://commerce.alaska.gov/web/abc/Home.aspx>

License is: Full Year OR Seasonal

If seasonal, list dates of operation: 5/1 - 10/1

SECTION A - LICENSE INFORMATION		
License Number: 4164	License Type: Restaurant/Eating Place-Seasonal	Statute Reference: Sec. 04.11.100
Local Governing Body: Homer Kenai Peninsula Borough		Community Council (if applicable):
Name of Licensee: Finn's, LLC		Doing Business As (DBA): Finn's
Mailing Address: PO Box 1435 Homer, AK 99603		Street Address or Location of Premises: 4287 Homer Spit Road, Unit #8 Homer AK 99603
Phone: 503 347 2950 503 347 6218	Fax:	Email: larsonbjorn@yahoo.com sasharampp@yahoo.com

SECTION B - OWNERSHIP INFORMATION - CORPORATION (if owner is a sole proprietor, skip to SECTION C)

Corporations, LLCs, LLPs and LPs must be registered with the Alaska Division of Corporations.

Name of Entity (Corporation/LLC/LLP/LP):

Finn's, LLC

Is the Entity in "Good Standing" with the Alaska Division of Corporations? Yes No

If no, attach written explanation. Your entity **must** be in compliance with Title 10 of the Alaska Statutes to be a valid liquor licensee.

Entity Members (Must include President, Secretary, Treasurer, Vice-President, Manager and Shareholder/Member with 10% or more of stock)

Name	Title	%	Mailing Address	Telephone Number
Sasha H Raupp	Co-President	50	PO Box 1435 Homer AK 99603	503 347 2950
Bjorn L Larson	Co-President	50	PO Box 1435 Homer AK 99603	503 347 6218

NOTE: If you need additional space, please attach a separate sheet.

SECTION C – OWNERSHIP INFORMATION – SOLE PROPRIETORSHIP (INDIVIDUAL OWNER & SPOUSE)

Individual Licensees/Affiliates (The ABC Board defines an "affiliate" as the spouse or significant other of a licensee. Each affiliate must be listed.)

Name:	Applicant <input type="checkbox"/>	Name:	Applicant <input type="checkbox"/>
Address:	Affiliate <input type="checkbox"/>	Address:	Affiliate <input type="checkbox"/>
Phone:	Date of Birth:	Phone:	Date of Birth:
Name:	Applicant <input type="checkbox"/>	Name:	Applicant <input type="checkbox"/>
Address:	Affiliate <input type="checkbox"/>	Address:	Affiliate <input type="checkbox"/>
Phone:	Date of Birth:	Phone:	Date of Birth:

SECTION D – SUPPLEMENTAL QUESTIONS

Was your business open at least 30 days for 8 hours each day in 2014? Yes No

Was your business open at least 30 days for 8 hours each day in 2015? Yes No

Has any person named in this application been convicted of a felony or Title 4 violation?
If yes, attach a written explanation. Yes No

Has the licensed premises changed from the last diagram submitted?
If yes, attach a new diagram with designated premises areas outlined in red. Yes No

Were your gross receipts from the sale of food at least 50% of your total gross receipts for 2014 and 2015? Yes No

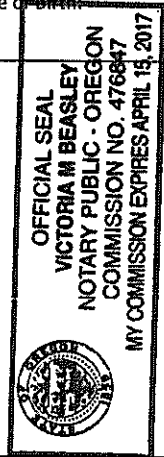

DECLARATION

- I declare under penalty of perjury that I have examined this application, including the accompanying schedules and statements, and to the best of my knowledge and belief it is true, correct, and complete.
- I hereby certify that there have been no changes in officers or stockholders that have not been reported to the Alcoholic Beverage Control Board. The undersigned certifies on behalf of the organized entity, it is understood that a misrepresentation of fact is cause for rejection of this application or revocation of any license issued.
- I further certify that I have read and am familiar with Title 4 of the Alaska statutes and its regulations, and that in accordance with AS 04.11.450, no person other than the licensee(s) has any direct or indirect financial interest in the licensed business.
- I agree to provide all information required by the Alcoholic Beverage Control Board in support of this application.
- As a licensee (sole proprietor or partner), I certify that I have received Alaska alcohol server training and my certification is currently valid.
- As a corporate/LLC licensee, I certify that all agents and employees who serve, sell, or are otherwise responsible for the service, sale, or storage of alcoholic beverages have received Alaska alcohol server training and their certification is currently valid. I further certify that certain shareholders, officers, directors, or members of the entity who are not directly or indirectly responsible for the service, sale, or storage of alcoholic beverages are not Alaska alcohol server training certified and will not be required to be certified.
- As a licensee, I certify that all of my agents and employees tasked with patron identification verification have received alcohol server training and their certification is currently valid.

License Fee	\$ 300.00
Filing Fee	\$ 200.00
TOTAL	\$ 500.00
Late Fee of \$500.00 – if received or postmarked after 12/31/2015	\$
Fingerprint Fee – \$49.75 per person (only for new owners/members)	\$
GRAND TOTAL	\$ 500.00

Licensee Signature <i>Sasha H. Raupp</i>	Printed Name & Title: Sasha H. Raupp Owner/president
Notary Signature <i>Victoria M. Beasley</i>	Subscribed and sworn to before me this 21st day of November, 2015.
Notary Public in and for the State of: Oregon	My commission expires: April 15, 2017

Notary Stamp ↑

Alcoholic Beverage Control Board
550 W 7th Avenue, Suite 1600
Anchorage, AK 99501

Renewal Liquor License 2016/2017

Phone: (907) 269-0350
Email: alcohol.licensing@alaska.gov
<http://commerce.alaska.gov/web/abc/Home.aspx>

License is: Full Year OR Seasonal If seasonal, list dates of operation: May-Sept

SECTION A - LICENSE INFORMATION		
License Number: 5256	License Type: Restaurant/Eating Place-Public Convenience Seasonal	Statute Reference: Sec. 04.11.400(g)
Local Governing Body: Homer Kenai Peninsula Borough		Community Council (if applicable):
Name of Licensee: Mary K. and Evan J. Vogl		Doing Business As (DBA): Little Mermaid
Mailing Address: P.O. Box 3350 Homer, AK 99603		Street Address or Location of Premises: 4246 Homer Spit Road #4 & 6
Phone: 907-435-7142	Fax:	Email: Kathy.vogl@yahoo.com

SECTION B - OWNERSHIP INFORMATION - CORPORATION (if owner is a sole proprietor, skip to SECTION C)

Corporations, LLCs, LLPs and LPs must be registered with the Alaska Division of Corporations.

Name of Entity (Corporation/LLC/LLP/LP):
Mary K. and Evan J. Vogl

Is the Entity in "Good Standing" with the Alaska Division of Corporations? Yes No
If no, attach written explanation. Your entity *must* be in compliance with Title 10 of the Alaska Statutes to be a valid liquor licensee.

Entity Members (Must include President, Secretary, Treasurer, Vice-President, Manager and Shareholder/Member with 10% or more of stock)

Name	Title	%	Mailing Address	Telephone Number

NOTE: If you need additional space, please attach a separate sheet.

SECTION C – OWNERSHIP INFORMATION – SOLE PROPRIETORSHIP (INDIVIDUAL OWNER & SPOUSE)

Individual Licensees/Affiliates (The ABC Board defines an "affiliate" as the spouse or significant other of a licensee. Each affiliate must be listed.)

Name: <u>Mary K. Vogl</u> Address: <u>P O Box 3350</u> <u>Homer, AK 99603</u> Phone: <u>907 435-7142</u>	Applicant <input checked="" type="checkbox"/> Affiliate <input type="checkbox"/> Date of Birth: <u>7-12-74</u>	Name: Address: Phone:	Applicant <input type="checkbox"/> Affiliate <input type="checkbox"/> Date of Birth:
Name: <u>Evan J. Vogl</u> Address: <u>P O Box 3350</u> <u>Homer, AK 99603</u> Phone: <u>907-435-7142</u>	Applicant <input type="checkbox"/> Affiliate <input checked="" type="checkbox"/> Date of Birth: <u>2-19-70</u>	Name: Address: Phone:	Applicant <input type="checkbox"/> Affiliate <input type="checkbox"/> Date of Birth:

SECTION D – SUPPLEMENTAL QUESTIONS

Was your business open at least 30 days for 8 hours each day in 2014?	<input checked="" type="checkbox"/> Yes <input type="checkbox"/> No
Was your business open at least 30 days for 8 hours each day in 2015?	<input checked="" type="checkbox"/> Yes <input type="checkbox"/> No
Has any person named in this application been convicted of a felony or Title 4 violation? If yes, attach a written explanation.	<input type="checkbox"/> Yes <input checked="" type="checkbox"/> No
Has the licensed premises changed from the last diagram submitted? If yes, attach a new diagram with designated premises areas outlined in red.	<input type="checkbox"/> Yes <input checked="" type="checkbox"/> No
Were your gross receipts from the sale of food at least 50% of your total gross receipts for 2014 and 2015?	<input checked="" type="checkbox"/> Yes <input type="checkbox"/> No

DECLARATION

- I declare under penalty of perjury that I have examined this application, including the accompanying schedules and statements, and to the best of my knowledge and belief it is true, correct, and complete.
- I hereby certify that there have been no changes in officers or stockholders that have not been reported to the Alcoholic Beverage Control Board. The undersigned certifies on behalf of the organized entity, it is understood that a misrepresentation of fact is cause for rejection of this application or revocation of any license issued.
- I further certify that I have read and am familiar with Title 4 of the Alaska statutes and its regulations, and that in accordance with AS 04.11.450, no person other than the licensee(s) has any direct or indirect financial interest in the licensed business.
- I agree to provide all information required by the Alcoholic Beverage Control Board in support of this application.
- As a licensee (sole proprietor or partner), I certify that I have received Alaska alcohol server training and my certification is currently valid.
- As a corporate/LLC licensee, I certify that all agents and employees who serve, sell, or are otherwise responsible for the service, sale, or storage of alcoholic beverages have received Alaska alcohol server training and their certification is currently valid. I further certify that certain shareholders, officers, directors, or members of the entity who are not directly or indirectly responsible for the service, sale, or storage of alcoholic beverages are not Alaska alcohol server training certified and will not be required to be certified.
- As a licensee, I certify that all of my agents and employees tasked with patron identification verification have received alcohol server training and their certification is currently valid.

License Fee	\$ 300.00
Filing Fee	\$ 200.00
TOTAL	\$ 500.00
Late Fee of \$500.00 – if received or postmarked after 12/31/2015	\$
Fingerprint Fee – \$49.75 per person (only for new owners/members)	\$
GRAND TOTAL	\$ 500-

Licensee Signature <u>Mary K. Vogl</u>	Printed Name & Title: <u>Mary K. Vogl</u>
Notary Signature <u>Stephanie Green</u>	Subscribed and sworn to before me this <u>16th</u> day of <u>November</u> , <u>2015</u> .
Notary Public in and for the State of <u>Alaska</u>	My commission expires: <u>June 16, 2019</u>

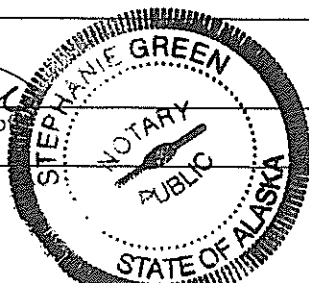



THE STATE
of **ALASKA**

GOVERNOR BILL WALKER

Department of Commerce, Community,
and Economic Development

ALCOHOLIC BEVERAGE CONTROL BOARD

Sarah Daulton Oates
550 W 7th Avenue, Suite 1600
Anchorage, AK 99501
Phone: 907.269.0350
alcohol.licensing@alaska.gov

DEC 11 2015
[Signature]

December 8, 2015

City of Homer
Attn: City Clerk

VIA Email: clerk@cityofhomer-ak.gov

Cc: joanne@borough.kenai.ak.us
jblankenship@borough.kenai.ak.us
kring@borough.kenai.ak.us

Re: Notice of 2016/2017 Liquor License Renewal Applications

Dear Clerk,

We have received a renewal application for each of the following licenses within your jurisdiction:

Lic. #	Doing Business As	License Type	Licensee	Premises Address
98	The Alibi	Beverage Dispensary	Mix Rocks, LLC	453 E Pioneer Avenue
1002	Salty Dawg Saloon	Beverage Dispensary	Sdawg, Inc.	4380 Homer Spit Road
2300	Down East Saloon	Beverage Dispensary	Down East, Inc.	3125 E End Road
5173	Pho & Thai Restaurant	Restaurant/Eating Place-Public Convenience	Bunloeun Chin	345 Sterling Hwy. Ste. 101

A local governing body as defined under AS 04.21.080(b)(18) may protest the approval of an application(s) pursuant to AS 04.11.480 by providing the board **and** the applicant with a clear and concise written statement of reasons in support of a protest within 60 days of receipt of this notice. If a protest is filed, the board will not approve the application unless it finds that the protest is arbitrary, capricious, and unreasonable. Instead, in accordance with AS 04.11.510(b), the board will notify the applicant that the application is denied for reasons stated in the protest. The applicant is entitled to an informal conference with either the director or the board and, if not satisfied by the informal conference, is entitled to a formal hearing in accordance with AS 44.62.330-44.62-630. **IF THE APPLICANT REQUESTS A HEARING, THE LOCAL GOVERNING BODY MUST ASSIST IN OR UNDERTAKE THE DEFENSE OF ITS PROTEST.**

Under AS 04.11.420(a), the board may not issue a license or permit for premises in a municipality where a zoning regulation or ordinance prohibits the sale or consumption of alcoholic beverages, unless a variance of the regulation or ordinance has been approved. Under AS 04.11.420(b) municipalities must inform the board of zoning regulations or ordinances which prohibit the sale or consumption of alcoholic beverages. If a municipal zoning regulation or ordinance prohibits the sale or consumption of alcoholic beverages at the proposed premises and no variance of the regulation or ordinance has been approved, please notify our office and provide a certified copy of the regulation or ordinance if you have not previously done so.

Protest under AS 04.11.480 and the prohibition of sale or consumption of alcoholic beverages as required by zoning regulation or ordinance under AS 04.11.420(a) are two separate and distinct subjects. Please bear that in mind when responding to this notice.

AS 04.21.010(d), if applicable, requires the municipality to provide written notice to the appropriate community council(s).

If you wish to protest the application(s) referenced above, please do so in the prescribed manner and within the prescribed time. Please show proof of service upon the applicant. For additional information regarding local governing body protests, please refer to 3 AAC 304.145.

If you have any questions or concerns or require additional information, please feel free to contact our licensing unit at alcohol.licensing@alaska.gov.

Sincerely,



Sarah Daulton Oates

Records & Licensing Supervisor
sarah.oates@alaska.gov

#12794

Alcoholic Beverage Control Board 550 W 7 th Avenue, Suite 1600 Anchorage, AK 99501	Renewal Liquor License 2016/2017	Phone: (907) 269-0350 Email: alcohol.licensing@alaska.gov http://commerce.alaska.gov/web/abc/Home.aspx
---	---	---

License is: Full Year OR Seasonal If seasonal, list dates of operation: _____

SECTION A - LICENSE INFORMATION		
License Number: 98	License Type: Beverage Dispensary	Statute Reference: Sec. 04.11.090
Local Governing Body: Homer Kenai Peninsula Borough	Community Council (if applicable):	
Name of Licensee: Mix Rocks, LLC	Doing Business As (DBA): The Alibi	
Mailing Address: 453 E Pioneer	Street Address or Location of Premises: 453 E Pioneer Ave	
Phone: 907-235-9199	Fax: 907-226-2436	Email: megan.palma74@gmail.com

SECTION B - OWNERSHIP INFORMATION - CORPORATION (if owner is a sole proprietor, skip to SECTION C)				
<i>Corporations, LLCs, LLPs and LPs must be registered with the Alaska Division of Corporations.</i>				
Name of Entity (Corporation/LLC/LLP/LP): Mix Rocks, LLC				
Is the Entity in "Good Standing" with the Alaska Division of Corporations? <input checked="" type="checkbox"/> Yes <input type="checkbox"/> No If no, attach written explanation. Your entity <i>must</i> be in compliance with Title 10 of the Alaska Statutes to be a valid liquor licensee.				
Entity Members (Must include President, Secretary, Treasurer, Vice-President, Manager and Shareholder/Member with 10% or more of stock)				
Name	Title	%	Mailing Address	Telephone Number
Megan Palma	Man. Member	50	453 E Pioneer	907-362-1076
Nelton Palmas	MAN. MEMBER	50	453 E Pioneer	760-709-1009
NOTE: If you need additional space, please attach a separate sheet.				

OCT 27 '15 AM 11:57

SECTION C – OWNERSHIP INFORMATION – SOLE PROPRIETORSHIP (INDIVIDUAL OWNER & SPOUSE)

Individual Licensees/Affiliates (The ABC Board defines an "affiliate" as the spouse or significant other of a licensee. Each affiliate must be listed.)

Name:	Applicant <input type="checkbox"/>	Name:	Applicant <input type="checkbox"/>
Address:	Affiliate <input type="checkbox"/>	Address:	Affiliate <input type="checkbox"/>
Phone:	Date of Birth:	Phone:	Date of Birth:
Name:	Applicant <input type="checkbox"/>	Name:	Applicant <input type="checkbox"/>
Address:	Affiliate <input type="checkbox"/>	Address:	Affiliate <input type="checkbox"/>
Phone:	Date of Birth:	Phone:	Date of Birth:

SECTION D – SUPPLEMENTAL QUESTIONS

Was your business open at least 30 days for 8 hours each day in 2014? Yes No

Was your business open at least 30 days for 8 hours each day in 2015? Yes No

Has any person named in this application been convicted of a felony or Title 4 violation? Yes No
If yes, attach a written explanation.

Has the licensed premises changed from the last diagram submitted? Yes No
If yes, attach a new diagram with designated premises areas outlined in red.

DECLARATION

- I declare under penalty of perjury that I have examined this application, including the accompanying schedules and statements, and to the best of my knowledge and belief it is true, correct, and complete.
- I hereby certify that there have been no changes in officers or stockholders that have not been reported to the Alcoholic Beverage Control Board. The undersigned certifies on behalf of the organized entity, it is understood that a misrepresentation of fact is cause for rejection of this application or revocation of any license issued.
- I further certify that I have read and am familiar with Title 4 of the Alaska statutes and its regulations, and that in accordance with AS 04.11.450, no person other than the licensee(s) has any direct or indirect financial interest in the licensed business.
- I agree to provide all information required by the Alcoholic Beverage Control Board in support of this application.
- As a licensee (sole proprietor or partner), I certify that I have received Alaska alcohol server training and my certification is currently valid.
- As a corporate/LLC licensee, I certify that all agents and employees who serve, sell, or are otherwise responsible for the service, sale, or storage of alcoholic beverages have received Alaska alcohol server training and their certification is currently valid. I further certify that certain shareholders, officers, directors, or members of the entity who are not directly or indirectly responsible for the service, sale, or storage of alcoholic beverages are not Alaska alcohol server training certified and will not be required to be certified.
- As a licensee, I certify that all of my agents and employees tasked with patron identification verification have received alcohol server training and their certification is currently valid.

License Fee	\$ 2500.00
Filing Fee	\$ 200.00
TOTAL	\$ 2700.00
Late Fee of \$500.00 – if received or postmarked after 12/31/2015	\$
Fingerprint Fee – \$49.75 per person (only for new owners/members)	\$
GRAND TOTAL	\$ 2700

Licensee Signature <i>Megan Palma</i>	Printed Name & Title: Megan Palma, Managing Member (owner)
Notary Signature <i>Virginia D. Wise</i>	scribed and sworn to before me this day of <u>October</u> , 2015.
Notary Public in and for the State of: Alaska	My commission expires: <u>06-01-2017</u>

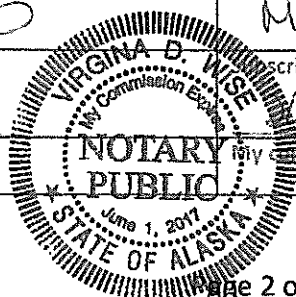

12753

Alcoholic Beverage Control Board
550 W 7th Avenue, Suite 1600
Anchorage, AK 99501

Renewal Liquor License 2016/2017

Phone: (907) 269-0350
Email: alcohol.licensing@alaska.gov
<http://commerce.alaska.gov/web/abc/Home.aspx>

License is: Full Year OR Seasonal If seasonal, list dates of operation: _____

SECTION A - LICENSE INFORMATION		
License Number: 1002	License Type: Beverage Dispensary	Statute Reference: Sec. 04.11.090
Local Governing Body: Homer Kenai Peninsula Borough	Community Council (if applicable): Homer City Council 491. E. PIONEER AVE HOMER AK 99603	
Name of Licensee: Sdawg Inc.	Doing Business As (DBA): Salty Dawg Saloon	
Mailing Address: P.O. Box 2581 HOMER, AK 99603	Street Address or Location of Premises: 4380 Homer Spit Road	
Phone: 907-235-6718	Fax:	Email: john@saltydawgsaloon.com

SECTION B - OWNERSHIP INFORMATION - CORPORATION (if owner is a sole proprietor, skip to SECTION C)				
Corporations, LLCs, LLPs and LPs must be registered with the Alaska Division of Corporations.				
Name of Entity (Corporation/LLC/LLP/LP): Sdawg Inc.				
Is the Entity in "Good Standing" with the Alaska Division of Corporations? <input checked="" type="checkbox"/> Yes <input type="checkbox"/> No If no, attach written explanation. Your entity must be in compliance with Title 10 of the Alaska Statutes to be a valid liquor licensee.				
Entity Members (Must include President, Secretary, Treasurer, Vice-President, Manager and Shareholder/Member with 10% or more of stock)				
Name	Title	%	Mailing Address	Telephone Number
JOHN WARREN	President	100	PO BOX 2581 HOMER, AK 99603	907-399-5564
NOTE: If you need additional space, please attach a separate sheet.				

SECTION C – OWNERSHIP INFORMATION – SOLE PROPRIETORSHIP (INDIVIDUAL OWNER & SPOUSE)

Individual Licensees/Affiliates (The ABC Board defines an "affiliate" as the spouse or significant other of a licensee. Each affiliate must be listed.)

Name:	Applicant <input checked="" type="checkbox"/> Affiliate <input type="checkbox"/>	Name:	Applicant <input type="checkbox"/> Affiliate <input type="checkbox"/>
Address:	Date of Birth:	Address:	Date of Birth:
Phone:		Phone:	
Name:	Applicant <input type="checkbox"/> Affiliate <input type="checkbox"/>	Name:	Applicant <input type="checkbox"/> Affiliate <input type="checkbox"/>
Address:	Date of Birth:	Address:	Date of Birth:
Phone:		Phone:	

SECTION D – SUPPLEMENTAL QUESTIONS

Was your business open at least 30 days for 8 hours each day in 2014? Yes No

Was your business open at least 30 days for 8 hours each day in 2015? Yes No

Has any person named in this application been convicted of a felony or Title 4 violation? Yes No
If yes, attach a written explanation.

Has the licensed premises changed from the last diagram submitted? Yes No
If yes, attach a new diagram with designated premises areas outlined in red.

DECLARATION

- I declare under penalty of perjury that I have examined this application, including the accompanying schedules and statements, and to the best of my knowledge and belief it is true, correct, and complete.
- I hereby certify that there have been no changes in officers or stockholders that have not been reported to the Alcoholic Beverage Control Board. The undersigned certifies on behalf of the organized entity, it is understood that a misrepresentation of fact is cause for rejection of this application or revocation of any license issued.
- I further certify that I have read and am familiar with Title 4 of the Alaska statutes and its regulations, and that in accordance with AS 04.11.450, no person other than the licensee(s) has any direct or indirect financial interest in the licensed business.
- I agree to provide all information required by the Alcoholic Beverage Control Board in support of this application.
- As a licensee (sole proprietor or partner), I certify that I have received Alaska alcohol server training and my certification is currently valid.
- As a corporate/LLC licensee, I certify that all agents and employees who serve, sell, or are otherwise responsible for the service, sale, or storage of alcoholic beverages have received Alaska alcohol server training and their certification is currently valid. I further certify that certain shareholders, officers, directors, or members of the entity who are not directly or indirectly responsible for the service, sale, or storage of alcoholic beverages are not Alaska alcohol server training certified and will not be required to be certified.
- As a licensee, I certify that all of my agents and employees tasked with patron identification verification have received alcohol server training and their certification is currently valid.

License Fee	\$ 2500.00
Filing Fee	\$ 200.00
TOTAL	\$ 2700.00
Late Fee of \$500.00 – if received or postmarked after 12/31/2015	\$
Fingerprint Fee – \$49.75 per person (only for new owners/members)	\$
GRAND TOTAL	\$

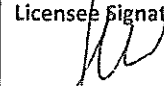
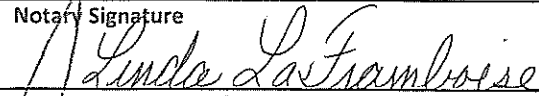
Licensee Signature 	Printed Name & Title: JOHN L. WARREN OWNER
Notary Signature 	Subscribed and sworn to before me this 20th day of October
Notary Public in and for the State of: Alaska	My commission expires: 5/2/19

13065

Alcoholic Beverage Control Board
 550 W 7th Avenue, Suite 1600
 Anchorage, AK 99501

**Renewal Liquor License
 2016/2017**

Phone: (907) 269-0350
 Email: alcohol.licensing@alaska.gov
<http://commerce.alaska.gov/web/abc/Home.aspx>

License is: Full Year OR Seasonal If seasonal, list dates of operation: _____

SECTION A - LICENSE INFORMATION		
License Number: 2300	License Type: Beverage Dispensary	Statute Reference: Sec. 04.11.090
Local Governing Body: Homer Kenai Peninsula Borough		Community Council (if applicable):
Name of Licensee: Down East, Inc.		Doing Business As (DBA): Down East Saloon
Mailing Address: Homer, AK 3125 EAST END RD 99603		Street Address or Location of Premises: 3125 E End Road Homer AK 99603
Phone:	Fax:	Email:

SECTION B – OWNERSHIP INFORMATION – CORPORATION (if owner is a sole proprietor, skip to SECTION C)				
<i>Corporations, LLCs, LLPs and LPs must be registered with the Alaska Division of Corporations.</i>				
Name of Entity (Corporation/LLC/LLP/LP): Down East, Inc.				
Is the Entity in "Good Standing" with the Alaska Division of Corporations? <input checked="" type="checkbox"/> Yes <input type="checkbox"/> No If no, attach written explanation. Your entity must be in compliance with Title 10 of the Alaska Statutes to be a valid liquor licensee.				
Entity Members (Must include President, Secretary, Treasurer, Vice-President, Manager and Shareholder/Member with 10% or more of stock)				
Name	Title	%	Mailing Address	Telephone Number
Kathleen McDonough	Pres	100	PO Box 2484 Homer AK	299-0124

NOTE: If you need additional space, please attach a separate sheet.

SECTION C – OWNERSHIP INFORMATION – SOLE PROPRIETORSHIP (INDIVIDUAL OWNER & SPOUSE)

Individual Licensees/Affiliates (The ABC Board defines an "affiliate" as the spouse or significant other of a licensee. Each affiliate must be listed.)

Name: Address: Phone:	Applicant <input type="checkbox"/> Affiliate <input type="checkbox"/> Date of Birth:	Name: Address: Phone:	Applicant <input type="checkbox"/> Affiliate <input type="checkbox"/> Date of Birth:
Name: Address: Phone:	Applicant <input type="checkbox"/> Affiliate <input type="checkbox"/> Date of Birth:	Name: Address: Phone:	Applicant <input type="checkbox"/> Affiliate <input type="checkbox"/> Date of Birth:

SECTION D – SUPPLEMENTAL QUESTIONS

Was your business open at least 30 days for 8 hours each day in 2014? Yes No

Was your business open at least 30 days for 8 hours each day in 2015? Yes No

Has any person named in this application been convicted of a felony or Title 4 violation?
If yes, attach a written explanation. Yes No

Has the licensed premises changed from the last diagram submitted?
If yes, attach a new diagram with designated premises areas outlined in red. Yes No

DECLARATION

- I declare under penalty of perjury that I have examined this application, including the accompanying schedules and statements, and to the best of my knowledge and belief it is true, correct, and complete.
- I hereby certify that there have been no changes in officers or stockholders that have not been reported to the Alcoholic Beverage Control Board. The undersigned certifies on behalf of the organized entity, it is understood that a misrepresentation of fact is cause for rejection of this application or revocation of any license issued.
- I further certify that I have read and am familiar with Title 4 of the Alaska statutes and its regulations, and that in accordance with AS 04.11.450, no person other than the licensee(s) has any direct or indirect financial interest in the licensed business.
- I agree to provide all information required by the Alcoholic Beverage Control Board in support of this application.
- As a licensee (sole proprietor or partner), I certify that I have received Alaska alcohol server training and my certification is currently valid.
- As a corporate/LLC licensee, I certify that all agents and employees who serve, sell, or are otherwise responsible for the service, sale, or storage of alcoholic beverages have received Alaska alcohol server training and their certification is currently valid. I further certify that certain shareholders, officers, directors, or members of the entity who are not directly or indirectly responsible for the service, sale, or storage of alcoholic beverages are not Alaska alcohol server training certified and will not be required to be certified.
- As a licensee, I certify that all of my agents and employees tasked with patron identification verification have received alcohol server training and their certification is currently valid.

License Fee	\$ 2500.00
Filing Fee	\$ 200.00
TOTAL	\$ 2700.00
Late Fee of \$500.00 – if received or postmarked after 12/31/2015	\$
Fingerprint Fee – \$49.75 per person (only for new owners/members)	\$
GRAND TOTAL	\$2700.00

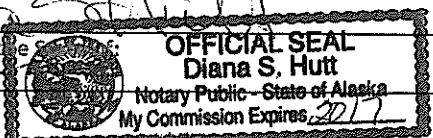
Licensee Signature <i>Kathleen E. McDonough</i>	Printed Name & Title: KATHLEEN E. McDONOUGH
Notary Signature <i>Diana S. Hutt</i>	Subscribed and sworn to before me this <u>19</u> day of <u>November</u> , 20 <u>15</u> .
Notary Public in and for the State of <u>Alaska</u> 	My commission expires: <u>5/2017</u>

#12850

Alcoholic Beverage Control Board 550 W 7 th Avenue, Suite 1600 Anchorage, AK 99501	Renewal Liquor License 2016/2017	Phone: (907) 269-0950 Email: alcohol.licensing@alaska.gov http://commerce.alaska.gov/web/abc/Home.aspx
---	---	---

License is: Full Year OR Seasonal If seasonal, list dates of operation: _____

SECTION A - LICENSE INFORMATION		
License Number: 5179	License Type: Restaurant/Eating Place-Public Convenience	Statute Reference: Sec. 04.13.400(g)
Local Governing Body: Homer Kenai Peninsula Borough		Community Council (if applicable):
Name of Licensee: Bunleoun Chin		Doing Business As (DBA): Pho & Thai Restaurant
Mailing Address: Same 345 Sterling Highway, Ste 101		Street Address or Location of Premises:
Phone: 907-435-3991	Fax:	Email: Bun-564@hotmail.com

SECTION B - OWNERSHIP INFORMATION - CORPORATION (If owner is a sole proprietor, skip to SECTION C)				
<i>Corporations, LLCs, LLPs and LPs must be registered with the Alaska Division of Corporations.</i>				
Name of Entity (Corporation/LLC/LLP/LP): Bunleoun Chin				
Is the Entity in "Good Standing" with the Alaska Division of Corporations? <input checked="" type="checkbox"/> Yes <input type="checkbox"/> No If no, attach written explanation. Your entity must be in compliance with Title 10 of the Alaska Statutes to be a valid liquor licensee.				
Entity Members (Must include President, Secretary, Treasurer, Vice-President, Manager and Shareholder/Member with 10% or more of stock)				
Name	Title	%	Mailing Address	Telephone Number
NOTE: If you need additional space, please attach a separate sheet.				

OCT 27 '15 AM 11:57

SECTION C - OWNERSHIP INFORMATION - SOLE PROPRIETORSHIP (INDIVIDUAL OWNER & SPOUSE)			
Individual Licensees/Affiliates (The ABC Board defines an "affiliate" as the spouse or significant other of a licensee. Each affiliate must be listed.)			
Name: <u>Bun Odeon Clin</u>	Applicant <input checked="" type="checkbox"/> Affiliate <input checked="" type="checkbox"/>	Name:	Applicant <input type="checkbox"/> Affiliate <input type="checkbox"/>
Address: <u>345 Sterling Hwy 101</u>	Date of Birth: <u>12-03-1965</u>	Address:	Date of Birth:
Phone: <u>907-435-3991</u>		Phone:	
Name: <u>Uralwan Promison</u>	Applicant <input type="checkbox"/> Affiliate <input checked="" type="checkbox"/>	Name:	Applicant <input type="checkbox"/> Affiliate <input type="checkbox"/>
Address: <u>345 Sterling Hwy 101</u>	Date of Birth: <u>01-12-1970</u>	Address:	Date of Birth:
Phone: <u>907-435-3991</u>		Phone:	

SECTION D - SUPPLEMENTAL QUESTIONS	
Was your business open at least 90 days for 8 hours each day in 2014?	<input checked="" type="checkbox"/> Yes <input type="checkbox"/> No
Was your business open at least 90 days for 8 hours each day in 2015?	<input checked="" type="checkbox"/> Yes <input type="checkbox"/> No
Has any person named in this application been convicted of a felony or Title 4 violation? If yes, attach a written explanation.	<input type="checkbox"/> Yes <input checked="" type="checkbox"/> No
Has the licensed premises changed from the last diagram submitted? If yes, attach a new diagram with designated premises areas outlined in red.	<input type="checkbox"/> Yes <input checked="" type="checkbox"/> No
Were your gross receipts from the sale of food at least 50% of your total gross receipts for 2014 and 2015?	<input checked="" type="checkbox"/> Yes <input type="checkbox"/> No

DECLARATION	
<ul style="list-style-type: none"> I declare under penalty of perjury that I have examined this application, including the accompanying schedules and statements, and to the best of my knowledge and belief it is true, correct, and complete. I hereby certify that there have been no changes in officers or stockholders that have not been reported to the Alcoholic Beverage Control Board. The undersigned certifies on behalf of the organized entity, it is understood that a misrepresentation of fact is cause for rejection of this application or revocation of any license issued. I further certify that I have read and am familiar with Title 4 of the Alaska statutes and its regulations, and that in accordance with AS 04.13.450, no person other than the licensee(s) has any direct or indirect financial interest in the licensed business. I agree to provide all information required by the Alcoholic Beverage Control Board in support of this application. As a licensee (sole proprietor or partner), I certify that I have received Alaska alcohol server training and my certification is currently valid. As a corporate/LLC licensee, I certify that all agents and employees who serve, sell, or are otherwise responsible for the service, sale, or storage of alcoholic beverages have received Alaska alcohol server training and their certification is currently valid. I further certify that certain shareholders, officers, directors, or members of the entity who are not directly or indirectly responsible for the service, sale, or storage of alcoholic beverages are not Alaska alcohol server training certified and will not be required to be certified. As a licensee, I certify that all of my agents and employees tasked with patron identification verification have received alcohol server training and their certification is currently valid. 	

License Fee	\$ 600.00
Filing Fee	\$ 200.00
TOTAL	\$ 800.00
Late Fee of \$500.00 - If received or postmarked after 12/31/2015	\$
Fingerprint Fee - \$49.75 per person (only for new owners/members)	\$
GRAND TOTAL	\$

Licensee Signature <i>[Signature]</i>	Notary Public HELEN PHIPPS State of Alaska My Commission Expires Feb. 8, 2018	Printed Name & Title: <u>Helen Phipps FSR</u>
Notary Signature <i>[Signature]</i>		Subscribed and sworn to before me this <u>02</u> day of <u>NOV</u> , <u>2015</u> .
Notary Public in and for the State of: <u>Alaska KPB-Homer</u>		My commission expires: <u>Feb 8, 2018</u>

Renewal Application

Page 2 of 2

OCT 27 '15 04:13:57

Nov. 02/12/2015



THE STATE
of **ALASKA**
GOVERNOR BILL WALKER

Department of Commerce, Community,
and Economic Development

ALCOHOLIC BEVERAGE CONTROL BOARD

Sarah Daulton Oates
550 W 7th Avenue, Suite 1600
Anchorage, AK 99501
Phone: 907.269.0350
alcohol.licensing@alaska.gov

December 11, 2015

City of Homer
Attn: City Clerk
VIA Email: clerk@cityofhomer-ak.gov
Cc: joanne@borough.kenai.ak.us
jblankenship@borough.kenai.ak.us
kring@borough.kenai.ak.us

Re: Notice of 2016/2017 Liquor License Renewal Applications

Dear Clerk,

We have received a renewal application for each of the following licenses within your jurisdiction:

Lic. #	Doing Business As	License Type	Licensee	Premises Address
367	BPO Elks Lodge #2127	Club	BPO Elks Lodge #2127	215 W Jenny Way
1085	Kharacters	Beverage Dispensary	Wonderful, LLC	3851 Shelford
1252	AJ's Oldtown Steakhouse & Tavern	Beverage Dispensary	APS Investments, LLC	120 W Bunnel Avenue
2673	Captain Patties Fish House	Restaurant/Eating Place-Seasonal	Captain Ptties Fish House, Inc.	4241 Homer Spit Road #1
3210	Café Cups	Restaurant/Eating Place	Bivalves, Inc.	162 W Pioneer Avenue
4164	Finn's	Restaurant/Eating Place-Seasonal	Finn's, LLC	4287 Homer Spit Road, Unit #4
5256	Little Mermaid	Restaurant/Eating Place-Public Convenience Seasonal	Mary K and Evan J Vogl	4246 Homer Spit Road #4 & 6

A local governing body as defined under AS 04.21.080(b)(18) may protest the approval of an application(s) pursuant to AS 04.11.480 by providing the board **and** the applicant with a clear and concise written statement of reasons in support of a protest within 60 days of receipt of this notice. If a protest is filed, the board will not approve the application unless it finds that the protest is arbitrary, capricious, and unreasonable. Instead, in accordance with AS 04.11.510(b),



KENAI PENINSULA BOROUGH

144 North Binkley St., Soldotna, Alaska 99669-7520
1-800-478-4441, Ext. 2160 • 907-714-2160 • Fax 907-714-2388
www.kpb.us • assemblyclerk@kpb.us



JOHNI BLANKENSHIP, MMC
BOROUGH CLERK

December 15, 2015

Ms. Sarah Oates
Records & Licensing Supervisor
Alcoholic Beverage Control Board
550 W 7th Ave, Ste. 1600
Anchorage, AK 99501-3567

RE: Non-Objection of License Renewal
Business Name : The Alibi
License Type : Beverage Dispensary
License Location : City of Homer
License No. : 98

Dear Ms. Oates,

This serves to advise that the Finance Department has reviewed the above referenced application and has no objection to the renewal of this license.

Should you have any questions, or need additional information, please do not hesitate to contact our office.

Sincerely,

Johni Blankenship, MMC
Borough Clerk

JB/klr

cc: Applicant
City of Homer
KPB Finance Department
File

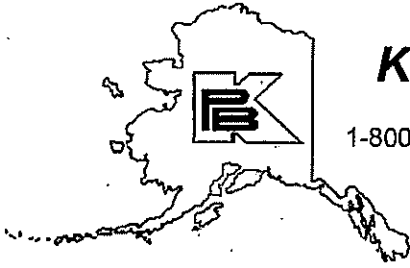

KENAI PENINSULA BOROUGH

144 North Binkley St., Soldotna, Alaska 99669-7520
1-800-478-4441, Ext. 2160 • 907-714-2160 • Fax 907-714-2388
www.kpb.us • assemblyclerk@kpb.us



**JOHNI BLANKENSHIP, MMC
BOROUGH CLERK**

December 16, 2015

Ms. Sarah Oates
Records & Licensing Supervisor
Alcoholic Beverage Control Board
550 W 7th Ave, Ste. 1600
Anchorage, AK 99501-3567

RE: Non-Objection of License Renewal

Business Name	:	Pho & Thai Restaurant
License Type	:	Restaurant Eating Place-Public Convenience
License Location	:	City of Homer
License No.	:	5173

Dear Ms. Oates,

This serves to advise that the Finance Department has reviewed the above referenced application and has no objection to the renewal of this license.

Should you have any questions, or need additional information, please do not hesitate to contact our office.

Sincerely,

John Blankenship, MMC
Borough Clerk

JB/klr

cc: Applicant
City of Homer
KPB Finance Department
File

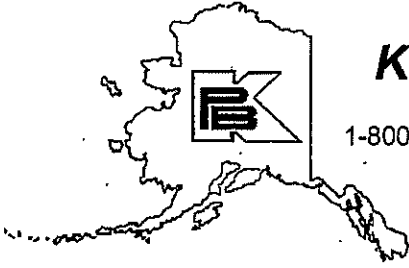

KENAI PENINSULA BOROUGH

144 North Binkley St., Soldotna, Alaska 99669-7520
1-800-478-4441, Ext. 2160 • 907-714-2160 • Fax 907-714-2388
www.kpb.us • assemblyclerk@kpb.us



**JOHNI BLANKENSHIP, MMC
BOROUGH CLERK**

December 16, 2015

Ms. Sarah Oates
Records & Licensing Supervisor
Alcoholic Beverage Control Board
550 W 7th Ave, Ste. 1600
Anchorage, AK 99501-3567

RE: Non-Objection of License Renewal
Business Name : Salty Dawg Saloon
License Type : Beverage Dispensary
License Location : City of Homer
License No. : 1002

Dear Ms. Oates,

This serves to advise that the Finance Department has reviewed the above referenced application and has no objection to the renewal of this license.

Should you have any questions, or need additional information, please do not hesitate to contact our office.

Sincerely,

Johni Blankenship, MMC
Borough Clerk

JB/klr

cc: Applicant
City of Homer
KPB Finance Department
File



KENAI PENINSULA BOROUGH

144 North Binkley St., Soldotna, Alaska 99669-7520
1-800-478-4441, Ext. 2160 • 907-714-2160 • Fax 907-714-2388
www.kpb.us • assemblyclerk@kpb.us



JOHNI BLANKENSHIP, MMC
BOROUGH CLERK

December 16, 2015

Ms. Sarah Oates
Records & Licensing Supervisor
Alcoholic Beverage Control Board
550 W 7th Ave, Ste. 1600
Anchorage, AK 99501-3567

RE: Non-Objection of License Renewal
Business Name : Down East Saloon
License Type : Beverage Dispensary
License Location : City of Homer
License No. : 2300

Dear Ms. Oates,

This serves to advise that the Finance Department has reviewed the above referenced application and has no objection to the renewal of this license.

Should you have any questions, or need additional information, please do not hesitate to contact our office.

Sincerely,

Johni Blankenship, MMC
Borough Clerk

JB/klr

cc: Applicant
City of Homer
KPB Finance Department
File



KENAI PENINSULA BOROUGH

144 North Binkley St., Soldotna, Alaska 99669-7520
1-800-478-4441, Ext. 2160 • 907-714-2160 • Fax 907-714-2388
www.kpb.us • assemblyclerk@kpb.us



**JOHNI BLANKENSHIP, MMC
BOROUGH CLERK**

December 16, 2015

Ms. Sarah Oates
Records & Licensing Supervisor
Alcoholic Beverage Control Board
550 W 7th Ave, Ste. 1600
Anchorage, AK 99501-3567

RE: Non-Objection of License Renewal
Business Name : Salty Dawg Saloon
License Type : Beverage Dispensary
License Location : City of Homer
License No. : 1002

Dear Ms. Oates,

This serves to advise that the Finance Department has reviewed the above referenced application and has no objection to the renewal of this license.

Should you have any questions, or need additional information, please do not hesitate to contact our office.

Sincerely,

Johni Blankenship, MMC
Borough Clerk

JB/klr

cc: Applicant
City of Homer
KPB Finance Department
File

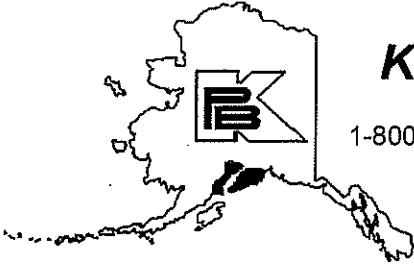

KENAI PENINSULA BOROUGH

144 North Binkley St., Soldotna, Alaska 99669-7520
1-800-478-4441, Ext. 2160 • 907-714-2160 • Fax 907-714-2388
www.kpb.us • assemblyclerk@kpb.us



**JOHNI BLANKENSHIP, MMC
BOROUGH CLERK**

December 16, 2015

Ms. Sarah Oates
Records & Licensing Supervisor
Alcoholic Beverage Control Board
550 W 7th Ave, Ste. 1600
Anchorage, AK 99501-3567

RE: Non-Objection of License Renewal
Business Name : Down East Saloon
License Type : Beverage Dispensary
License Location : City of Homer
License No. : 2300

Dear Ms. Oates,

This serves to advise that the Finance Department has reviewed the above referenced application and has no objection to the renewal of this license.

Should you have any questions, or need additional information, please do not hesitate to contact our office.

Sincerely,

Johni Blankenship, MMC
Borough Clerk

JB/klr

cc: Applicant
City of Homer
KPB Finance Department
File

ORDINANCE REFERENCE SHEET
2016 ORDINANCE
ORDINANCE 16-01

An Ordinance of the City Council of Homer, Alaska, Amending Homer City Code 2.08.030, Composition of Governing Body – Terms of Office, Homer City Code 4.35.010, Review of Election Documents by Canvass Board, and Homer City Code 4.40.010, Runoff Election – Required; and Enacting Homer City Code 4.35.020, Votes Required to be Elected, Homer City Code 4.35.030, Tie Vote, And Homer City Code 4.35.040, Certification of Election; Regarding the Procedure for Electing the Mayor and Council Members.

Sponsor: Mayor

1. Council Regular Meeting January 11, 2016 Introduction
 - a. Memorandum 16-xxx from City Clerk as backup

1 CITY OF HOMER
2 HOMER, ALASKA

3 Mayor

4 ORDINANCE 16-01

5
6 AN ORDINANCE OF THE CITY COUNCIL OF HOMER, ALASKA,
7 AMENDING HOMER CITY CODE 2.08.030, COMPOSITION OF
8 GOVERNING BODY – TERMS OF OFFICE, HOMER CITY CODE
9 4.35.010, REVIEW OF ELECTION DOCUMENTS BY CANVASS
10 BOARD, AND HOMER CITY CODE 4.40.010, RUNOFF ELECTION –
11 REQUIRED; AND ENACTING HOMER CITY CODE 4.35.020, VOTES
12 REQUIRED TO BE ELECTED, HOMER CITY CODE 4.35.030, TIE
13 VOTE, AND HOMER CITY CODE 4.35.040, CERTIFICATION OF
14 ELECTION; REGARDING THE PROCEDURE FOR ELECTING THE
15 MAYOR AND COUNCIL MEMBERS.

16
17 NOW, THEREFORE, THE CITY OF HOMER ORDAINS:

18
19 Section 1. Homer City Code 2.08.030, Composition of governing body – Terms of
20 office, is amended to read as follows:

21
22 2.08.030 Composition of governing body – Terms of office.

23 a. The governing body of the City of Homer shall consist of six Council members, two
24 of whom are elected **at large** each year **for three-year terms** and **until a successor qualifies**
25 shall serve for a term of three years.

26 b. The Mayor shall be elected for a two-year term **and until a successor qualifies.**

27 c. ~~A person~~ Persons so elected to office under this chapter shall take office **at the**
28 **regular council meeting at which the person's election is finally certified, immediately**
29 **following that certification** ~~on the first Monday following certification of the election in~~
30 ~~which that person was elected. There will be a special meeting, held at the regular time, for~~
31 ~~the purpose of administering the oath of office to the elected candidates.~~

32
33 Section 2. Homer City Code 4.10.010, Declaration of candidacy, is amended to read as
34 follows:

35
36 4.10.010 Declaration of candidacy.

37 a. Time. **A person declares candidacy for an elective city office by** ~~The period for~~
38 ~~filing a~~ declarations of candidacy **with the City Clerk on or after** shall be August 1st **and not**
39 **later than 4:30 p.m. on** through August 15th; **provided that if** ~~Should August 15th~~ **is** fall on a
40 Saturday or Sunday, **a declaration of candidacy may be filed no later than 4:30 p.m. on**
41 **the following Monday** ~~then candidates shall have until Monday following to file their~~
42 ~~declarations as provided in the rules of counting time (see HCC 4.01.020, Definitions).~~

[Added language bold and underlined; Deleted language stricken through.]

43 **b. Filing. A declaration of candidacy may be filed with the City Clerk by electronic**
44 **transmission; provided that the original signed and notarized declaration is delivered to**
45 **the City Clerk no later than the close of the filing period. If the City Clerk has not**
46 **received the original signed and notarized declaration before the close of the filing**
47 **period, the candidate's name shall not appear on the ballot.**

48 **c.** Notice. At least one week preceding the candidate filing period, the City Clerk shall
49 publish a notice announcing that candidacy declarations are available, naming offices and
50 the terms that are open on the next regular election day. The notice shall include:

- 51 1. Candidate qualifications.
52 2. Time for filing declarations.
53 3. Where to file declarations.

54 **d.** Declaration. The City Clerk shall provide a form for declaration purposes which will
55 include candidate's name, residence address, mailing address and telephone number; a
56 statement of City residence, voter qualifications and the name of the office and the date of
57 the election to which he declares himself a candidate; the term of office; and a statement of
58 acceptance of the office if elected and an acknowledgment of compliance with the State of
59 Alaska Campaign Disclosure Law. The declaration will be signed and dated by the candidate
60 and sealed by a notary. The candidate's name shall be printed as specified on the declaration
61 for candidacy (see ballot form in HCC 4.15.010 for prohibitions).

62
63 Section 3. Homer City Code 4.35.010, Review of election documents by Canvass
64 Board, is amended to read as follows:

65
66 4.35.010 Review of election documents by Canvass Board.

67 a. The Clerk shall, subject to confirmation of the City Council, appoint a Canvass Board
68 of as many members as required to accomplish the canvass in reasonable time. All members
69 of the election Canvass Board, before entering upon their duties, must subscribe to the oath
70 required of all public officers by the Constitution of the State of Alaska in the manner
71 prescribed by the Clerk. The Canvass Board will review the preliminary certificates of election
72 and all official documents of the precinct election boards and the counting center boards.

73 b. Not later than the Monday following each election, the Canvass Board shall meet in
74 public session and canvass all election returns. The Canvass Board may be recessed from day
75 to day, but not more than three such recesses. In full view of those present, the election
76 Canvass Board shall judge the applicability of absentee and questioned ballots, shall open
77 and tally those accepted, and shall compile the total votes cast in the election. The canvass of
78 ballots counted by the counting center shall be accomplished by reviewing the tallies of the
79 recorded vote to check for mathematical error by comparing totals with the counting center
80 logs and certificates of results. All obvious errors found by the election canvass in the transfer
81 of totals from the precinct tally sheets to the precinct certificate of results shall be corrected
82 by the Canvass Board. A mistake which has been made in precinct returns from the tallies to
83 the certificate of results empowers the Canvass Board to recommend a recount of the results
84 of the precinct or precincts for that portion of the returns in question.

85 c. To be counted in the election, an absentee ballot by mail must be postmarked by
86 midnight of election day and received by the Clerk before the canvass. Envelopes of absentee
87 ballots by mail received after that time shall not be opened, but shall be marked “invalid”
88 with the date and hour of receipt noted thereon, and shall be retained with other ballots of
89 the election. An absentee ballot that is returned by electronic transmission must be received
90 by the Clerk not later than 8:00 p.m. on election day in order to be counted. When the Clerk
91 receives a completed absentee ballot by electronic transmission, the Clerk will remove the
92 ballot portion of the transmission from the portion that identifies the voter; place the ballot
93 portion in a secrecy sleeve and seal the secrecy sleeve; place the sealed secrecy sleeve in an
94 envelope of the type used for absentee ballots returned by mail and seal that envelope;
95 attach the voter identification portion to the outer envelope; and forward the sealed outer
96 envelope to the Canvass Board.

97 d. Questioned and absentee ballots shall be counted as follows: No questioned or
98 absentee ballot by mail shall be counted if the voter has failed to properly execute the
99 certificate, if the witness or the officer or other person authorized by law to administer the
100 oath fails to affix his signature, or if the voter fails to enclose his marked ballot inside the
101 small envelope or secrecy sleeve provided. No absentee ballot by electronic transmission
102 shall be counted if the voter has failed to properly execute the certificate, or if the witness or
103 the officer or other person authorized by law to administer the oath fails to affix his signature.
104 The Clerk or a member of the election Canvass Board may challenge the name of an absentee
105 voter if he has good reason to suspect that the voter is not qualified to vote, is disqualified, or
106 has already voted at the same election. The person making the questioned ballot shall specify
107 the basis of the challenge for the record. The Canvass Board, by majority vote, may refuse to
108 accept the challenge and count the ballot of a person properly challenged. If the ballot is
109 refused, the Clerk shall notify the challenged voter by letter within four weeks of the canvass.
110 All rejected ballots shall be enclosed in a separate envelope and shall be labeled “rejected
111 ballots” retained with other materials of the election. If the ballot is not rejected, the large
112 envelope shall be opened, the small inner envelope or secrecy sleeve shall be placed in a
113 container and mixed with other blank absentee ballot envelopes, or in the case of counting
114 questioned ballots, with other blank questioned-ballot envelopes, the mixed small blank
115 envelopes or secrecy sleeves shall be drawn from the container, opened, and the ballots
116 counted according to the rules of determining properly marked ballots.

117 ~~e. If a tie vote exists and only one of the candidates so tied may hold office under the~~
118 ~~laws establishing the office voted for, the tie shall be broken by a single coin toss conducted~~
119 ~~by the City Council at a regular or special meeting. The first candidate to have filed a~~
120 ~~candidacy declaration shall call the coin during the toss. A tied candidate may designate a~~
121 ~~representative to participate in the coin toss in his absence. The designation shall be made in~~
122 ~~such a manner that the Clerk is assured of its authenticity.~~

123 ~~f. The candidate receiving the required 40 percent and the plurality of the total votes~~
124 ~~cast for his respective office or in the case of a tie winning the coin toss provided at~~
125 ~~subsection (e) of this section shall be determined to have been elected to that office. The~~
126 ~~Council shall certify the results of the election at the next regular or special City Council~~

127 ~~meeting following completion of the canvass by the Canvass Board.~~

128

129 Section 4. Homer City Code 4.35.020, Votes required to be elected, is enacted to read
130 as follows:

131

132 4.35.020 Votes required to be elected. The number of candidates for an office equal to
133 the number of vacancies to be filled who receive the highest number of votes for the office
134 shall be elected, provided that

135 a. To be elected to the office of mayor a candidate must receive more than the
136 plurality of the votes cast for mayor determined by subsection c of this section, and

137 b. To be elected to the council, a candidate must receive more than the plurality
138 determined by subsection c of this section of the total votes cast for all candidates for council
139 divided by the number of seats to be filled.

140 c. The plurality of the vote that is required for a candidate to be elected shall be based
141 on the number of qualified candidates who filed declarations of candidacy that remain in
142 effect on the date of the election as follows:

<u>Number of candidates</u>	<u>Percentage of vote</u>
Less than five	40%
Five or more	35%

146

147 Section 5. Homer City Code 4.35.030, Tie vote, is enacted to read as follows:

148

149 4.35.030 Tie vote. If two candidates tie in receiving the highest number of votes for an
150 office to which only one candidate may be elected, the person to be elected shall be
151 determined by a single coin toss conducted by the City Council at a regular or special
152 meeting. The first candidate to have filed a candidacy declaration shall call the coin during
153 the toss. A tied candidate may designate a representative to participate in the coin toss in his
154 absence. The designation shall be made in such a manner that the Clerk is assured of its
155 authenticity.

156

157 Section 6. Homer City Code 4.35.040, Certification of election, is enacted to read as
158 follows:

159

160 4.35.040 Certification of election. The Council shall certify the results of the election at
161 the next regular Council meeting following completion of the canvass by the Canvass Board.

162

163 Section 7. Homer City Code 4.40.010, Runoff election – Required, is amended to read
164 as follows:

165

166 4.40.010 Runoff election – Required.

167 a. A runoff election shall be held to fill an office that is not filled under HCC 4.35.020 or
168 HCC 4.35.030 at the initial election for the office. ~~If no City Council candidate receives in~~

[Added language bold and underlined: Deleted language stricken through.]

169 ~~excess of 40 percent of the votes cast for a respective seat, a runoff election shall be held.~~
170 ~~When more than one Council seat for the same term is to be filled, total votes cast for a~~
171 ~~respective seat shall be determined by dividing the total number of votes cast for all~~
172 ~~candidates by the number of seats to be filled.~~

173 **b. The two candidates for the office that received the highest number of votes**
174 **without being elected at the initial election shall be the candidates for an office that is to**
175 **be filled by a runoff election.** ~~In the event a runoff is required, the number of candidates~~
176 ~~receiving the highest votes to provide two candidates for each vacancy shall be included in~~
177 ~~the list of candidates for the runoff election.~~

178 **c. If a runoff election for council is required, any candidate who was elected to the**
179 **council at the regular election shall:**

180 **1. Retain the same seat if reelected; or**

181 **2. Succeed a council member whose term is expiring and who was not a**
182 **candidate for reelection.** ~~If no candidate for the office of Mayor receives 40 percent~~
183 ~~of the votes cast for that office, a runoff election between the two candidates receiving~~
184 ~~the highest number of votes will be held.~~

185
186 Section 8. This Ordinance is of a permanent and general character and shall be
187 included in the City Code.

188
189 ENACTED BY THE CITY COUNCIL OF THE CITY OF HOMER, ALASKA, this _____ day of
190 _____ 2016.

191
192 CITY OF HOMER

193
194
195
196 _____
197 MARY E. WYTHE, MAYOR

198 ATTEST:

199
200
201 _____
202 JO JOHNSON, MMC, CITY CLERK

203
204
205 AYES:

206 NOES:

207 ABSTAIN:

208 ABSENT:

209

210

211 First Reading:
212 Public Reading:
213 Second Reading:
214 Effective Date:
215
216
217 Reviewed and approved as to form:
218
219
220 _____
221 Mary K. Koester, City Manager
222
223 Date: _____

Thomas F. Klinkner, City Attorney
Date: _____



City of Homer

www.cityofhomer-ak.gov

Office of the City Clerk

491 East Pioneer Avenue
Homer, Alaska 99603

clerk@cityofhomer-ak.gov

(p) 907-235-3130

(f) 907-235-3143

Memorandum 16-003

TO: MAYOR WYTHE AND HOMER CITY COUNCIL
FROM: JO JOHNSON, CITY CLERK
DATE: JANUARY 4, 2016
SUBJECT: ORDINANCE 16-01 AMENDMENTS TO ELECTION PROCEDURES.

The purpose of Ordinance 16-01 is to clarify election procedures so that the process runs smoothly and is cost effective. The following amendments are made:

2.08.030(a)(b) – A council member or the mayor will remain in office until a successor qualifies. This will leave the Council and Mayor seated until a successor is sworn into office.

2.08.030(c) – Removes the need for a special meeting (and a third meeting in October) for incoming council members and mayor to be sworn in. Mayor and Councilmembers will be sworn in at the first meeting in October following certification of election. The agenda will be amended to move this business to the front of the regular meeting.

4.10.010(a) – Defines the deadline for declaring candidacy if August 15th should fall on a weekend and moves the filing deadline to 4:30 p.m.

4.10.010(b) – Allows a candidate to file declaration of candidacy by electronic transmission, but still requires the original signed and notarized declaration to be filed with the City Clerk before the filing period closes.

4.35.020 – Replaces verbiage in HCC 4.35.010(e) and (f). This defines the percentage of votes required to be elected, and includes percentages of vote required depending on the number of candidates.

4.35.030 – Replaces verbiage in HCC 4.35.010(f) relating to the procedure for a tie vote.

4.35.040 – Replaces verbiage in HCC 4.35.010(f) that the election results will be certified at the next regular council meeting.

4.40.010 – Defines procedure for conducting a runoff election to remove the ambiguity of which candidates participate in a runoff and which council member retains their seat until the runoff is held.

RECOMMENDATION: Introduce Ordinance 16-01 and adopt the amendments to election procedures.

Fiscal Note: N/A

ORDINANCE REFERENCE SHEET
2016 ORDINANCE
ORDINANCE 16-02

An Ordinance of the Homer City Council Amending the 2016 Operating Budget by Appropriating Funds in the Amount of \$20,000 From Port and Harbor Reserves to Purchase Eight Light Emitting Plasma (LEP) Lamps for the Fish Dock.

Sponsor: City Manager/Port and Harbor Director

1. Council Regular Meeting January 11, 2016 Introduction
 - a. Memorandum 16-007 from Port and Harbor Director as backup
 - b. Project Cost Analysis
 - c. BrightLight Systems Specifications

1 **CITY OF HOMER**
2 **HOMER, ALASKA**

3 City Manager/
4 Port and Harbor Director

5 **ORDINANCE 16-02**

6
7 AN ORDINANCE OF THE CITY COUNCIL OF HOMER, ALASKA,
8 AMENDING THE FY 2016 OPERATING BUDGET BY
9 APPROPRIATING FUNDS IN THE AMOUNT OF \$20,000 FROM
10 PORT AND HARBOR RESERVES TO PURCHASE EIGHT LIGHT
11 EMITTING PLASMA (LEP) LAMPS FOR THE FISH DOCK.
12

13 WHEREAS, In an effort to lower energy consumption and reduce operational costs at
14 the harbor, alternative lighting methods for the high mast lights at the Fish Dock were
15 explored; and
16

17 WHEREAS, Harbor personnel tested lighting options over the course of several months
18 and concluded the light emitting plasma (LEP) lamps are better suited for the taller poles on
19 the Fish Dock; and
20

21 WHEREAS, The LEP lamps reduce energy costs in half and their distinctive white light
22 offers the ability to cut through fog and snow; additionally, they produce more useable light
23 on the ground allowing a reduction in the number of fixtures on Fish Dock from 10 to 8 with a
24 cost savings realized within a few years.
25

26 NOW, THEREFORE, THE CITY OF HOMER ORDAINS:
27

28 Section 1. The Homer City Council hereby amends the FY 2016 Operating Budget by
29 appropriating \$20,000.00 from Port and Harbor Reserves for the purchase of eight LEP lamps
30 for the Fish Dock.
31

32 Expenditure:

<u>Account</u>	<u>Description</u>	<u>Amount</u>
456-380	Eight LEP Lamps for the Fish Dock	\$20,000.00



City of Homer

www.cityofhomer-ak.gov

Port and Harbor

4311 Freight Dock Road
Homer, AK 99603

port@cityofhomer-ak.gov

(p) 907-235-3160

(f) 907-235-3152

Memorandum 16-007

TO: MAYOR BETH WYTHE & HOMER CITY COUNCIL
CC: KATIE KOESTER, CITY MANAGER
FROM: BRYAN HAWKINS, PORT DIRECTOR/HARBORMASTER
DATE: DECEMBER 29, 2015
SUBJECT: BUDGET APPROPRIATION FOR FISH DOCK LIGHTING UPGRADE

In 2011, the City of Homer conducted a system-wide energy audit. This led to many upgrade tasks being completed, which in turn led to lowering our overall energy consumption and reducing our operational costs. The high mast lights at the harbor were much discussed during those studies and several recommendations for replacement were researched. At the time it was decided that the technology had not been developed to the point where we felt comfortable spending the dollars needed to make this improvement.

Staff has continued to study high mast security lighting options for our facility, and for the past year we focused our efforts on the fish dock's 75' poles. Basically, we have four light options for these poles; metal halide (our current bulb), high pressure sodium (the orange colored light), LED (light emitting diodes), and LEP (light emitting plasma). Because both the LED and LEP lamps use half as much energy as either the high pressure sodium or the metal halide, we chose to test both lamp types on the dock. After several months of trials, it is our conclusion that the LEPs are better suited for the taller poles like what is on the fish dock. We have had one in place as a test model for over a year without any issues. The new light stands out from the rest because of its distinctive white light coloration. In fact, we are now so confident that these lights put more useable light on the ground that we plan to reduce the overall number of fixtures on the dock from 10 to 8. One of the claims that the LEP lamps offer is their ability to cut through fog and snow, and we can now confirm this claim from our practical product testing.

Staff is also very interested in finding an energy saving option for our 150' high mast light poles. We would like to send out requests for quotes to suppliers to see what options may be out there since we last looked into this subject four years ago. We estimate that our system-wide energy costs for facility lighting is approximately \$80,000 annually. If we could achieve the same level of savings facility-wide as what we'll be seeing at the fish dock, while maintaining the same standards of lighting, then we need to once again, thoroughly investigate our options.

Included is an analysis of the fish dock lighting upgrade, which compares our current 1000 watt fixtures to the new 500 watt Bright Light LEP lamps, and shows a project cost payback of just over two years.

The port commission reviewed this proposal for the fish dock lighting upgrade at their December meeting and asked staff to bring it to the council for funding.

Recommendation: Direct staff to move ahead with purchasing 8 Bright Light Systems light fixtures and installing them on the fish dock facility as soon as possible.

Fiscal Note: Project funding to come from Port and Harbor Reserves Account No. 456-380.

Project: APL, Homer Fish Dock

FIXTURES

Fish Dock

Cost Item	Units	EXISTING	UPGRADE	Fish dock conversion Commentary
		1000 w HID Fish dock	Bright Light Sys BLP1000	
Fixtures Needed	Fixture Quantity	10	8	
Cost per Fixture Delivered	\$ per fixture		\$ 2,500.00	Complete Fixture on Site
Total Cost for Fixtures			\$ 20,000.00	
Facility Installation Cost			\$ -	By Owner
TOTAL Conversion Cost			Total \$ \$ 20,000.00	

Fixture Power Usage	Watts/fixture/hour	1280	540	
Fixture on Hours	hours/day	12	12	Average hours per day
Day per Year of Fixture use	days/year	365	365	Days operation per year
Hours ON	hours/year	4,380	4,380	
KWH/per Fixture/Yr	kWH/year	5,606	2,365	
KWH/per Facility/Yr	kWH/year	56,064	18,922	
KWH Unit Cost	\$/kWH	\$ 0.2400	\$ 0.2400	
Annual Cost of Energy	\$/year	\$ 13,455	\$ 4,541	
<i>Annual Savings</i>			\$ 8,914	Energy Cost Savings, per Year
			66%	% Reduction in Operating Cost

Repair Interval, HID Lamps	hours	15,000	50,000	L70
Repair cost, Lbr & Material: HID	Annual \$	\$ 776	\$ -	Ballast and Lamp
Repair cost, Material: LEP			\$ 600	2 ea LEP Emitter (50,000 HR)
Replacement cost @ 20 years	\$/fixture			
Repair Labor	\$/fixture		\$ 300	By Owner
Annual Repair Cost	\$/year	\$ 776	\$ 630.72	
			\$ 145	Annual Savings on Repair Costs

Annual Operating Cost	\$/year	\$ 14,231	\$ 5,172	
Operating Cost Savings	\$/year		\$ 9,059	
Replacement Payback	years		2.21	

111

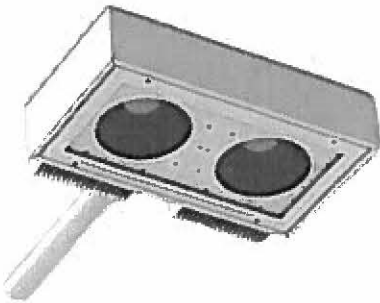
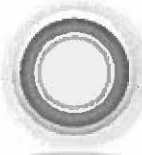

Efficiency. Intelligence. Durability.

Bright Light Systems BLP1000 is the only energy efficient high mast luminaire that utilizes Light Emitting Plasma™ (LEP) to deliver a brilliant white light comparable to daylight with an efficacy that surpasses fluorescent, HID or induction luminaires. Consuming only 540 watts, the BLP1000 distributes light nearly three times more efficiently than a 1000W High Pressure Sodium resulting in increased visibility, safety and security. Intelligently manage lighting performance through integrated wireless controls to further reduce energy costs and increase overall product lifetime. This durable, weatherproof luminaire is ideal for outdoor high mast applications such as ports, parking areas, rail and container yards, airports and highways.

Features

- Reduce Energy Costs by 75%
- Easy Lamp Replacement
- Full Cutoff - Dark Sky Compliant
- Dimmable from 100% to 20%
- Vibration Resistant
- Rated Lifetime of 50,000 Hours
- UL 1598 Listed For Wet Location
- Full Illumination in 60 Seconds
- Wireless Dimming Controls
- 5-Year Limited Warranty

Application

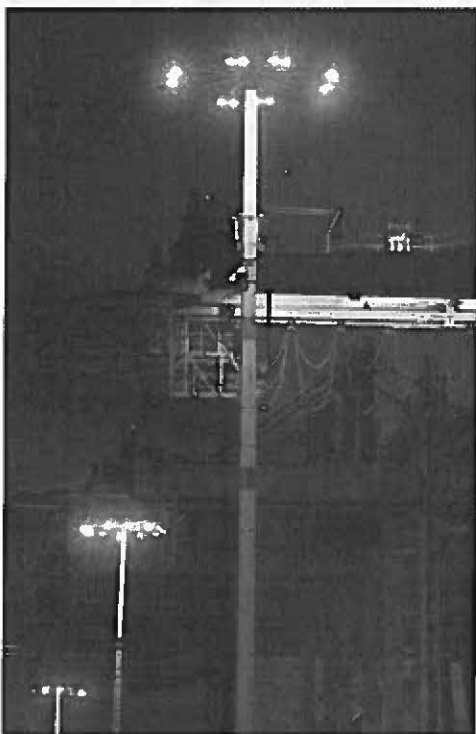

Specifications

• Illumination Source	2 High Powered LEPs (Light Emitting Plasma)
• Power Consumption	540 Watts
• Source Lumens	46,000
• Fixture Lumens	41,000 (Photopic) 98,000 (Visually Effective)
• Optics	Faceted, Die-Formed, High Specular Reflectors
• Distribution	IES Type IV, IES Type V
• Scotopic/Photopic Ratio	2.4
• Dimming Range	20 - 100%
• Protective Lens	3/16" Clear Tempered Glass
• Color Temperature	5,200K
• CRI	75
• Input Voltage	90V - 277V or 347V - 480V 50/60Hz
• Rated Lamp Life (L70)	50,000 Hrs
• Lumen Maintenance	70%
• Finish	Marine Grade Powder Coat w/ UV Inhibitors in Natural
• Construction	Low Copper Content Aluminum
• Cooling	Natural Convection
• Operating Temperature	-40°C to 50°C
• Measurements	26"L x 17"W x 10"H
• Weight	45 lbs (20.4 kg)
• EPA (Windload)	1.54 ft²
• Warranty	5-Year Limited Warranty
• Approvals	UL / cUL 1598 for Wet Location, CE

Additional

All components are UL recognized and rated from -40°C to + 50°C ambient. Luminaire is supplied with two high power factor (>.94) and low THD (<20%) AC/DC power supplies. Built in surge protection offers 10kV suppression in accordance with IEEE/ANSI C62.41.2. Finish passes 1000 hour salt fog test per ASTM B117 and D2247 and is ROHS compliant. Comes with die cast aluminum arm mount with +90 vertical adjustment that fits 2.375" (60mm) O.D. tenon. Designed and manufactured in the USA.



*Specifications subject to change without notice



Dimensions

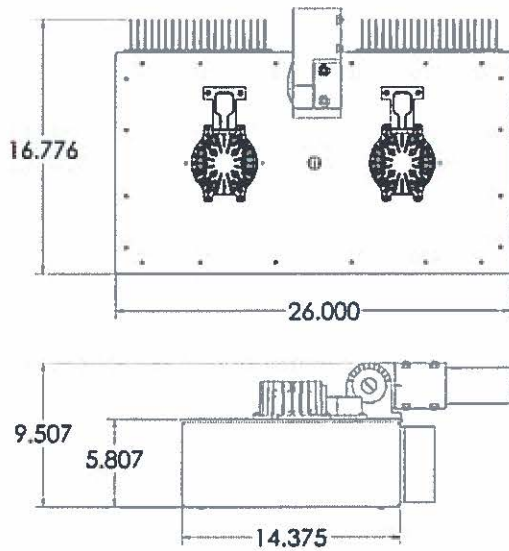

Photometrics

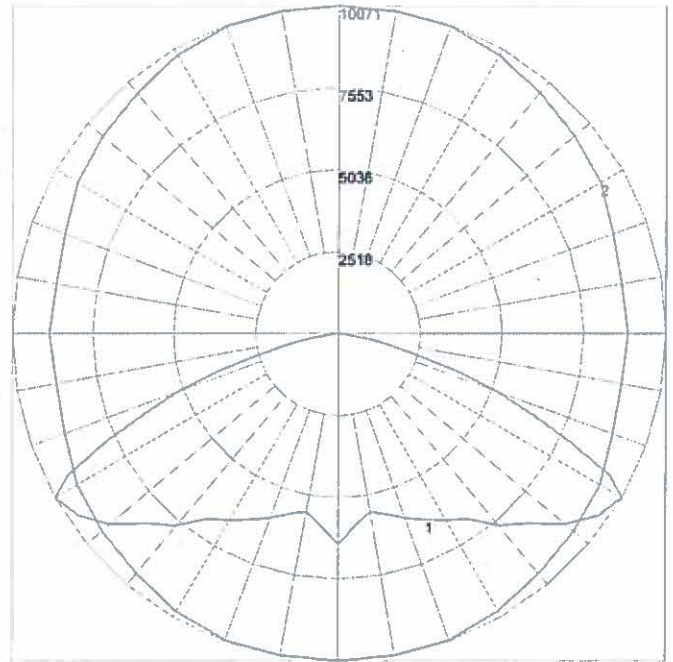

Plot Generated With Nominal STA-41-01 Light Source, Max Candela = 10071
 Located At Horizontal Angle = 90, Vertical Angle = 60
 #1 - Vertical Plane Through Horizontal Angles (90-270) Through Max. Cd.
 #2 - Horizontal Cone Through Vertical Angle (60) Through Max. Cd.

Energy Efficiency

Light Source	1000W HPS	BLP1000
System Wattage	1200W	540W
Daily Usage	12 Hrs	12 Hrs
Annual Energy Consumption	5256 kWh	2365 kWh
Cost per kWh	\$0.12	\$0.12
Annual Operating Cost	\$631	\$284
Rated Lifetime	15,000 Hrs	50,000 Hrs
Replacement Lamps per Year	.29	.09
Maintenance Cost per Lamp	\$300	\$400
Annual Maintenance Cost	\$87	\$36
Total Annual Cost	\$718	\$320
Savings per Fixture		\$398
Estimated Utility Rebate	N/A	\$145
Total Savings per Fixture	N/A	\$543
Savings per Installation	500 units	\$271,500

*Maintenance Cost includes Labor, Lift Expense, Ballast, Etc.
 †Rebate Based on \$1.05 per Annual kWh Saved, Utility Participation Varies
 ‡Use of Wireless Dimming Controller Increases Annual Energy Savings by 30%

BLP1000 vs 1000W HPS



Ordering Information

Product	Lamp	Color Temp	Distribution	EMC	Voltage	Accessories
BLP1000	P1 41-01	52K 5200K	S4 IES Type IV S5 IES Type V	M Mesh N No Mesh	27 110-277V 34 347V 48 480V	WC Wireless Control
Example: BLP1000-P152KS5M48WC				Note: With mesh, luminaire is FCC Part 18 Class A compliant.		

ORDINANCE REFERENCE SHEET
2016 ORDINANCE
ORDINANCE 16-03

An Ordinance of the City Council of Homer, Alaska Amending Ordinance 13-03(S)(2) to State the Actual Principal Amount of, and Change the Payment Dates for, the Natural Gas Distribution Special Assessment Bond Authorized by Ordinance 13-02, and Authorizing an Amendment to the Loan Agreement Between the City and the Kenai Peninsula Borough Regarding the Bond.

Sponsor: City Manager

1. Council Regular Meeting January 11, 2016 Introduction
 - a. Second Amendment to Loan Agreement
 - b. Ordinance 13-02(S)(2)
 - c. Ordinance 13-03(S)(2)

1 **CITY OF HOMER**
2 **HOMER, ALASKA**

3 City Manager

4 **ORDINANCE 16-03**

5
6 AN ORDINANCE OF THE CITY COUNCIL OF HOMER, ALASKA
7 AMENDING ORDINANCE 13-03(S)(2) TO STATE THE ACTUAL
8 PRINCIPAL AMOUNT OF, AND CHANGE THE PAYMENT DATES
9 FOR, THE NATURAL GAS DISTRIBUTION SPECIAL ASSESSMENT
10 BOND AUTHORIZED BY ORDINANCE 13-02, AND AUTHORIZING
11 AN AMENDMENT TO THE LOAN AGREEMENT BETWEEN THE CITY
12 AND THE KENAI PENINSULA BOROUGH REGARDING THE BOND.

13
14 WHEREAS, By Ordinance 13-03(S)(2), adopted February 25, 2013, the City authorized
15 the issuance of a Natural Gas Distribution Special Assessment Bond (“Bond”) in the principal
16 amount of not to exceed \$12,700,000, and the execution and delivery of a Loan Agreement
17 between the City and the Kenai Peninsula Borough (“Borough”) regarding the Bond; and
18

19 WHEREAS, All advances that will be made under the Loan Agreement have been made,
20 the aggregate amount of such advances is \$12,359,388, and such amount may be
21 documented by issuing a new bond to the Borough in exchange for the original Bond; and
22

23 WHEREAS, By Resolution 15-017, adopted March 23, 2015 the City confirmed the
24 assessment roll for the Homer Natural Gas Distribution Special Assessment District
25 (“District”); and
26

27 WHEREAS, Due to delays in the assessment process, the first assessment payments
28 were due on September 1, 2015, and subsequent assessment installment payments will be
29 due on July 1 of each year; and
30

31 WHEREAS, As of the September 1, 2015 assessment payment date, the City had made a
32 payment of principal and interest on the Bond to the Borough from assessment payments
33 received by the City as of that date; and
34

35 WHEREAS, To allow prompter payments under the Loan Agreement the due date for
36 installment payments on the Bond should be changed from April 1 to September 1
37 commencing with the installment payment that is due in 2016.
38

39
40
41
42 NOW, THEREFORE, THE CITY OF HOMER ORDAINS:

43
44
45
46
47
48
49
50
51
52
53
54
55
56
57
58
59
60
61
62
63
64
65
66
67
68
69
70
71
72
73
74
75
76
77
78
79
80
81
82
83
84

Section 1. Section 2 of Ordinance 13-03(S)(2) is amended to read as follows (added language is underlined; deleted language is stricken through):

For the purpose of providing the funds necessary to pay the costs of designing and constructing the Improvement, to pay interest on the Bond during the construction of the Improvement, the funding of the reserves required herein, and to pay all costs incidental thereto and to the issuance of the Bond, the City shall issue the Bond in a principal amount equal to the aggregate amount of the advances that the Registered Owner makes to the City for such purposes, **which is \$12,359,388** ~~but not to exceed \$12,700,000.~~

Section 2. The second paragraph of Section 4 of Ordinance 13-03(S)(2) is amended to read as follows (added language is underlined; deleted language is stricken through):

The Bond shall bear interest from its date at a rate of Four Percent (4.0%) per annum, and shall be payable in two payments of interest only on the 1st days of April 2014 and 2015, **a payment of principal and interest that was received by the Borough as of the September 1, 2015 assessment due date,** and ~~nine~~ **nine** ~~ten~~-equal annual installments of principal and interest, commencing on the 1st day of ~~September~~ **September** ~~April~~-2016 and continuing on ~~September~~ **September** ~~April~~-1 of each year thereafter, until ~~September~~ **September** ~~April~~-1, 2024~~5~~ when the remaining principal balance of the Bond, plus accrued interest, shall be due and payable. Interest will be computed on the basis of a 360-day year consisting of twelve 30-day months.

Section 3. The first paragraph of the form of the bond in Section 7 of Ordinance 13-03(S)(2) is amended to read as follows (added language is underlined; deleted language is stricken through):

The City of Homer (the "City"), a municipal corporation of the State of Alaska, acknowledges itself indebted and for value received promises to pay (but only out of the sources mentioned herein) to the Registered Owner identified above, or its registered assigns, a principal amount equal to the aggregate amount of the advances that the Registered Owner makes to the City to pay the costs of designing and constructing the Improvement, to pay interest on the Bond during the construction of the Improvement, the funding of the reserves required herein, and to pay all costs incidental thereto and to the issuance of the Bond, ~~which is but not to exceed~~ Twelve Million ~~Three Seven~~ **Three** ~~Hundred~~ **Fifty** ~~Nine~~ Thousand **Three Hundred Eighty Eight** Dollars (~~\$12,359,388~~~~12,700,000~~), together with accrued interest on the outstanding principal amount of this Bond at a rate of Four Percent (4.0%) per annum. This Bond is payable in two payments of interest only on the 1st days of April 2014 and 2015, **a payment of principal and interest that was received by the Borough as of the September 1, 2015 assessment due date,** and ~~nine~~ **nine** ~~ten~~-equal annual installments of principal and interest, commencing on the 1st day of ~~September~~ **September** ~~April~~-2016 and continuing on ~~September~~ **September** ~~April~~-1 of each year thereafter, until ~~September~~ **September** ~~April~~-1, 2024~~5~~,

85 when the remaining principal balance of the Bond, plus accrued interest, shall be due and
86 payable. Both principal of and interest on this Bond shall be payable in any lawful money of
87 the United States of America which at the time of payment is legal tender for the payment of
88 public and private debts. Interest on this Bond shall be computed on the basis of a 360-day
89 year consisting of twelve 30-day months. Installments of principal and interest on this Bond
90 shall be paid at the office of the Registered Owner in Soldotna, Alaska, or at the option of the
91 Registered Owner at the office of the Treasurer of the City in Homer, Alaska

92
93 Section 4. The third paragraph of the form of the bond in Section 7 of Ordinance 13-
94 03(S)(2) is amended to read as follows (added language is underlined; deleted language is
95 stricken through):

96
97 This Bond is issued pursuant to Chapter 46, Title 29 of the Alaska Statutes and
98 Ordinance 13-03(S) of the City duly and regularly adopted February 25, 2013, for the purpose
99 of providing funds to pay the costs of designing and constructing a natural gas distribution
100 system (the "Improvement") in the City of Homer Natural Gas Distribution Special
101 Assessment District, and is the single registered Bond entitled \$12,359,388~~12,700,000~~ City of
102 Homer Natural Gas Distribution Special Assessment Bond, 2013.

103
104 Section 5. The amended Bond shall be executed in the name of the City by the
105 signature of the Mayor, and its corporate seal shall be impressed or otherwise reproduced
106 thereon and attested by the signature of the City Clerk.

107
108 Section 6. The City Manager is hereby authorized to execute the Second Amendment
109 to Loan Agreement, in substantially the form presented at this meeting, but with such
110 changes, modifications, additions and deletions therein as she shall deem necessary,
111 desirable or appropriate, the execution thereof to constitute conclusive evidence of approval
112 of any and all changes, modifications, additions or deletions therein from the form and
113 content of said document now before this meeting. The City Manager also is hereby
114 authorized to deliver the amended Bond to the Kenai Peninsula Borough in exchange for the
115 original Bond.

116
117 Section 7. This Ordinance is not permanent in nature, and shall not be codified.

118
119 ENACTED BY THE CITY COUNCIL OF HOMER, ALASKA, this _____ day of
120 _____, 2016.

121
122 CITY OF HOMER

123
124 _____
125 MARY E. WYTHE, MAYOR

126 ATTEST:

127
128
129
130
131
132
133
134
135
136
137
138
139
140
141
142
143
144
145
146
147
148
149
150
151
152
153

JO JOHNSON, MMC, CITY CLERK

YES:
NO:
ABSTAIN:
ABSENT:

First Reading:
Public Hearing:
Second Reading:
Effective Date:

Reviewed and approved as to form.

Mary K. Koester, City Manager

Date: _____

Fiscal Note: NA

Thomas Klinkner, City Attorney

Date: _____

SECOND AMENDMENT TO LOAN AGREEMENT

This SECOND AMENDMENT TO LOAN AGREEMENT (“Amendment”), dated as of January __, 2016, amends the LOAN AGREEMENT (“Loan Agreement”) dated as of March 25, 2013, by and between the KENAI PENINSULA BOROUGH (“Lender”), an Alaska municipal corporation, and the CITY OF HOMER (“Borrower”), an Alaska municipal corporation.

R E C I T A L S

WHEREAS, by Ordinance 13-03(S)(2), adopted February 25, 2013, Borrower authorized the issuance to Lender of a Natural Gas Distribution Special Assessment Bond (“Bond”) in a principal amount equal to the aggregate amount of all advances under the Loan Agreement, but not to exceed \$12,700,000, and the execution and delivery of the Loan Agreement; and

WHEREAS, all Advances that will be made under the Loan Agreement have been made, and the aggregate amount of such advances is \$12,359,388, and such amount may be documented by amending the Loan Agreement; and

WHEREAS, by Resolution 15-017, adopted March 23, 2015, Borrower confirmed the assessment roll for the Homer Natural Gas Distribution Special Assessment District (“District”); and

WHEREAS, due to delays in the assessment process, the first assessment payments were due on September 1, 2015, and subsequent assessment installment payments will be due on July 1 of each year; and

WHEREAS, as of the September 1, 2015 assessment payment date, Borrower made a payment of principal and interest on the Bond to Lender from assessment payments received by Borrower as of that date; and

WHEREAS, to allow prompter payments under the Loan Agreement the due date for installment payments on the Loan should be changed from April 1 to September 1 commencing with the installment payment that is due in 2016.

NOW, THEREFORE, in consideration of the mutual covenants herein, the parties hereto covenant and agree as follows:

Section 1. Section 3.01 of the Loan Agreement is amended to read as follows:

Section 3.01 Loan to Borrower. The Lender hereby makes the Loan to the Borrower in the principal amount of \$12,359,388, which is equal to the aggregate amount of the Advances that the Lender has made to the Borrower under this Loan Agreement. Upon the execution of the Second Amendment to the Loan Agreement, the Borrower shall execute and deliver to the Lender a new

special assessment bond in the form authorized by City of Homer Ordinance 13-03(S) payable to the order of the Lender for the principal amount of the Loan, in exchange for the special assessment bond that the Borrower issued to the Lender at the time of execution of the original Loan Agreement. Thereafter, all references to the Bond herein shall be to such new special assessment bond.

Lender consents to Borrower's amendment of Borrower's Ordinance 13-03(S)(2) to authorize the issuance of an amended Bond with a principal amount conforming to the principal amount stated herein.

Section 2. Section 3.02 of the Loan Agreement is amended to read as follows:

Section 3.02 Payment of Principal and Interest. Borrower shall pay the principal amount of the Loan together with interest on each Advance from the date of the Advance at the rate of Four Percent (4.00%) per annum, in two payments of interest only on the 1st day of April 2014 and 2015, a payment of principal and interest that was received by Lender as of the September 1, 2015 assessment due date, and nine equal annual installments of principal and interest, commencing September 1, 2016 and on each September 1 thereafter until September 1, 2024, when the remaining principal balance of the Loan, plus accrued interest, shall be due and payable. Interest shall be computed on the basis of a 360-day year consisting of twelve 30-day months. Both principal of and interest on the Loan shall be payable in lawful money of the United States of America which at the time of payment is legal tender for the payment of public and private debts. Installments of principal and interest on the Loan shall be payable on the due date in immediately available funds at the principal office of the Lender in Soldotna, Alaska, or at another location specified at the option of the Lender; provided that the final installment of the principal of the Loan, plus accrued interest, shall be payable upon presentation and surrender of the Bond by the Registered Owner at the office of the Registered Owner in Soldotna, Alaska.

Lender consents to Borrower's amendment of Borrower's Ordinance 13-03(S)(2) to authorize the issuance of an amended Bond with payment dates conforming to the amended Loan payment dates herein.

Section 3. Except as expressly amended herein, all terms and conditions of the Loan Agreement as originally executed and previously amended shall remain in full force and effect.

IN WITNESS WHEREOF, the Lender and the Borrower have caused this Amendment to be executed in their respective names all by their duly authorized officers, as of the date first set forth above.

LENDER: KENAI PENINSULA BOROUGH

By: _____
Mike Navarre, Mayor

ATTEST:

Johni Blankenship, Borough Clerk

BORROWER: CITY OF HOMER

By: _____
Mary K. Koester, City Manager

ATTEST:

Jo Johnson, City Clerk

**CITY OF HOMER
HOMER, ALASKA**

City Manager

ORDINANCE 13-02

AN ORDINANCE OF THE CITY COUNCIL OF HOMER,
ALASKA CREATING THE CITY OF HOMER NATURAL
GAS DISTRIBUTION SPECIAL ASSESSMENT DISTRICT,
APPROVING THE IMPROVEMENT PLAN FOR THE
DISTRICT, AND AUTHORIZING THE CITY MANAGER TO
PROCEED WITH THE IMPROVEMENT.

WHEREAS, On July 23, 2012 the Council adopted Resolution 12-069 initiating a special assessment district for a natural gas distribution system in the City; and

WHEREAS, On September 24, 2012, the Council adopted Resolution 12-081 accepting and approving the improvement plan submitted by the City Manager for the proposed natural gas distribution system special assessment district; and

WHEREAS, Notice of a public hearing on the improvement plan has been published at least twice in a newspaper of general circulation in the City, and mailed via certified mail to every record owner of real property in the proposed district not less than 60 days before the hearing; and

WHEREAS, The Council conducted public hearings on the improvement plan on January 14, and January 28, 2013; and

WHEREAS, Owners of real property that would bear 50 percent or more of the assessed cost of the improvement did not file timely written objections to the improvement plan with the City Clerk.

NOW, THEREFORE, THE CITY OF HOMER ORDAINS:

Section 1. The natural gas distribution system in the City that is proposed in the improvement plan will improve the public health, safety and welfare, and is necessary and of benefit to the properties to be assessed.

Section 2. Owners of real property that would bear 50 percent or more of the assessed cost of the improvement did not file timely written objections to the improvement plan with the City Clerk

Section 3. There is hereby created the City of Homer Natural Gas Distribution Special Assessment District (“District”). The improvement that is to be constructed in the District shall be as described in the improvement plan and illustrated in Exhibit B to this ordinance. The properties that are to be assessed for the improvement are described in Exhibit A to this ordinance.

47 Section 4. The estimated cost of the improvement is \$16,875,551. Seventy-five percent
48 (75%) of the cost of the improvement will be assessed against the properties in the District. The
49 estimated amount of the assessments is \$3,283.30 per lot.

50
51 Section 5. The improvement shall be constructed in two phases. Phase I construction
52 shall commence in 2013 and Phase II construction shall commence in 2014. The two phases are
53 illustrated in Exhibit B to this resolution.

54
55 Section 6. The City Manager is authorized to proceed with the improvement, negotiate
56 for the sale of a special assessment bond or other financing for the construction of the
57 improvement for Council approval, and take such other actions that are necessary to accomplish
58 the improvement in accordance with the improvement plan upon financing approval by the
59 Council.

60
61 Section 7. Upon the completion of Phase II of the construction of the improvement, an
62 amount equal to the actual total improvement cost not paid from grant funds, divided by the total
63 number of properties within the District shall be assessed against each property within the
64 District. The City Clerk shall prepare a final assessment roll assessing to each property in the
65 District the amount determined under this section. The proposed assessment roll for the District
66 shall be prepared and presented in accordance with HCC 17.04.070.

67
68 Section 8. The special assessments against properties in the District are liens on those
69 properties and are prior and paramount to all liens except municipal real property tax liens and
70 may be enforced as provided for the enforcement of municipal real property tax liens.

71
72 Section 9. This ordinance is not permanent in nature, and shall not be codified.

73
74 ENACTED BY THE CITY COUNCIL OF HOMER, ALASKA, this 11th day of
75 February, 2013.

76
77 CITY OF HOMER

78
79 Francie W Roberts
80 FRANCIE ROBERTS, MAYOR
81 PRO TEMPORE
82
83
84

85 ATTEST:

86

87

88

89



JO JOHNSON, CMC, CITY CLERK

90

91

YES: 6

92

NO: 6

93

ABSTAIN: 6

94

ABSENT: 6

95

96

First Reading: 1/28/13

97

Public Hearing: 2/11/13

98

Second Reading: 2/11/13

99

Effective Date: 2/12/13

100

101

Reviewed and approved as to form:

102

103

104

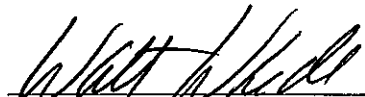

Walt E. Wrede, City Manager

105

106

107

108

Date: 2/14/13



Thomas F. Klinkner, City Attorney

Date: 2-21-13

**CITY OF HOMER
HOMER, ALASKA**

City Manager

ORDINANCE 13-03(S)(2)

AN ORDINANCE OF THE CITY COUNCIL OF HOMER, ALASKA, AUTHORIZING THE CITY TO ISSUE A NATURAL GAS DISTRIBUTION SPECIAL ASSESSMENT BOND IN THE PRINCIPAL AMOUNT OF NOT TO EXCEED \$12,700,000 TO FINANCE THE DESIGN AND CONSTRUCTION OF NATURAL GAS DISTRIBUTION IMPROVEMENTS IN THE CITY, FIXING CERTAIN DETAILS OF SUCH BOND AND AUTHORIZING ITS SALE; AND REPEALING HCC CHAPTER 17.08.

WHEREAS, On February 11, 2013, the Council adopted Ordinance 13-02 creating the City of Homer Natural Gas Distribution Special Assessment District (“District”), and authorizing the City Manager to proceed with the design and construction of a natural gas distribution system in the District (the “Improvement”), and negotiate for the sale of special assessment bonds or other financing for the construction of the Improvement for Council approval; and

WHEREAS, Interim financing for the Improvement is required in anticipation of the levying of special assessments against the real property in the District, and after the levying of the assessments, long-term financing for the Improvement will be required; and

WHEREAS, AS 29.46.130 and AS 29.46.140 authorize the City of Homer “City” respectively to issue notes to obtain interim financing for improvements in a special assessment district, and to issue bonds to obtain long-term financing for improvements in a special assessment district, in each case payable out of special assessments for the improvement, without voter approval; and

WHEREAS, The City Manager has negotiated a Loan Agreement between the Kenai Peninsula Borough (“Lender”) and the City, the form of which is now before this meeting, which provides for the Lender to purchase a bond to finance the Improvement on the terms and conditions set forth therein and in this Ordinance, and it is in the best interest of the City that the City sell the bond to the Lender under such terms and conditions; and

WHEREAS, Homer City Code Chapter 17.08, regarding special assessment bonds, contains terms that are obsolete and conflict with the terms of the financing authorized by this ordinance, and should be repealed.

NOW, THEREFORE, THE CITY OF HOMER ORDAINS:

Section 1 – Definitions. In addition to the terms that are defined in the recitals above, the following terms shall have the following meanings in this Ordinance:

47 "Bond Register" means the registration books maintained by the Registrar as Bond
48 registrar, which include the names and addresses of the owners or nominees of the owners of the
49 Bond.

50
51 "Bond" means the "Natural Gas Distribution Special Assessment Bond, 2013" of the
52 City, the issuance and sale of which are authorized herein.

53
54 "City" means the City of Homer, a municipal corporation of the State of Alaska,
55 organized as a first class city under Title 29 of the Alaska Statutes.

56
57 "Council" means the Council of the City of Homer, as the general legislative authority of
58 the City, as the same shall be duly and regularly constituted from time to time.

59
60 "District" means the Homer Natural Gas Distribution System Special Assessment District
61 created by Ordinance 13-02.

62
63 "ENSTAR" means ENSTAR Natural Gas Company, a division of Semco Energy, Inc., a
64 Michigan corporation.

65
66 "Guaranty Fund" means the fund of that name created by Section 15.

67
68 "Improvement" means the natural gas distribution system to be constructed in the
69 District.

70
71 "Lender" means the Kenai Peninsula Borough, a municipal corporation of the State of
72 Alaska, organized as a second class borough under Title 29 of the Alaska Statutes.

73
74 "Loan Agreement" means the Loan Agreement between the City and the Lender
75 concerning the Bond.

76
77 "Ordinance" means this Ordinance 13-03(S) of the City.

78
79 "Registered Owner" means the person named as the registered owner of a Bond in the
80 Bond Register. The Lender is the initial Registered Owner.

81
82 "Registrar" means the City Treasurer, or any successor that the City may appoint by
83 resolution.

84
85 "Reserve Fund" means the fund of that name created by Section 14.

86
87 "Sinking Fund" means the fund of that name created by Section 13.

88

89 "Special Assessments" means all special assessments to be levied against real property in
90 the District to pay the costs of the Improvement.
91

92 Section 2 – Authorization of Bond and Purpose of Issuance. For the purpose of providing
93 the funds necessary to pay the costs of designing and constructing the Improvement, to pay
94 interest on the Bond during the construction of the Improvement, the funding of the reserves
95 required herein, and to pay all costs incidental thereto and to the issuance of the Bond, the City
96 shall issue the Bond in a principal amount equal to the aggregate amount of the advances that the
97 Registered Owner makes to the City for such purposes, but not to exceed \$12,700,000.
98

99 Section 3 – Obligation of Bond. The Bond is a special obligation of the City and is
100 payable solely from assessments to be levied against the real property in the District for the
101 Improvement, and funds pledged for the payment of the Bond under this Ordinance. Said
102 assessments shall constitute a sinking fund for the payment of principal of and interest on the
103 Bond. Neither the faith and credit nor the taxing power of the City is pledged for the payment of
104 the Bond.
105

106 Section 4 – Description of Bond. The Bond shall be designated "City of Homer Natural
107 Gas Distribution Special Assessment Bond, 2013," shall be issued in fully registered form, and
108 shall be numbered in the manner and with such additional designation as the Registrar deems
109 necessary for purposes of identification, and may have endorsed thereon such legends or text as
110 may be necessary or appropriate to conform to the rules and regulations of any governmental
111 authority or any usage or requirement of law with respect thereto. The Bond shall be dated as of
112 its delivery date.
113

114 The Bond shall bear interest from its date at a rate of Four Percent (4.0%) per annum, and
115 shall be payable in two payments of interest only on the 1st days of April 2014 and 2015, and ten
116 equal annual installments of principal and interest, commencing on the 1st day of April 2016 and
117 continuing on April 1 of each year thereafter, until April 1, 2025, when the remaining principal
118 balance of the Bond, plus accrued interest, shall be due and payable. Interest will be computed
119 on the basis of a 360-day year consisting of twelve 30-day months.
120

121 Section 5 – Optional Redemption. The Bond shall be subject to optional redemption in
122 whole or in part at any time, at a redemption price equal to the principal amount of the Bond to
123 be redeemed plus accrued interest to the date of redemption.
124

125 Section 6 – Notice of Redemption. Notice of any intended redemption of the Bond shall
126 be given not less than 10 nor more than 45 days prior to the date fixed for redemption by first
127 class mail to the Registered Owner of the Bond at its address as it appears on the Bond Register
128 on the day the notice is mailed. The requirements of this section shall be deemed to be complied
129 with when notice is mailed as herein provided, whether or not it is actually received by the
130 Registered Owner. All official notices of redemption shall be dated and shall state the
131 redemption date and the redemption price.

132 Section 7 – Form of Bond. The Bond shall be in substantially the following form, with
133 such variations, omissions and insertions as may be required or permitted by this Ordinance:
134

135 UNITED STATES OF AMERICA
136 STATE OF ALASKA
137 CITY OF HOMER

138
139 No. _____ \$ _____

140
141 NATURAL GAS DISTRIBUTION SPECIAL ASSESSMENT BOND, 2013

142
143 REGISTERED OWNER:

144
145 PRINCIPAL AMOUNT:

146
147 The City of Homer (the “City”), a municipal corporation of the State of Alaska,
148 acknowledges itself indebted and for value received promises to pay (but only out of the sources
149 mentioned herein) to the Registered Owner identified above, or its registered assigns, a principal
150 amount equal to the aggregate amount of the advances that the Registered Owner makes to the
151 City to pay the costs of designing and constructing the Improvement, to pay interest on the Bond
152 during the construction of the Improvement, the funding of the reserves required herein, and to
153 pay all costs incidental thereto and to the issuance of the Bond, but not to exceed Twelve Million
154 Seven Hundred Thousand Dollars (\$12,700,000), together with accrued interest on the
155 outstanding principal amount of this Bond at a rate of Four Percent (4.0%) per annum. This
156 Bond is payable in two payments of interest only on the 1st days of April 2014 and 2015, and ten
157 equal annual installments of principal and interest, commencing on the 1st day of April 2016 and
158 continuing on April 1 of each year thereafter, until April 1, 2025, when the remaining principal
159 balance of the Bond, plus accrued interest, shall be due and payable. Both principal of and
160 interest on this Bond shall be payable in any lawful money of the United States of America
161 which at the time of payment is legal tender for the payment of public and private debts. Interest
162 on this Bond shall be computed on the basis of a 360-day year consisting of twelve 30-day
163 months. Installments of principal and interest on this Bond shall be paid at the office of the
164 Registered Owner in Soldotna, Alaska, or at the option of the Registered Owner at the office of
165 the Treasurer of the City in Homer, Alaska

166
167 This Bond is subject to prepayment by or on behalf of the City, in whole or in part, at any
168 time without penalty, upon notice as provided in the Ordinance referred to below (the
169 “Ordinance”).

170
171 This Bond is issued pursuant to Chapter 46, Title 29 of the Alaska Statutes and Ordinance
172 13-03(S) of the City duly and regularly adopted February 25, 2013, for the purpose of providing
173 funds to pay the costs of designing and constructing a natural gas distribution system (the
174 “Improvement”) in the City of Homer Natural Gas Distribution Special Assessment District, and

175 is the single registered Bond entitled \$12,700,000 City of Homer Natural Gas Distribution
176 Special Assessment Bond, 2013.
177

178 THIS BOND IS PAYABLE SOLELY FROM ASSESSMENTS TO BE LEVIED
179 AGAINST THE REAL PROPERTY IN THE CITY OF HOMER NATURAL GAS
180 DISTRIBUTION SPECIAL ASSESSMENT DISTRICT, AND FUNDS PLEDGED FOR THE
181 PAYMENT OF THE BOND UNDER THE ORDINANCE, AND IS NOT A GENERAL
182 OBLIGATION OF THE CITY, AND NEITHER THE FAITH AND CREDIT NOR THE
183 TAXING POWER OF THE CITY IS PLEDGED FOR ITS REPAYMENT.
184

185 IT IS HEREBY CERTIFIED and declared that this Bond is issued pursuant to and in
186 strict compliance with the Constitution and laws of the State of Alaska and the ordinances of the
187 City of Homer, and that all acts, conditions and things required to happen, to be done and to be
188 performed precedent to and on the issuance of this Bond have happened, been done and been
189 performed.
190

191 IN WITNESS WHEREOF, the City of Homer, Alaska, has caused this Bond to be
192 executed by the signature of its Mayor and attested by its Clerk under the seal of the City on this
193 25th day of ~~March~~, 2013.

February

CITY OF HOMER

Francie Roberts

FRANCIE ROBERTS, MAYOR
PRO TEMPORE

ATTEST:

J. Johnson

JOHNSON, CMC, CITY CLERK

208 Section 8 – Execution. The Bond shall be executed in the name of the City by the
209 signature of the Mayor, and its corporate seal shall be impressed or otherwise reproduced thereon
210 and attested by the signature of the City Clerk. The execution of the Bond on behalf of the City
211 by persons who at the time of the execution are duly authorized to hold the proper offices shall
212 be valid and sufficient for all purposes, although any such person shall have ceased to hold office
213 at the time of delivery of the Bond or shall not have held office on the date of the Bond.
214

215 Section 9 – Payment of Principal and Interest. The Bond shall be payable in lawful
216 money of the United States of America which at the time of payment is legal tender for the
217 payment of public and private debts. Installments of principal and interest on the Bond shall be

218 payable on the due date in immediately available funds at the office of the Registered Owner in
219 Soldotna, Alaska, or at another location specified at the option of the Registered Owner;
220 provided that the final installment of the principal of the Bond, plus accrued interest, shall be
221 payable upon presentation and surrender of the Bond by the Registered Owner at the office of the
222 Registered Owner in Soldotna, Alaska.

223
224 Section 10 – Registration.

225
226 (a) Bond Register. The Bond shall be issued only in registered form as to both
227 principal and interest. The Registrar shall keep, or cause to be kept, a Bond Register at its
228 principal office. The Treasurer of the City is hereby appointed as Registrar and paying agent for
229 the Bond.

230
231 (b) Registered Ownership. The City and the Registrar, each in its discretion, may
232 deem and treat the Registered Owner of the Bond as the absolute owner thereof for all purposes,
233 and neither the City nor the Registrar shall be affected by any notice to the contrary. Payment of
234 the Bond shall be made only as described in Section 9, but such registration may be transferred
235 as herein provided. All such payments made as described in Section 9 shall satisfy and discharge
236 the liability of the City upon the Bond to the extent of the amount or amounts so paid.

237
238 (c) Transfer or Exchange of Registered Ownership. The registered ownership of the
239 Bond may be transferred or exchanged, but no transfer of the Bond shall be valid unless it is
240 surrendered to the Registrar with the assignment form appearing on such Bond duly executed by
241 the Registered Owner or such Registered Owner's duly authorized agent in a manner satisfactory
242 to the Registrar. Upon such surrender, the Registrar shall cancel the surrendered Bond and shall
243 cause to be executed and delivered, without charge to the Registered Owner or transferee, a new
244 Bond (or Bonds at the option of the new Registered Owner) of the same date, maturity and
245 interest rate and for the same aggregate principal amount, naming as Registered Owner the
246 person or persons listed as the assignee on the assignment form appearing on the surrendered and
247 canceled Bond. The Bond may be surrendered to the Registrar and exchanged, without charge,
248 for an equal aggregate principal amount of Bonds of the same date, maturity, and interest rate.
249 The Registrar shall not be obligated to transfer or exchange the Bond following any notice of
250 redemption.

251
252 Section 11 – Lost Stolen, Destroyed or Mutilated Bond. Upon surrender to the Registrar
253 of a mutilated Bond, the City shall execute and deliver a new Bond of like maturity and principal
254 amount. Upon filing with the Registrar of evidence satisfactory to the City that a Bond has been
255 destroyed, stolen or lost and of the ownership thereof, and upon furnishing the City with
256 indemnity satisfactory to it, the City shall execute and deliver a new Bond of like maturity and
257 principal amount. The person requesting the execution and delivery of a new Bond under this
258 section shall comply with such other reasonable regulations as the City may prescribe and pay
259 such expenses as the City may incur in connection therewith.

261 Section 12 – Application of Bond Proceeds. The proceeds of the sale of the Bond shall
262 be applied to pay the costs of designing and constructing the Improvement, including the funding
263 of the reserves required herein, and to pay all costs incidental thereto and to the issuance of the
264 Bond, including without limitation the costs of the Lender as provided in the Loan Agreement,
265 and shall be deposited in the appropriate funds or accounts of the City for such purposes.
266

267 Section 13 – Sinking Fund. A special fund of the City designated the "City of Homer
268 Natural Gas Distribution Special Assessment Bond Sinking Fund" is hereby created for the
269 purpose of paying and securing the payment of the Bond. The Sinking Fund shall be held
270 separate and apart from all other funds and accounts of the City and shall be a trust fund for the
271 Registered Owner of the Bond. Payments of principal and interest on assessments levied for the
272 Improvement in the District shall be deposited in the Sinking Fund. Amounts in the Sinking
273 Fund shall be used to pay principal and interest on the Bond, and are hereby pledged for that
274 purpose. Prepayments of assessments shall be applied to prepay the principal of the Bond, and
275 upon any such prepayment the amortization of the principal of the Bond shall be adjusted so that
276 each remaining scheduled payment of principal and interest on the Bond shall be in an equal
277 amount.
278

279 Section 14 – Reserve Fund.
280

281 (a) A special fund of the City designated the "City of Homer Natural Gas Distribution
282 Special Assessment Bond Reserve Fund" is hereby created for the purpose of paying and
283 securing the payment of the Bond, and is hereby pledged for that purpose. The Reserve Fund
284 shall be held separate and apart from all other funds and accounts of the City and shall be a trust
285 fund for the Registered Owner of the Bond. There shall be paid into the Reserve Fund:
286

287 (1) That part of the proceeds of the Bond which is designated for deposit in
288 the Reserve Fund by the Loan Agreement; and
289

290 (2) All monies received from ENSTAR as refunds of main extension
291 advances or free main allowance arising out of new customers connecting to the
292 Improvement; and
293

294 (3) Any Sinking Fund and Guaranty Fund balances remaining after the
295 discharge of the Bond.
296

297 (b) Until the Bond has been discharged, the funds in the Reserve Fund may be used
298 only to pay the difference between the amount of principal and interest due on the Bond and the
299 amount in the Sinking Fund that is available to pay that principal and interest; provided, if the
300 Finance Director determines that the amount of funds available in the Reserve Fund exceeds the
301 amount of the next annual installment of principal and interest due on the Bond, the Finance
302 Director may apply such excess to a prepayment of the Bond.
303

304 (c) At such time as the Finance Director determines that the sum of the amounts in
305 the Reserve Fund, the Guaranty Fund and the Sinking Fund equals or exceeds the amount
306 required to (i) discharge the Bond, (ii) pay all refunds of assessments required upon discharge of
307 the Bond, and (iii) pay any other amounts that may be owing on the Bond, the Finance Director
308 shall cause such payment to be made and the Bond to be discharged.

309
310 Section 15 – Guaranty Fund. A special fund of the City designated the "City of Homer
311 Natural Gas Distribution Special Assessment Bond Guaranty Fund" is hereby created for the
312 purpose of paying and securing the payment of the Bonds, and is hereby pledged for that
313 purpose. The Guaranty Fund shall be held separate and apart from all other funds and accounts
314 of the City and shall be a trust fund for the Registered Owner of the Bonds. The Council
315 annually shall appropriate to the Guaranty Fund a sum the Council determines to be adequate,
316 with all other available funds, to cover a deficiency in the funds available to pay principal and
317 interest on the Bonds if the reason for the deficiency is nonpayment of assessments when due.
318 Money received from actions taken against property for nonpayment of assessments levied in the
319 District shall be credited to the Guaranty Fund. Amounts in the Guaranty Fund shall be used to
320 pay principal and interest on the Bonds when other funds are not available for that purpose.

321
322 Section 16 – Amendatory and Supplemental Ordinances.

323
324 (a) The Council from time to time and at any time may adopt an Ordinance or
325 Ordinances supplemental hereto, which Ordinance or Ordinances thereafter shall become a part
326 of this Ordinance, for any one or more of the following purposes:

327
328 (1) To add to the covenants and agreements of the City in this Ordinance,
329 other covenants and agreements thereafter to be observed, or to surrender any right or
330 power herein reserved to or conferred upon the City.

331
332 (2) To make such provisions for the purpose of curing any ambiguities or of
333 curing, correcting or supplementing any defective provision contained in this Ordinance
334 or in regard to matters or questions arising under this Ordinance as the Council may deem
335 necessary or desirable and not inconsistent with this Ordinance and which shall not
336 adversely affect the interests of the Registered Owner of the Bond.

337
338 Any such supplemental Ordinance may be adopted without the consent of the Registered
339 Owner of the Bond, notwithstanding any of the provisions of subsection (b) of this section.

340
341 (b) With the consent of the Registered Owners of not less than 60 percent in
342 aggregate principal amount of the Bond at the time outstanding, the Council may adopt an
343 Ordinance or Ordinances supplemental hereto for the purpose of adding any provisions to or
344 changing in any manner or eliminating any of the provisions of this Ordinance or of any
345 supplemental Ordinance; provided, however, that no such supplemental Ordinance shall:

346

347 (1) Extend the due date of any principal installment payable under the Bond,
348 or reduce the rate of interest thereon, or extend the time of payments of interest from their
349 due date, or reduce the amount of the principal thereof, or reduce any premium payable
350 on the redemption thereof, without the consent of the Registered Owners of all of the
351 Bond so affected; or

352
353 (2) Reduce the aforesaid percentage of Registered Owners of the Bond
354 required to approve any such supplemental Ordinance without the consent of the
355 Registered Owners of all of the Bond then outstanding.

356
357 (3) Remove the pledge and lien of this Ordinance on assessments to be levied
358 against the real property in the District, and funds pledged for the payment of the Bond
359 under this Ordinance.

360
361 It shall not be necessary for the consent of the Registered Owner of the Bond under this
362 subsection (b) to approve the particular form of any proposed supplemental Ordinance, but it
363 shall be sufficient if such consent shall approve the substance thereof.

364
365 (c) Upon the adoption of any supplemental Ordinance pursuant to the provisions of
366 this section, this Ordinance shall be deemed to be modified and amended in accordance
367 therewith, and the respective rights, duties and obligations under this Ordinance of the City and
368 the Registered Owner of the Bond shall thereafter be determined, exercised and enforced
369 thereunder, subject in all respects to such modification and amendment, and all the terms and
370 conditions of any such supplemental Ordinance shall be deemed to be part of the terms and
371 conditions of this Ordinance for any and all purposes.

372
373 (d) Any Bond executed and delivered after the adoption of any supplemental
374 Ordinance pursuant to this section may bear a notation as to any matter provided for in the
375 supplemental Ordinance, and if the supplemental Ordinance shall so provide, a new Bond so
376 modified as to conform, in the opinion of the Council, to any modification of this Ordinance
377 contained in any such supplemental Ordinance may be prepared by the City and delivered
378 without cost to the Registered Owner of the Bond then outstanding, upon surrender for
379 cancellation of such Bond in an equal aggregate principal amount.

380
381 Section 17 – Sale of Bond; Loan Agreement. The Bond shall be sold at negotiated sale to
382 the Lender as provided in the Loan Agreement. The City Manager is hereby authorized to
383 execute the Loan Agreement, in substantially the form presented at this meeting, but with such
384 changes, modifications, additions and deletions therein as he shall deem necessary, desirable or
385 appropriate, the execution thereof to constitute conclusive evidence of approval of any and all
386 changes, modifications, additions or deletions therein from the form and content of said
387 document now before this meeting, and from and after the execution and delivery of said
388 document, the City Manager hereby is authorized, empowered and directed to do all acts and
389 things and to execute all documents as may be necessary to carry out and comply with the

390 provisions of the Loan Agreement as executed. Upon the execution of the Loan Agreement, the
391 City shall execute and deliver the Bond to the Borough in the form authorized herein.
392

393 Section 18 – Authority of Officers. The City Manager, the acting City Manager, the
394 Clerk and the acting Clerk are, and each of them hereby is, authorized and directed to do and
395 perform all things and determine all matters not determined by this Ordinance, to the end that the
396 City may carry out its obligations under the Bond and this Ordinance.
397

398 Section 19 – Miscellaneous. No recourse shall be had for the payment of the principal of
399 or the interest on the Bond or for any claim based thereon or on this Ordinance against any
400 member of the Council or officer of the City or any person executing the Bond.
401

402 Section 20 – Ordinance a Contract with Registered Owner. In consideration of the
403 purchase and acceptance of the Bond by those who shall own the same from time to time, the
404 provisions of this Ordinance shall constitute a contract with the Registered Owners of each
405 Bond, and the obligations of the City under this Ordinance shall be enforceable by any court of
406 competent jurisdiction; and the covenants and agreements herein set forth to be performed on
407 behalf of the City shall be for the equal benefit, protection and security of the Registered Owners
408 of any and all of the Bond.
409

410 Section 21 – Severability. If any one or more of the provisions of this Ordinance shall be
411 declared by any court of competent jurisdiction to be contrary to law, then such provision shall
412 be null and void and shall be deemed separable from the remaining provisions of this Ordinance
413 and shall in no way affect the validity of the other provisions of this Ordinance or of the Bond.
414

415 Section 22 – Repeal of HCC 17.08. HCC Chapter 17.08 is repealed.
416

417 Section 23 – Codification. Section 22 of this Ordinance is of a permanent and
418 general character and shall be included in the City Code. The remainder of this Ordinance
419 is not permanent in nature, and shall not be codified.
420

421 ENACTED BY THE CITY COUNCIL OF HOMER, ALASKA, this 25th day of
422 February 2013.
423

424 CITY OF HOMER

425
426 
427 _____
428 FRANCIE ROBERTS, MAYOR
429 PRO TEMPORE
430



431 ATTEST:

432

433

434

435

436

437

438

439

440

441

442

443

444

445

446

447

448

449

450

451

452

453

454

JO JOHNSON, CMC, CITY CLERK

YES: 6

NO: 0

ABSTAIN: 0

ABSENT: 0

First Reading: 1/28/13
Public Hearing: 2/11/13 @ 2/25/13
Second Reading: 2/25/13
Effective Date: 2/26/13

Reviewed and approved as to form:

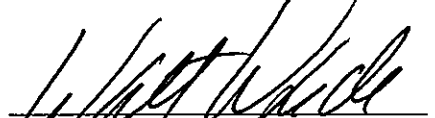
Walt E. Wrede, City Manager

Thomas F. Klinkner, City Attorney

Date: 2/26/13

Date: _____

**CITY OF HOMER
HOMER, ALASKA**

City Manager

RESOLUTION 16-001

A RESOLUTION OF THE HOMER CITY COUNCIL CONFIRMING THE CITY MANAGER'S APPOINTMENT OF JO JOHNSON AS THE ACTING CITY MANAGER AND MARK ROBL AS BACKUP ACTING CITY MANAGER FOR CALENDAR YEAR 2016.

WHEREAS, Homer City Code 1.20.010(b) states that the City Manager shall annually appoint an Acting City Manager, subject to the City Council confirmation which is revocable at any time, by the Council; and

WHEREAS, Pursuant to Homer City Code Section 1.20.010(b) the Acting City Manager shall assume the duties and powers of the City Manager in their absence.

NOW, THEREFORE, BE IT RESOLVED by the Homer City Council that Jo Johnson is hereby appointed by City Manager Katie Koester and confirmed by the Homer City Council as Acting City Manager for the Calendar Year 2016.

BE IT FURTHER RESOLVED that Mark Robl is hereby appointed by City Manager Katie Koester and confirmed by the Homer City Council as the backup Acting City Manager for the Calendar Year 2016.

PASSED AND ADOPTED by the City Council of Homer, Alaska, this 11th day of January, 2016.

CITY OF HOMER

MARY E. WYTHE, MAYOR

ATTEST:

JO JOHNSON, MMC, CITY CLERK

Fiscal Note: N/A

**CITY OF HOMER
HOMER, ALASKA**

City Manager

RESOLUTION 16-002

A RESOLUTION OF THE HOMER CITY COUNCIL CONFIRMING THE APPOINTMENTS OF ZHIYONG LI AS TREASURER AND JENNA DELUMEAU AS DEPUTY TREASURER FOR CALENDAR YEAR 2016.

WHEREAS, Homer City Code §1.34.010 states that the Treasurer and Deputy Treasurer shall be appointed by and serve at the pleasure of the City Manager, that the Treasurer and Deputy Treasurer shall be confirmed by the Council annually during the first meeting in January and whenever the appointment becomes vacant or whenever the City Manager deems it appropriate to change the appointment; and

WHEREAS, Pursuant to HCC §1.34.010, City Manager Katie Koester hereby provides notice of the appointment of Zhiyong Li as Treasurer and Jenna deLumeau as Deputy Treasurer for Calendar Year 2016.

NOW, THEREFORE, BE IT RESOLVED that the City Council of Homer, Alaska, confirms the appointments of Zhiyong Li as Treasurer and Jenna deLumeau as Deputy Treasurer for the Calendar Year 2016.

PASSED AND ADOPTED by the Homer City Council this 11th day of January, 2016.

CITY OF HOMER

MARY E. WYTHE, MAYOR

ATTEST:

JO JOHNSON, MMC, CITY CLERK

Fiscal Note: N/A

1 **CITY OF HOMER**
2 **HOMER, ALASKA**

3 City Clerk

4 **RESOLUTION 16-003**

5
6 A RESOLUTION OF THE HOMER CITY COUNCIL ACKNOWLEDGING
7 THE NOVEMBER 2015 SURPLUS EQUIPMENT BID RESULTS.

8
9 WHEREAS, A Surplus Personal Property Sale was conducted in accordance with Homer
10 City Code 18.30; and

11
12 WHEREAS, The November 2015 Surplus Equipment Sale Invitation to Bid was
13 advertised in the Homer Tribune on November 25 and December 3, 2015 and posted on the
14 City of Homer website; and

15
16 WHEREAS, Sealed bids were due by 3:00 p.m. on Thursday, December 10, 2015; and

17
18 WHEREAS, There were 64 items on the surplus equipment list; and

19
20 WHEREAS, 22 bidders submitted a total of 79 bids on 30 of the items available for sale;
21 and

22
23 WHEREAS, The City Manager shall reevaluate the value of the items not bid upon and if
24 found to meet the criteria of Homer City Code 18.30.040, the City Manager may authorize the
25 disposal of items through non-competitive bidding.

26
27 NOW, THEREFORE, BE IT RESOLVED the the City Council of Homer, Alaska, hereby
28 acknowledges the surplus equipment bid results, attached as Exhibit A.

29
30 PASSED AND ADOPTED by the Homer City Council this 11th day of January, 2016.

31
32 CITY OF HOMER

33
34
35 _____
36 MARY E. WYTHE, MAYOR
37
38

39 ATTEST:

40

41

42 _____

43 JO JOHNSON, MMC, CITY CLERK

44

45

46 Fiscal Note: Cost of advertising and processing bids. Generated revenue of \$7,836.11

47 distributed to the appropriate accounts.

**SURPLUS EQUIPMENT BID RESULTS
NOVEMBER 2015 SURPLUS EQUIPMENT SALE**

ITEM #	NAME	DESCRIPTION	MIN BID	
PH 01	Boat Trailer (14-3)	Quad Axle, 24' Homemade, Steel Tube Frame, (No Plate)	\$100.00	
PH 02	Boat Trailer (14-4)	Single Axle, 20' Escort, Galvanized Steel (4205 PM)	\$200.00	Jones \$276 Morrison \$222
PH 03	Boat Trailer (14-16)	Single Axle, 20' Homemade, Steel Frame, (3643 RR)	\$100.00	Olsen \$130
PH 04	Outboard Engine & Spare Lower Unit	2002, 90HP Honda O/B Engine, 25" Shaft, Carbureted, Honda 25" Shaft Used Lower Unit for 90HP O/B	\$500.00	Jones \$581 Riley \$525 Lyon \$560
PH 05	Fuel Tank & Stand	300 Gallon Steel Heating Fuel Tank on 6' Steel Stand		Moyer \$101.99 Worland \$200 Jones \$75 1st Class \$100 RMorris \$89 Zelinski \$50 Riley \$35
PH 06	Shed Building	8'LX8'WX10'H T1-11 Wood Building, Set On Skids		Tesch \$425 1st Class \$100 Rmorris \$119 Zelinski \$111 JMorris \$126 Symens \$2.55 Chapple \$326
PH 07	Ice Delivery system	Pneumatic ice delivery system, blower and motor, rotary valve, heat exchanger, diverter valves, 330' aluminum 5" pipe, 20' aluminum 6" pipe, assorted fittings, etc.		
PH 08	Commercial Outriggers	2 each, 20' X 3" Aluminum Pipe, 3", Rigging and Divers		Moss \$30 Riley \$6
PH 09	Electrical Service Stand	30 each, Sangamo Watt/Hour Meter, CL200, 240V, 3-Wire, Type J4s, 30 & 50 Amp Receptacles, Set On 4' Steel Stands		Home Run Oil \$750
PH 10	Electrical Service Stand	8 each, Shallbetter 100 Amp, 208V, Type 3R Enclosure, 60 Amp Receptacle, Set on 56" Tall, 6" Square Galv. Tube		
PH 11	Cooler	Igloo Cooler, 100 Quart, Used	\$5.00	Raymond \$12
PH 12	Cut Off Saw	Dewalt DW-871 Bench Mount Saw	\$25.00	Moss \$30 Box \$32.99 Raymond \$30
PH 13	Smart Ash Burner	3 each, Elastec Smart Ash Burner Sized for 50 Gallon Drum		
PH 14	Used Oil Burner	Used Oil Burner Unit		

PH 15	Toyo Stove	Toyo Stove, Model Laser 73 & Exhaust Kit	\$100.00	Box \$219.09 Moyer \$119 Balland \$157.93 Olsen \$175 Zelinski \$415 Jones\$252 1st Class \$300 Riley \$165
PH 16	Dry Air Unit	Johnson Control Dry Flow, Aircompressor Supply Drying Unit, Model A-4312-1		Home Run Oil \$25
PH 17	VHF Marine Radio	Raytheon, Ray 53 VHF Radio. Used. No Mounts or Wires.		
PW 1	E156 Dump Truck	1982 Ford 10 yd End Dump Truck, Good eng, Frame issues	\$500	R Morris \$577
PW 2	E158 Chevy Flatbed	1966 Chevy Flatbed 2-ton truck - Good engine, Runs	\$500	
PW 3	E292 Boss V Snow Plow	2002 Boss V-Plow with mounts and controls	\$500	Box \$602.99 Robl \$1379 Welty\$723 1st Class \$700
PW 4	E425 Ford F250 2x4 Truck	1990 Ford F250 2x4 Pickup Truck		Zelinski \$145 R Morris \$17 Symens \$29.29
PW 5	Diazit Blue-Line Machine	Diazit ammonia Blue-Line machine for copying mylar drawings		
PW 6	E258 Air Compressor	80 gal. commercial air compressor - 27 yr old, not working		Symens \$1
PW 7	Backhoe Bucket	Wide bucket for rubber-tired hoe		Martin Constr \$50 R Morris \$27 Symens \$12.13
PW 8	360 LF of 3" HDPE	360 lineal feet of 3" HDPE in 40' sticks		Home Run Oil \$100 Martin Consr \$50 R Morris \$77 J Morris \$37
PW 9	Truck Hitch	Truck Receiver Hitch Assembly		
PW 10	Plastic Trail Sections	Approx. 150 lineal feet of floats & plastic trail sections		Home Run Oil \$125 Robl \$51 Welty \$160 Jones \$250 Raymond \$500 Chapple \$2111
PW 11	Paint Striping Machine	Walk-Behind Paint Striper - Compression Operation		Home Run Oil \$10
PW 12	NSS Wide Vacuum Machine	NSS Wide Commercial Vacuum Machine		

PW 13	Modine Shop Heater	Modine Propane Shop Heater		Tesch \$65 Raymond \$15 Riley \$15
PW 14	Reznor Shop Heater	Reznor Propane Shop Heater		Raymond \$15 Zelinski \$20 Symens \$3.30 Riley \$3
PW 15	Forklift Forks	Forklift Forks		Martin Constr \$50 R Morris \$11 Symens \$15.15
PW 16	Power Flame Oil Burner	Power Flame Oil Burner		Raymond \$15 Riley \$5
PW 17	Chairs	8 Padded Chairs with Arms - Sold as one unit		Robl \$11
PW 18	Chairs	1 Padded Chair without arms		
PW 19	Chair	Black Desk Chair with wheels no arms		
PW 20	Chairs	Two padded chairs with arms		
PW 21	Desk	Black Metal Desk		
CH 02	Desk	Black Metal w/Return		
CH 18	Table	Wood with Wheels		
CH 26	Digital Camera	Sony Digital Maciva Camera with Case		
CH 28	TV	JVC 13" with VCR & Remote		
CH 29	TV	Toshiba 27"(?) with Remote		
CH 30	TV	Panasonic 13"		
CH 31	TV	Symphonic 13"		
CH 32	VCR	Zenith with Remote		

CH 33	Typewriter	IBM Wheel Writer		
CH 34	Desk	Black Metal 5 drawers		
CH 35	Desk	Wood 4 Drawers- missing return		Robl \$11
CH 36	Desk	Wood		
CH 37	Table	Wood Conference Table		
CH 41	Desk	Black Metal with Return		
CH 56	Table	Tan Metal Desk Table		
CH 57	Printer/Copy Cartridges	Various HP and Xerox Printer/Copier Cartridges		
CH 60	Computer Desk	Wood with wheels		
CH 61	Table	Wood		
CH 62	Cassette Tape Reformatter	Cassette Tape Reformatter		
CH 63	Cassette Tape Reformatter	Cassette Tape Reformatter		Riley \$1.50
CH 64	Filing Cabinet	Black 4 Drawer		Robl \$11
CH 65	Kiosks	Two metal		
CH 66	Partitions	5 Wall Partitions - assorted sizes and colors		
LIB 01	Typewriter	IBM Wheel Writer		
LIB 02	Typewriter	IBM Wheel Writer		

LIB 03	Typewriter	Brother		
--------	------------	---------	--	--

1 **CITY OF HOMER**
2 **HOMER, ALASKA**

3 City Manager

4 **RESOLUTION 16-004**

5
6 A RESOLUTION OF THE CITY COUNCIL OF HOMER, ALASKA,
7 AUTHORIZING THE CITY MANAGER TO DISPOSE OF USED AND
8 SURPLUS EQUIPMENT PURSUANT TO HCC 18.30.010 AND HCC
9 18.30.040(B).

10
11 WHEREAS, The City conducted a surplus equipment sale on December 10, 2015 and
12 several of the items did not sell; and

13
14 WHEREAS, A number of obsolete items remain in storage at the HERC and HERC 2
15 buildings; and

16
17 WHEREAS, The items are unneeded and surplus pursuant to HCC 18.30.010; and

18
19 WHEREAS, HCC 18.30.040(b) provides that “the City Manager may sell, lease, donate,
20 exchange or otherwise dispose of personal property, or an interest therein, to or with another
21 municipality, state, or the United States when and under such terms and conditions as the
22 City Council, in its sole judgment, deems advantageous to the City to do so.”; and

23
24 WHEREAS, The City Manager would like to offer the remaining surplus items to non-
25 profit organizations or entities in need of the equipment and to make needed space.

26
27 NOW, THEREFORE, BE IT RESOLVED that the Homer City Council hereby declares the
28 remaining used and surplus equipment to be unneeded and surplus and authorizes the City
29 Manager to dispose of it pursuant to either HCC 18.30.010 and HCC 18.30.040(b) in the best
30 interests of the City.

31
32 PASSED AND ADOPTED by the Homer City Council this 11th day of January, 2016.

33
34 CITY OF HOMER

35
36 _____
37 MARY E. WYTHE, MAYOR

38 ATTEST:

39

40

41 _____

42 JO JOHNSON, MMC, CITY CLERK

43

44 Fiscal Note: Revenue amount to be determined.

45

SURPLUS EQUIPMENT REMAINING AT THE HERC AND HERC II LOCATIONS

ITEM #	NAME	DESCRIPTION		
PW 18	Chairs	1 Padded Chair without arms		
PW 19	Chair	Black Desk Chair with wheels no arms		
PW 20	Chairs	Two padded chairs with arms		
PW 21	Desk	Black Metal Desk		
CH 02	Desk	Black Metal w/Return		
CH 18	Table	Wood with Wheels		
CH 26	Digital Camera	Sony Digital Maciva Camera with Case		
CH 28	TV	JVC 13" with VCR & Remote		
CH 29	TV	Toshiba 27"(?) with Remote		
CH 30	TV	Panasonic 13"		
CH 31	TV	Symphonic 13"		
CH 32	VCR	Zenith with Remote		
CH 33	Typewriter	IBM Wheel Writer		
CH 34	Desk	Black Metal 5 drawers		
CH 36	Desk	Wood		
CH 37	Table	Wood Conference Table		

SURPLUS EQUIPMENT REMAINING AT THE HERC AND HERC II LOCATIONS

CH 41	Desk	Black Metal with Return		
CH 56	Table	Tan Metal Desk Table		
CH 57	Printer/Copy Cartridges	Various HP and Xerox Printer/Copier Cartridges		
CH 60	Computer Desk	Wood with wheels		
CH 61	Table	Wood		
CH 62	Cassette Tape Reformatter	Cassette Tape Reformatter		
CH 65	Kiosks	Two metal		
CH 66	Partitions	5 Wall Partitions - assorted sizes and colors		
LIB 01	Typewriter	IBM Wheel Writer		
LIB 02	Typewriter	IBM Wheel Writer		
LIB 03	Typewriter	Brother		



City of Homer

www.cityofhomer-ak.gov

Office of the City Manager

491 East Pioneer Avenue
Homer, Alaska 99603

citymanager@cityofhomer-ak.gov

(p) 907-235-8121 x2222

(f) 907-235-3148

Memorandum 16-009

TO: Mayor Wythe and Homer City Council
FROM: Katie Koester, City Manager
DATE: January 6, 2016
SUBJECT: Surplus Sale and Spring Cleaning

Resolutions 16-003 and 16-004 authorize the City Manager to dispose of used and surplus equipment. The City has a number of office items – primarily furniture – from before the remodel of City Hall. Many of these items have little value, are currently stored upstairs at the HERC, and have been included in a surplus sale multiple times. In an effort to get these items to a useful home and do a little first of the year cleaning, I will set a date for area nonprofits to come pick up the items free of charge on a first come first serve basis. The Homer Foundation has a list of area nonprofits and sends out a monthly call for nonprofit needs that the City can use to let people know. Any items that are not picked up by then will be brought to the transfer site, where I am sure in true Homer style they will get picked over again.

**CITY OF HOMER
HOMER, ALASKA**

City Manager

RESOLUTION 16-005

A RESOLUTION OF THE HOMER CITY COUNCIL EXCLUDING KENAI PENINSULA BOROUGH PARCEL 17708014 OWNED BY COOK INLET REGION, INC. FROM THE HOMER NATURAL GAS SPECIAL ASSESSMENT DISTRICT.

WHEREAS, Cook Inlet Region, Inc. ("CIRI") owns the parcel described below ("Property"), and has objected to the assessment of the Property for natural gas distribution improvements:

KPB Parcel 17708014
Legal Description: T6S R13W Sec 20 S.M. HM 09300008 Homer FAA Site Subdivision Tract 37A Homer Recording District

WHEREAS, CIRI acquired the Property under the Alaska Native Claims Settlement Act ("ANCSA"), which exempts such property from assessment if it is undeveloped, and the Property is undeveloped; and

WHEREAS, Because the Property is exempt from assessment under ANCSA, it should be excluded from the Homer Natural Gas Distribution Special Assessment District.

NOW, THEREFORE, BE IT RESOLVED that the following property shall be excluded from the Homer Natural Gas Distribution Special Assessment District:

KPB Parcel 17708014
Legal Description: T6S R13W Sec 20 S.M. HM 09300008 Homer FAA Site Subdivision Tract 37A Homer Recording District

BE IT FURTHER RESOLVED that the City Clerk shall record this resolution in the Homer Recording District.

PASSED AND ADOPTED by the Homer City Council this 11th day of January, 2016.

CITY OF HOMER

MARY E. WYTHER, MAYOR

44 ATTEST:

45

46

47

48 _____
JO JOHNSON, MMC, CITY CLERK

49

50 Fiscal Note: \$3,262.77 reduction from Homer Natural Gas Special Assessment District Account
51 No. 175-0375.



May 26, 2015

Jo Johnson, City Clerk
City of Homer
Finance Department
491 East Pioneer Ave
Homer AK 99603

Re: Homer Natural Gas Special Assessment District property assessments
PARCEL NUMBERS: 17715212, 17715104, 17708019, 17708014, 17708008,
17708005

Dear Ms. Johnson,

Cook Inlet Region, Inc. (CIRI) is in receipt of six property assessments for the Homer Natural Gas Special Assessment District (HSAD).

Under the Alaska Native Claims Settlement ACT (ANCSA) as amended, ANCSA property is exempt from real property taxes by any governmental entity until it is developed, furthermore, ANCSA amendment P.L. 100-241, specifically states that providing utilities shall not constitute development. CIRI received parcel 17708014 through ANCSA which is currently undeveloped and therefore exempt from taxation. The HSAD is a form of taxation, which cannot be applied to CIRI's undeveloped property therefore an assessment payment will not be submitted for this parcel.

Five parcels (17715212, 17715104, 17708008, 1770819, and 17708005) are within the City Council of Homer's approved Special Assessment District and are considered taxable. Payment for the assessments are enclosed.
Thank you for your attention to this matter.

Sincerely,

Jason W. Brune
CIRI, Sr. Director of Land and Resources

Enc. Check for Assessment Payment



Birch Horton Bittner & Cherot

a professional corporation

Thomas F. Klinkner

Respond to Anchorage Office
T 907.263.7219 • F 907.276.3680
tklinkner@bhb.com

July 24, 2015

Mr. Jason W. Brune
Sr. Director of Land and Resources
Cook Inlet Region, Inc.
2525 C Street, Suite 500
Anchorage, AK 99503

RE: City of Homer
Natural Gas Assessment for Parcel No. 17708014
Our File No.: 506,742.205

Dear Mr. Brune:

This responds to your letter of May 26, 2015, to Homer City Clerk Jo Johnson regarding the exemption of the parcel referred to above from assessment in the Homer Natural Gas Distribution Special Assessment District ("District").

The City questions whether the claim of Cook Inlet Region, Inc. ("CIRI"), for exemption from assessment in the District was timely. Assessments in the District were confirmed by the City Council by the adoption of Resolution 15-017 on March 23, 2015, after public hearings on that date and on March 16, 2015. AS 29.46.120 provides:

Sec. 29.46.120. Objection and appeal.

(a) The validity of an assessment may not be contested by a person who did not file with the municipal clerk a written objection to the assessment roll before its confirmation.

(b) The decision of the governing body on an objection may be appealed to the superior court within 30 days after the date of confirmation of the assessment roll. If no objection is filed or appeal taken within that time, the assessment procedure is considered valid in all respects.

Language to the same effect appears in Homer City Code 17.04.130.

The City's records do not show that CIRI filed a written objection to the assessment with the City Clerk before its confirmation, and CIRI did not appeal the assessment to the superior court within 30 days after the confirmation of the assessment roll. Case authority establishes that claims for exemption from taxation under ANCSA for undeveloped land are waived if not

asserted in a timely manner under state statutes and municipal ordinances.¹ Thus, it appears that CIRI's claim of exemption is barred by AS 29.46.120.

If CIRI believes that the analysis above is either factually or legally incorrect, I would appreciate your providing a written explanation of that belief, accompanied by documentation and legal authorities.

Yours truly,

BIRCH HORTON BITTNER & CHEROT



Thomas F. Klinkner

TFK:lcj

cc: Mary K. Koester

F:\506742\205\00461497.DOCX

¹ *Kenai Peninsula Borough v. Cook Inlet Region, Inc.* 807 P.2d 487, 491-492 (Alaska 1991); *Kenai Peninsula Borough v. Port Graham Corp.*, 871 P.2d 1135, 1138-1139 (Alaska 1994).

1 **CITY OF HOMER**
2 **HOMER, ALASKA**

3 City Manager

4 **RESOLUTION 16-006**

5
6 A RESOLUTION OF THE CITY COUNCIL OF HOMER, ALASKA,
7 ADOPTING AN ALTERNATIVE ALLOCATION METHOD FOR THE FY 16
8 SHARED FISHERIES BUSINESS TAX PROGRAM AND CERTIFYING
9 THAT THIS ALLOCATION METHOD FAIRLY REPRESENTS THE
10 DISTRIBUTION OF SIGNIFICANT EFFECTS OF FISHERIES BUSINESS
11 ACTIVITY IN THE COOK INLET FISHERIES MANAGEMENT AREA.
12

13 WHEREAS, AS 29.60.450 requires that for a municipality to participate in the FY 16
14 Shared Fisheries Business Tax Program, the municipality must demonstrate to the
15 Department of Commerce, Community and Economic Development that the municipality
16 suffered significant effects during calendar year 2014 from fisheries business activities; and
17

18 WHEREAS, 3AAC 134.060 provides for the allocation of available program funding to
19 eligible municipalities located within fisheries management areas specified by the
20 Department of Commerce, Community and Economic Development; and
21

22 WHEREAS, 3AAC 134.070 provides for the use, at the discretion of the Department of
23 Commerce, Community and Economic Development, of alternative allocation methods which
24 may be used within fisheries management areas if all eligible municipalities within the area
25 agree to use the method, and the method incorporates some measure of the relative
26 significant effect of fisheries business activity on the respective municipalities in the area; and
27

28 WHEREAS, The Homer City Council proposes to use an alternative allocation method
29 for allocation of FY 16 funding available within the Cook Inlet Fisheries Management Area in
30 agreement with all other municipalities in this area participating in the FY 16 Shared Fisheries
31 Business Tax Program.
32

33 NOW, THEREFORE, BE IT RESOLVED that the City Council of Homer, Alaska, by this
34 Resolution, certifies that the following alternative allocation method fairly represents the
35 distribution of significant effects during 2014 of fisheries business activity in the Cook Inlet
36 Fisheries Management Area:
37

38 50% divided equally and 50% divided on a per capita basis.
39

40 PASSED and ADOPTED by the City Council of Homer, Alaska this 11th day of January,
41 2016.
42

43
44
45
46
47
48
49
50
51
52
53
54
55
56
57
58
59

CITY OF HOMER

MARY E. WYTHE, MAYOR

ATTEST:

JO JOHNSON, MMC, CITY CLERK

Fiscal Note: Previous year's Acct. No. 400-603-4206 and budgeted for previous years.

1 **CITY OF HOMER**
2 **HOMER, ALASKA**

3 City Manager/
4 Port and Harbor Director

5 **RESOLUTION 16-007**

6
7 A RESOLUTION OF THE CITY COUNCIL OF HOMER, ALASKA, IN
8 SUPPORT OF FULL FUNDING FOR THE STATE OF ALASKA HARBOR
9 FACILITY GRANT PROGRAM IN THE FY 2017 STATE CAPITAL BUDGET.
10

11 WHEREAS, The majority of the public boat harbors in Alaska were constructed by the
12 State in the 1960's and 1970's and serve as critical transportation links and the hubs for
13 waterfront commerce and economic development in Alaskan coastal communities; and
14

15 WHEREAS, These harbor facilities are ports of refuge and areas for protection for
16 ocean-going vessels and fishermen throughout the State of Alaska, especially in coastal
17 Alaskan communities; and
18

19 WHEREAS, Over the past 30 years the State of Alaska has transferred ownership of
20 most of these State-owned harbors to local municipalities with many of these harbor facilities
21 in poor condition due to failure to keep up with maintenance; and
22

23 WHEREAS, When local municipal harbormasters formulated their annual harbor
24 facility budgets they inherited a major financial burden that their local municipal
25 governments could not afford; and
26

27 WHEREAS, In response to this financial burden, the Governor and Alaska Legislature
28 passed legislation supported by the Alaska Association of Harbormasters and Port
29 Administrators (AAHPA) to create the Harbor Facility Grant Program, AS 29.60.800; and
30

31 WHEREAS, The AAHPA endorses the Department of Transportation and Public
32 Facilities administrative review process to review, score, and rank applicants to the Harbor
33 Facility Grant Program since State funds may be limited; and
34

35 WHEREAS, For each harbor facility grant application these municipalities have
36 committed to invest 100% of the design and permitting costs and 50% of the construction
37 cost; and
38

39 WHEREAS, The City of Homer recently completed a large harbor float refurbishment
40 project that received 50% of its funding through this program and recognizes that this critical
41 harbor infrastructure maintenance improvement would not have been possible without the
42 State's assistance; and

43 WHEREAS, The City of Homer recognizes the value of investing tax dollars into ports
44 and harbors in Alaska as a good investment that produces far reaching regional benefits to
45 the tax payers; and

46
47 WHEREAS, The State of Alaska Municipal Harbors Grant program vets good solid
48 projects though its application process that achieve these regional benefits and help
49 communities maintain this high value harbor infrastructure in perpetuity; and

50
51 WHEREAS, The municipalities of the City of Aleknagik, the Municipality of Anchorage,
52 the City and Borough of Juneau, the City of Kodiak, the City and Borough of Sitka, the
53 Municipality of Skagway, the City of Valdez, the City and Borough of Wrangell, and the City of
54 Whittier have offered to contribute \$20,648,514 in local match funding for FY2017 towards
55 nine harbor projects of significant importance locally as required in the Harbor Facility Grant
56 Program; and

57
58 WHEREAS, Completion of these harbor facility projects is all dependent on the 50%
59 match from the State of Alaska's Harbor Facility Grant Program; and

60
61 WHEREAS, During the last ten years' the Municipal Harbor Facility Grant Program has
62 only been fully funded twice, creating a backlog of projects necessary to repair and replace
63 these former State-owned harbors in excess of \$100,000,000.

64
65 NOW, THEREFORE, BE IT RESOLVED that the City Council of Homer, Alaska, by this
66 Resolution, urges full funding in the amount of \$20,648,514 by the Governor and the Alaska
67 Legislature for the State of Alaska's Municipal Harbor Facility Grant Program in the FY 2017
68 State Capital Budget in order to ensure enhanced safety and economic prosperity among
69 Alaskan coastal communities.

70
71 PASSED and ADOPTED by the City Council of Homer, Alaska this 11th day of January,
72 2016.

73
74 CITY OF HOMER

75
76 _____
77 MARY E. WYTHE, MAYOR

78
79 ATTEST:
80
81 _____
82 JO JOHNSON, MMC, CITY CLERK

83
84

85 Fiscal Note: N/A

**CITY OF HOMER
HOMER, ALASKA**

Lewis

RESOLUTION 16-008

A RESOLUTION OF THE CITY COUNCIL OF HOMER, ALASKA,
SUPPORTING THE ESTABLISHMENT OF A SYRINGE EXCHANGE
PROGRAM IN HOMER.

WHEREAS, Syringe exchange programs (SEPs) provide free sterile syringes and collect used syringes from injection drug users to reduce transmission of blood borne pathogens, including HIV, and Hepatitis B and C viruses; and

WHEREAS, Most SEPs also offer HIV/Hepatitis counselling and testing and referral to substance abuse treatment; and

WHEREAS, There are over 1,000 new cases of Hepatitis C and over 100 new cases of HIV in Alaska each year; and

WHEREAS, SEPs reduce virus transmission by about 30%; and

WHEREAS, There is significant cost savings associated with reducing instances of Hepatitis C, HIV, and injection drug related bacterial infections; and

WHEREAS, According to the World Health Organization there is compelling evidence that increasing the availability and utilization of sterile injection equipment by injection drug users reduces HIV infection substantially; and

WHEREAS, In 2000 U.S. Surgeon General Dr. Satcher issued a statement that SEPs are an effective HIV prevention strategy and do not encourage the use of illegal drugs; and

WHEREAS, SEPs have the added benefit of increasing recruitment into drug treatment programs and primary care.

NOW, THEREFORE, BE IT RESOLVED by the City Council of Homer, Alaska, that the City of Homer supports the establishment of a Syringe Exchange Program in the City of Homer.

PASSED AND ADOPTED by the Homer City Council this 11th day of January, 2016.

43
44
45
46
47
48
49
50
51
52
53
54

CITY OF HOMER

MARY E. WYTHE, MAYOR

ATTEST:

JO JOHNSON, MMC, CITY CLERK

Fiscal information: N/A

1 **CITY OF HOMER**
2 **HOMER, ALASKA**

3 Reynolds/Cannabis Advisory
4 Commission

5 **RESOLUTION 16-009**

6
7 A RESOLUTION OF THE CITY COUNCIL OF HOMER, ALASKA,
8 REQUESTING THAT ANY ADDITIONAL TAXES LEVIED AGAINST
9 COMMERCIAL MARIJUANA ACTIVITIES BY THE KENAI PENINSULA
10 BOROUGH, ON BUSINESSES LOCATED WITHIN THE MUNICIPAL
11 BOUNDARIES OF HOMER, ALASKA, IS REMITTED TO THE CITY OF
12 HOMER.

13
14 WHEREAS, The State of Alaska is enacting regulations permitting the cultivation,
15 testing, manufacturing, and retail sales of marijuana; and

16
17 WHEREAS, The Kenai Peninsula Borough may find it is in the best interest of the
18 Borough to levy additional taxes on commercial marijuana activities; and

19
20 WHEREAS, The Kenai Peninsula has the systems and regulations in place as a taxing
21 authority; and

22
23 WHEREAS, The City of Homer is proposing to allow for operation of the marijuana
24 industry within municipal boundaries; and

25
26 WHEREAS, The City of Homer does not desire to set up a redundant taxation system;
27 and

28
29 WHEREAS, The City of Homer would like to receive industry taxes without
30 unnecessarily driving up the prices and encouraging the black market to prevail because of
31 the layering of taxes.

32
33 NOW, THEREFORE, BE IT RESOLVED that the Homer City Council hereby expresses its
34 support for the Kenai Peninsula Borough to collect taxes on the marijuana industries and
35 remit those taxes collected within the municipal boundaries of Homer, back to the City of
36 Homer.

38 PASSED AND ADOPTED by the Homer City Council this 11th day of January, 2016.

39

40

CITY OF HOMER

41

42

43

MARY E. WYTHE, MAYOR

44

45 ATTEST:

46

47

48

49 JO JOHNSON, MMC, CITY CLERK

50

51 Fiscal Note: N/A

52



City of Homer

www.cityofhomer-ak.gov

Office of the City Clerk

491 East Pioneer Avenue
Homer, Alaska 99603

clerk@cityofhomer-ak.gov

(p) 907-235-3130

(f) 907-235-3143

Memorandum 16-004

TO: MAYOR WYTHE AND HOMER CITY COUNCIL

FROM: JO JOHNSON, CITY CLERK

DATE: JANUARY 4, 2016

SUBJECT: TRAVEL AUTHORIZATION FOR MAYOR WYTHE AND COUNCILMEMBERS LEWIS AND REYNOLDS TO TRAVEL TO JUNEAU TO ADVOCATE FOR THE CITY FEBRUARY 2 – 4, 2016.

Mayor Wythe and Councilmembers Lewis and Reynolds would like to travel to Juneau February 2 – 4, 2016 to meet with legislators and advocate for the City.

Cost estimates for travel include round trip airfare from Homer to Juneau at \$625.00 and room rates at \$150.00 per night. Per diem is \$58.00 per day, for three meals.

For FY 2016 Council budgeted \$4,500 for transportation and \$2,500 for subsistence. To date \$0 has been expended from Transportation Acct. No. 100.0100.5236, leaving a balance of \$4,500; and \$0 has been expended from Subsistence Acct. No. 100.0100.5237, with a balance of \$2,500 remaining.

RECOMMENDATION:

Discuss the travel and if approved allocate funds for transportation, lodging, and meals.

Fiscal Note: Mayor and Council 2016 Budget: 100.0100.5236 - Transportation: \$4,500.00 and 100.0100.5237 - Subsistence: \$2,500.00.



City of Homer

www.cityofhomer-ak.gov

Office of the City Clerk

491 East Pioneer Avenue
Homer, Alaska 99603

clerk@cityofhomer-ak.gov

(p) 907-235-3130

(f) 907-235-3143

Memorandum 16-005

TO: MAYOR WYTHER AND HOMER CITY COUNCIL

FROM: JO JOHNSON, CITY CLERK

DATE: JANUARY 5, 2016

SUBJECT: TRAVEL AUTHORIZATION FOR COUNCILMEMBER ZAK TO TRAVEL TO ANCHORAGE TO ATTEND THE ALASKA HOUSING SUMMIT JANUARY 6, 2016.

The City of Homer was invited to attend the Alaska Housing Summit in Anchorage on January 6, 2016. The one-day summit hosted by Governor Bill Walker and Lt. Governor Byron Mallott brings together Alaskans from across the state to identify the barriers and seek budget-neutral solutions to the numerous housing challenges facing Alaskans. From homelessness to home financing in rural areas, the problems are pretty well defined, but solutions can come from experts all across the state. Leaders from this sector are invited to participate in break-out sessions throughout the day and will come together in the afternoon to share progress.

Councilmember Zak has agreed to travel on behalf of the City. Due to the late invitation and council meeting schedule it is necessary to request travel authorization after the fact.

Cost estimates for the one day of travel include round trip airfare from Homer to Anchorage at \$250.00 and reimbursement for meals.

For FY 2016 Council budgeted \$4,500 for transportation and \$2,500 for subsistence. To date \$0 has been expended from Transportation Acct. No. 100.0100.5236, leaving a balance of \$4,500; and \$0 has been expended from Subsistence Acct. No. 100.0100.5237, with a balance of \$2,500 remaining.

RECOMMENDATION:

Discuss the travel and if approved allocate funds for transportation and meals.

Fiscal Note: Mayor and Council 2016 Budget: 100.0100.5236 - Transportation: \$4,500.00 and 100.0100.5237 - Subsistence: \$2,500.00.



City of Homer

www.cityofhomer-ak.gov

Office of the City Clerk

491 East Pioneer Avenue
Homer, Alaska 99603

clerk@cityofhomer-ak.gov

(p) 907-235-3130

(f) 907-235-3143

Memorandum 16-006

TO: MAYOR WYTHE AND HOMER CITY COUNCIL

FROM: JO JOHNSON, CITY CLERK

DATE: JANUARY 5, 2016

SUBJECT: AMENDMENT OF RESOLUTION 15-105 FOR MARCH 2016 MEETING SCHEDULE FOR COUNCIL.

Resolution 15-105, setting the 2016 Meeting Schedule was adopted by the Council on December 7, 2015. The March date for the second council meeting was scheduled on the Seward's Day holiday in error.

The second council meeting in March should be Tuesday, March 29, 2016.

RECOMMENDATION:

Approve the correction to the 2016 Meeting Schedule to change the second council meeting in March to Tuesday, March 29, 2016.

1 **CITY OF HOMER**
2 **HOMER, ALASKA**

3 City Clerk

4 **RESOLUTION 15-105**
5

6 A RESOLUTION OF THE CITY COUNCIL OF HOMER, ALASKA,
7 ESTABLISHING THE 2016 REGULAR MEETING SCHEDULE FOR
8 THE CITY COUNCIL, ECONOMIC DEVELOPMENT ADVISORY
9 COMMISSION, LIBRARY ADVISORY BOARD, PARKS AND
10 RECREATION ADVISORY COMMISSION, ADVISORY PLANNING
11 COMMISSION, PORT AND HARBOR ADVISORY COMMISSION,
12 CANNABIS ADVISORY COMMISSION, PERMANENT FUND
13 COMMITTEE, AND PUBLIC ARTS COMMITTEE.
14

15 WHEREAS, Pursuant to Homer City Code Section 1.14.020, the City Council annually
16 sets the schedule for regular and some special meetings, noting the dates, times and places
17 of the City Council, Advisory Commissions, the Library Advisory Board, and standing
18 committee meetings; and
19

20 WHEREAS, The public is informed of such meetings through notices located at the City
21 Clerk's Office, Clerk's Calendar on KBBI, the City Clerk's Website, and postings at the Public
22 Library; and
23

24 WHEREAS, HCC 1.14.020 - 040 states that meetings may be advertised in a local paper
25 of general circulation at least three days before the date of the meeting and that special
26 meetings should be advertised in the same manner or may be broadcast by local radio at
27 least twice a day for three consecutive days or two consecutive days before the day of the
28 meeting plus the day of the meeting; and
29

30 WHEREAS, HCC 1.14.010 notes that the notice of meetings applies to the City Council
31 and all commissions, boards, committees, subcommittees, task forces and any sub-unit of
32 the foregoing public bodies of the City, whether meeting in a formal or informal meeting; that
33 the failure to give the notice provided for under this chapter does not invalidate or otherwise
34 affect any action or decision of a public body of the City; however, this sentence does not
35 change the consequences of failing to give the minimum notice required under State Statute;
36 that notice will ordinarily be given by the City Clerk; and that the presiding officer or the
37 person or persons calling a meeting are responsible for notifying the City Clerk of meetings in
38 sufficient time for the Clerk to publish notice in a newspaper of general circulation in the City;
39 and
40

41 WHEREAS, This Resolution does not preclude additional meetings such as emergency
42 meetings, special meetings, worksessions, and the like; and

43 WHEREAS, Council adopted Resolution 06-144 on October 9, 2006 establishing the
 44 Regular Meeting site for all bodies to be the City Hall Cowles Council Chambers.
 45

46 NOW, THEREFORE, BE IT RESOLVED by the Homer City Council, that the 2016 meeting
 47 schedule is established for the City Council, Economic Development Advisory Commission,
 48 Library Advisory Board, Parks and Recreation Advisory Commission, Advisory Planning
 49 Commission, Port and Harbor Advisory Commission, Permanent Fund Committee, and Public
 50 Arts Committee of the City of Homer, Alaska, as follows:
 51

52 Holidays - City Offices closed:

January 1*, New Year's Day, Friday	February 15*, Presidents' Day, the third Monday	March 28*, Seward's Day, last Monday	May 30*, Memorial Day, last Monday	July 4*, Independence Day, Monday	September 5*, Labor Day, first Monday
October 18*, Alaska Day, Tuesday	November 11*, Veterans Day, Friday	November 24* Thanksgiving Day, Thursday	November 25*, Friday, the day after Thanksgiving	December 26**, Christmas, Monday	

53
 54 *Indicates holidays - City offices closed.

55 **If on a Sunday, the following Monday is observed as the legal holiday; if on a Saturday, the
 56 preceding Friday is observed as the legal holiday pursuant to the City of Homer Personnel
 57 Rules and Regulations.

58
 59 CITY COUNCIL (CC)

January 11, 25	February 8, 22	March 14, 28	April 11, 25	May 9, 23	June 13, 27
July 11**, 25	August 8, 22	September 12, 26	October 4 Election	October 10, 24, for Oath of Office 17*	Canvass Board October 7 or 10
November 1 Runoff Election	November 14**, 28	December 12****	December 19**** if needed		

60
 61 City Council's Regular Committee of the Whole Meetings at 5:00 p.m. to no later than 5:50
 62 p.m. prior to every Regular Meeting which are held the second and fourth Monday of each
 63 month at 6:00 p.m. ***The City Council traditionally reschedules regular meetings that fall on
 64 holidays or High School Graduation days, for the following Tuesday. Council will not conduct
 65 a First Regular Meeting in July.

66 AML Annual Conference Week is tentatively scheduled for November 14 – 18, 2016.

67 *Tuesday meeting due to Memorial Day/Alaska Day.

68 **There will be no First Regular Meeting in July or November.

69 **** The City Council traditionally cancels the last regular meeting in December and holds the
 70 first regular meeting and one to two Special Meetings as needed. Generally the second
 71 Special Meeting the third week of December, will not be held.

72

73 ECONOMIC DEVELOPMENT ADVISORY COMMISSION (EDC)

January 12	February 9	March 8	April 12	May 10	June 14
July 12	August 9	September 13	October 11	November 8	December 13

74

75 Economic Development Advisory Commission Regular Meetings are held on the second
 76 Tuesday of each Month at 6:00 p.m.

77

78 LIBRARY ADVISORY BOARD (LAB)

February 2	March 1	April 5	May 3	August 2
		October 4	November 1	December 6

79

80 Library Advisory Board Regular Meetings are held on the first Tuesday of the months of
 81 February, March, April, May, August, October, November, and December at 5:30 p.m.

82

83 PARKS AND RECREATION ADVISORY COMMISSION (P/R)

January 21*	February 18	March 17	April 21
May 19	June 16		August 18
September 15	October 20	November 17	

84

85 Parks and Recreation Advisory Commission Regular Meetings are held on the third Thursday
 86 of each month at 5:30 p.m. with the exception of January, July, and December. *January
 87 meeting added by the Commission.

88

89 PLANNING COMMISSION (P/C)

January 6, 20	February 3, 17	March 2, 16	April 6, 20	May 4, 18	June 1, 15
July 20**	August 3, 17	September 7, 21	October 5, 19	November 2**	December 7**

90

91 Advisory Planning Commission Regular Meetings are held on the first and third Wednesday of
 92 each month at 6:30 p.m. **There will be no First Regular Meeting in July or Second Regular
 93 Meetings in November and December.

94

95

96 PORT AND HARBOR ADVISORY COMMISSION (P/H)

January 27	February 24	March 23	April 27	May 25	June 22
July 27	August 24	September 28	October 26		December 7

97
98 Port and Harbor Advisory Commission Regular Meetings are held on the fourth Wednesday of
99 each month at 5:00 p.m., with the exception of May, June, July and August meetings that are
100 held at 6:00 p.m. The Regular Meeting for November is cancelled and the December meeting
101 is scheduled for the first Wednesday of the month.

102

103 CANNABIS ADVISORY COMMISSION (CAC)

January 28	February 25	March 24	April 28	May 26	June 23
July 28	August 25	September 22	October 27	November 29	December 15

104

105 Cannabis Advisory Commission Regular Meetings are held on the fourth Thursday of each
106 month at 5:30 p.m. The Regular Meeting in the month of November is scheduled for the last
107 Tuesday of the month and the Regular Meeting in December is scheduled for the third
108 Thursday of the month.

109

110 PERMANENT FUND COMMITTEE (PFC)

February 11	May 12	August 11	November 10
-------------	--------	-----------	-------------

111

112 Permanent Fund Committee Regular Meetings are held quarterly on the second Thursday of
113 the months of February, May, August, and November at 5:15 p.m.

114

115 PUBLIC ARTS COMMITTEE (PAC)

February 11	May 12	August 11	November 10
-------------	--------	-----------	-------------

116

117 Public Arts Committee Regular Meetings are held quarterly on the second Thursday of the
118 months of February, May, August, and November at 5:00 p.m.

119

120 PASSED AND ADOPTED by the Homer City Council this 7th day of December, 2015.

121

122

CITY OF HOMER

123

124

125

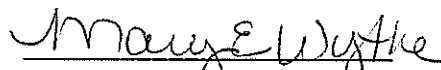

MARY E. WYTHE, MAYOR

126

127

128

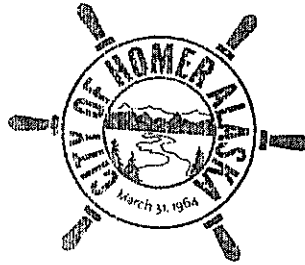
129



130 ATTEST:

131
132 
133 _____
134 JO JOHNSON, MMC, CITY CLERK

135
136 Fiscal Impact: Advertng of meetings in regular weekly meeting ad and advertising of any
137 additional meetings.

VISITORS

Alaska Salmon Alliance Presentation to the City Council of Homer on “The Economic Impact of the Seafood Industry in Southcentral Alaska”, prepared by the McDowell Group for the Alaska Salmon Alliance, June 2015

Arni Thomson, Executive Director
January 11, 2015

The Seafood Industry is a Significant Economic Driver in Southcentral Alaska.

Southcentral Alaska Overview: The Alaska Salmon Alliance (ASA) is a professional trade organization comprised of regional seafood processors, namely Snug Harbor Seafoods, Pacific Star, Great Pacific, Icicle Seafoods, Inlet Fish Producers, Fishhawk and commercial fishermen. Our mission is to promote science-based salmon management and policies in order to preserve long-term opportunities for all salmon user groups in Cook Inlet. The ASA also promotes collaboration amongst all user groups to find solutions that will enable sustainable salmon harvests that all can share. The ASA main office is located in Kenai at 110 N. Willow Street and ASA Board members and myself have held regular monthly Board meetings at the Kenai office since January 2013. I maintain an office in Anchorage to coordinate outreach, communication and public education about the sustainability and economic impact of the SC Alaska commercial fishing industry in Anchorage, Eagle River and the Mat-Su Valley.

Our organization selected the McDowell Group for this project specifically due to the firm’s expertise within the seafood industry, as well as their recent experience evaluating economic impacts of several other key Alaska sectors including oil, gas, visitor, and mining industries.

Southcentral is a well-known hub for oil, gas, and tourism. The region also plays a critical role in maximizing the value of commercial fishery resources. This report clearly documents the importance of the seafood industry in Southcentral Alaska’s regional and local economies.

The seafood industry accounted for 8,130 “full-time equivalent jobs” (FTEs) and over \$400 million in labor income in Southcentral Alaska during 2013, including multiplier effects. The study also explains the critical role seafood plays in Cordova, Kenai, Homer, Seward, and Valdez, and provides new information on the significance of the industry in Anchorage and the Mat-Su Valley. Nearly 11,000 Southcentral residents were directly employed in the industry at some point during 2013, and are supported by the work of several thousand additional Alaskans in the region.

In 2013, the SC AK seafood industry created \$1.2 billion of economic output. The first wholesale value of all seafood produced by Southcentral processors was \$685 million (the basis for direct economic output, which includes ex-vessel value earned by fishermen and the value added by processors). Secondary impacts to finance, transportation and logistics, fuel and equipment, added an estimated \$501 million.

Enumeration of the FTE jobs stimulated through secondary impacts, and the secondary labor income are at the core of what is new in the McDowell Report. A regional overview and six community profiles provide lists of the secondary businesses and descriptions of how they interact with the fishing and seafood industry.

Community Impact Profile: Homer

Homer is a major gateway and destination port for the Kenai Peninsula. Fishing, both commercial and sport is the foundation of Homer's economy, which is primarily driven by the seafood and visitor industries. Homer ranks as the #2 port in SC Alaska in resident seafood industry employment. Homer also has the distinction of being the #2 community in the state for resident fishermen earnings at \$83 million. (Pages 9 and 11).

Commercial fishing directly employed 1,280 workers in seasonal and full-time equivalent jobs, of which 1,230 were local Homer residents. This converts to 980 FTEs and when secondary impact jobs are added in, there is a total of 1,670 FTE jobs. Fishing related jobs are occupied by 34 percent of all working age residents. Total direct estimated labor income is \$48 million and when indirect and induced jobs are added in, it is \$83 million. There are 455 active permit holders in Homer and each represents a locally-based small business. These businesses had an estimated asset value of \$180 million in 2013, or about \$395,000 per active permit holder (pages 45 and 47).

Homer's resident fishing fleet is a diversified group with many participating in multiple fisheries. Most of their earnings come from landing fish in other communities. While Homer is the first or second-largest port in the state for halibut landings, worth ex vessel \$24.4 million in 2013, halibut landed by Homer resident fishermen comprised only 15 percent of their gross earnings.

Homer fishermen are very active in Southcentral driftnet and seine fisheries. Overall, Southcentral fisheries accounted for 60 percent of local resident gross earnings in 2013. Homer fishermen are also active in southwestern Alaska fisheries. Fisheries outside of Southcentral provided 40 percent of local resident gross earning in 2013. Whether the income comes from regional or other Alaska fisheries, this activity provides significant benefits for the local and regional economies.

Five seafood processing companies operate processing plants and buying stations in Homer. Homer's primary processors employed an estimated 170 workers in 2013, generating an estimated \$1.8 million in labor income, and accounting for 35 FTE jobs. In addition, 45 fishermen are licensed as direct-to-market companies. The estimated asset value of the seafood processors (based on assessed value, not market value) is \$4.9 million. Homer-based processors and buying stations, receive product landed there and truck fish on ice to plants in Kenai, Seward and even Anchorage, thus the seafood buyers and the port are providing an important service for the Peninsula.

Combining the number of workers in Homer, the Kenai region and Seward, there is a total of 4,160 workers employed in the seafood industry on the Kenai Peninsula, 38 percent of the 10,840 total seafood workers in Southcentral Alaska (p. 2).

Homer and the seafood industry benefit from the city's well-developed harbor facilities and marine support sector. Homer's harbor features 920 reserved moorage slips, 6,000 linear feet of transient moorage space, two large docks, a fish dock equipped with eight cranes, and two tidal grid boat haulouts. In addition, an ice plant, gear storage yard, and cold storage facility are located adjacent to Homer's boat harbor. Fishermen and other boat owners also utilize two private boat yards (the Northern Enterprises Boat Yard and the Homer Boat Yard). Resident Homer commercial fishing vessels occupy 332 slips, other Southcentral residents occupy an additional 106 slips for a total of 438 slips in the harbor occupied by Southcentral Alaska residents. There are also a large number of local and SC AK resident boats stored in the two private boat yards that utilize local service companies for annual maintenance and repair.

Homer is the largest Southcentral port for commercial fishing vessel repair, building, and maintenance. The community under the umbrella of the unique Homer Marine Trades Association, offers a broad range of companies and infrastructure capable of servicing commercial fishing vessels. The marine support sector provides a wide range of products and services, not only for fishing vessels based in Homer, but it also attracts small to mid-sized commercial boats from around the state. The community has five boat builders, over a dozen repair and maintenance specialist companies, a seine net manufacturer, a marine apparel manufacturer, multiple marine insurance agencies, and a major permit/boat broker. The seafood industry creates approximately 225 FTE-jobs in Homer's marine support sector and 125 other indirect FTE jobs. In addition, Homer's marine support sector also benefits from the large number of pleasure, sport fishing, and sightseeing boats based in Homer. A list of 59 seafood industry support businesses in Homer is provided on pages 53-54. A number of these businesses also provide services for the marine-based visitor industry.

The head of a Homer fishing family quoted in the report has this to say about the importance of small business fishing enterprises in Homer: "The impact of the family's fishing business is significant. Just one boat pays out over \$500,000 a year in crew shares; then add \$500,000 in boat expenses for fuel, bait, maintenance and repairs, supplies, insurance, equipment, etc.... One fisherman's expense is another member of the community's income." "I feel like many times commercial fishermen are taken for granted in Homer, but there is still a great deal of potential for Homer's fishing industry and marine trades businesses to grow."

The McDowell Report and a summary of it are found on the ASA website at www.aksalmonalliance.org.

The Economic Impact of the Seafood Industry in Southcentral Alaska

The commercial seafood industry generates substantial economic benefits in Southcentral Alaska. The industry **directly employed 10,840 people** in Southcentral Alaska, including 7,660 regional residents, in 2013. Including multiplier effects, the seafood industry created an estimated 8,130 full-time equivalent (FTE) jobs and **\$411 million in annual labor income**. The majority of this economic activity is related to regional commercial fisheries; however, Southcentral also contains many resident fishermen who bring home earnings from other Alaska fisheries and the region benefits indirectly from fisheries in western Alaska.

- ▶ **JOBS: 8,130** full-time equivalent jobs created in Southcentral during 2013
- ▶ **INCOME: \$411 million** in regional labor income
- ▶ **GROWTH: 126 percent** growth in residents' gross fishing earnings since 2004
- ▶ **BACKHAUL: \$70/year** in savings for Southcentral households per year

Prepared by



Prepared for



Southcentral Alaska



Key Findings

- ▶ The seafood industry directly employed 10,840 people in Southcentral Alaska, including 7,660 regional residents, in 2013. Including direct and multiplier effects, the seafood industry created an estimated 8,130 full-time equivalent jobs and \$411 million in labor income.
- ▶ A total of 5,729 commercial fishermen live in Southcentral Alaska and participate in fisheries throughout the state. Each of the region's 2,168 active resident permit holders represents a small business yielding similar economic impacts as other independent, locally-owned businesses.
- ▶ The Southcentral seafood processing sector employed an estimated 4,590 workers in 2013 and paid out \$61 million in wages. The workforce included 1,410 resident workers who earned \$20.3 million. The region contains 35 processing plants.
- ▶ Processing operations are expanding in Valdez and Cordova to further capitalize on Prince William Sound salmon resources.
- ▶ The marine service sector in Homer and Seward continues to add capacity and new capabilities. Overall, the seafood industry indirectly created 1,390 FTE jobs and \$69 million in labor income in 2013, including hundreds of marine service jobs.
- ▶ Southcentral is home to three non-profit salmon hatchery associations, as well as state and federal fishery management agencies. These organizations employed approximately 520 workers and created 300 FTE jobs in 2013.
- ▶ Commercial seafood generated \$1.2 billion in total economic output in Southcentral Alaska in 2013. This includes \$685 million in first wholesale value of seafood products and \$501 million in value added through secondary impacts.



See the full report for more information, available at www.aksalmonalliance.org/



- ▶ Nearly a third (32 percent) of all Alaska resident commercial fishermen live in Southcentral. Its 2,168 active permit holders grossed \$308 million in 2013, accounting for 38 percent of all Alaska resident commercial fishing income.
- ▶ A total of 20 Southcentral communities had collective gross fishing earnings exceeding \$1 million in 2013.

- ▶ Economies in Cordova, Homer, and the Kenai region each received more than \$50 million in labor income as a result of the seafood industry in 2013; Anchorage/Mat-Su received \$149 million. The majority of these income figures is earned by residents, indirectly benefitting the regional economy.
- ▶ Commercial fisheries create hundreds of millions of pounds of backhaul for regional cargo carriers. It is conservatively estimated that seafood backhaul saves Southcentral households at least \$70 per year in shipping costs by offsetting northbound freight rates.
- ▶ Salmon is the foundation of the region's seafood industry, accounting for 85 percent of total first wholesale value of seafood produced in Southcentral. Sockeye and pink salmon are the most important species in the region.
- ▶ Large processing companies rely on nonresident workers to fill many seasonal positions, but the best processing jobs tend to be held by local, year-round residents.
- ▶ The seafood industry is Alaska's largest private sector employer and most valuable sustainable resource. Southcentral residents and communities are a critical part of it past, present, and future.



2013 SNAP SHOT Seafood Industry

Seafood Industry Workers	10,840
Industry Dependent FTE Jobs	8,130
Total Area Employment	279,500
Total Area Population	463,400
Industry Dependent Labor Income	\$411 M
Gross Earnings of Resident Fishermen	\$308 M
Value of Local Seafood Assets	\$766 M
Resident Commercial Fishermen	5,724
Local Processing Facilities	35

Photo Credits: (Clockwise from upper left) Arni Thompson, Copper River Seafoods, and the Sturman Family.



It is estimated that Alaska’s seafood industry supported approximately 2,900 FTE jobs and \$149 million in labor income in the Anchorage/Mat-Su economy during 2013 (including multiplier effects). Because the area is a critical hub for fisheries in Southcentral and western Alaska, and home to more than 2,200 commercial fishermen, Anchorage/Mat-Su has more seafood-related jobs than any other Southcentral community. The area benefits from most of the state’s commercial fisheries, due to related business and household spending from other regions which eventually flows through Anchorage.

Economic Impact of the Seafood Industry in Anchorage/Mat-Su, 2013

	FTE Jobs	Labor Income (millions)
Resident Commercial Fishing	1,050	\$52.0
Seafood Processing	340	\$16.8
Gov. Related & Hatcheries	150	\$14.1
Direct Industry Total	1,540	\$82.9
Indirect (Business Spending)	450	\$22.0
Induced (Household Spending)	890	\$43.9
Total Economic Impacts	2,880	\$148.8

Notes: Figures may not sum due to rounding. Commercial fishing labor income figures include estimated income from tender vessels owned by local residents. Source: McDowell Group estimates based on ADF&G, DCCED, DOLWD, IMPLAN, NMFS, and industry interviews.



2013 SNAP SHOT Seafood Industry

Seafood Industry Workers	3,440
Industry Dependent FTE Jobs	2,880
Total Area Employment	239,600
Total Area Population	396,800
Industry Dependent Labor Income	\$148.8 M
Gross Earnings of Resident Fishermen	\$107.5 M
Value of Local Seafood Assets	\$228.0 M
Local Resident Skippers	724
Local Processing Facilities	7

The seafood industry directly employs 3,440 workers who reside in Anchorage/Mat-Su year-round or seasonally. Resident commercial fishermen and local processors hold operating assets worth an estimated \$228 million, primarily comprised of fishing permits, vessels, and IFQ’s.

For context, seafood generates more FTE jobs for local residents than mining (not including oil and gas) and creates a similar number of local jobs as the University of Alaska system. In addition, seafood provides a boost to the local restaurant and hotel sector.

A Growing Hub

The Anchorage/Mat-Su area plays a large and growing role in Alaska's seafood industry. Consider the following:

Shipping. Anchorage port facilities shipped out 168 million pounds of frozen seafood in 2013, in addition millions of pounds of fresh seafood is flown out of the Ted Stevens Anchorage International Airport each year.

Management. Many commercial fishery management and research activities are coordinated from Anchorage. The city will likely play a key role in expanding Arctic fisheries.

CDQ Groups. All six CDQ groups have executive and managerial offices in Anchorage or Mat-Su. These groups hold nearly \$1 billion in combined net assets will likely play an increasing role in Alaska's seafood industry.

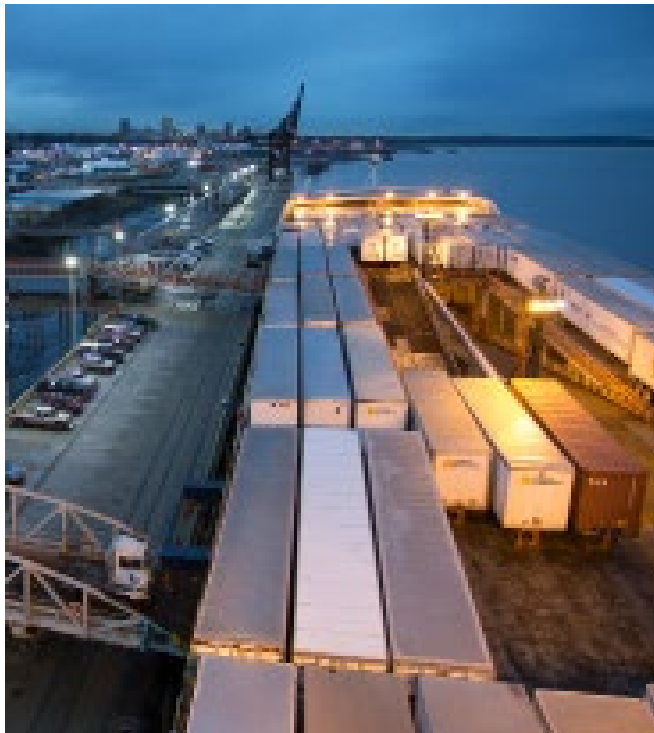

Photo Credit: Totem Ocean.

Local Seafood Business Profiles

Great Pacific Seafoods

Great Pacific Seafoods began processing Alaska seafood in 1989, signing a lease on their Whittier facility the day before the Exxon Valdez oil spill. The company overcame the spill to become one of the largest fresh salmon processors in the state. Great Pacific typically employs a peak workforce of 300 workers, spread evenly between three Southcentral production facilities in Anchorage, Whittier, and Kenai. In addition, Great Pacific has buying operations in Kotzebue and Homer.



Great Pacific creates secondary economic benefits for airlines, trucking companies, packaging companies, and fuel distributors. "We fly in a couple million pounds of salmon from Kotzebue on Northern Air Cargo. All that product gets processed in our Anchorage plant before being loaded up on planes or trucks to be shipped out to buyers, mostly in the lower 48. We transport a lot of product via truck within Southcentral as well," explains General Manager Roger Stiles.

Copper River Seafoods

Copper River Seafoods is an Alaska-based processing and marketing company with production facilities in Anchorage, Kenai, Cordova, Naknek, Togiak, and Kotzebue. The company employs approximately 180 workers in year-round positions at its Anchorage plant and offices. A variety of workforce development classes are also held at its Anchorage facilities.



Copper River Seafoods relies heavily on nearly every major transportation entity operating in the Anchorage and Mat-Su area, including the Alaska Marine Highway System, Lynden, FedEx, UPS, and Alaska Airlines. In addition, nearly all of the company's operational supplies, such as provisions, bunk house supplies, building materials, and office supplies are purchased in Anchorage and delivered to the primary processing facilities via the Alaska Marine Highway System or air cargo carriers. The company provides local residents with a wide variety of Alaska seafood products via local retailers such as 3 Bears, Costco, Sam's Club, Walmart, and numerous local restaurants.

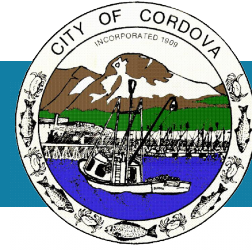

The seafood industry supported an estimated 1,470 FTE-jobs in Cordova and generated \$73 million in labor income during 2013 (including multiplier effects). Approximately 58 percent of all working age residents were directly employed in the commercial seafood industry at some point during 2013. Cordova ranked 14th among U.S. ports in terms of both ex-vessel value and harvest volume, on average, between 2010 and 2013.

“Virtually every business in Cordova is dependent on the seafood industry,” says Cordova mayor Jim Kacsh.

Economic Impact of the Seafood Industry in Cordova, 2013

	FTE Jobs	Labor Income (millions)
Resident Commercial Fishing	630	\$31.0
Seafood Processing	310	\$15.1
Hatchery & Mgmt.	80	\$3.8
Direct Industry Total	930	\$46.1
Indirect (Business Spending)	250	\$12.4
Induced (Household Spending)	290	\$14.3
Total Economic Impacts	1,470	\$72.8

*Notes: Figures may not sum due to rounding. Commercial fishing labor income figures include estimated income from tender vessels owned by local residents.
Source: McDowell Group estimates based on ADF&G, DCCED, DOLWD, IMPLAN, NMFS, and industry interviews.*



2013 SNAP SHOT Seafood Industry

Seafood Industry Workers	1,810
Industry Dependent FTE Jobs	1,470
Total Area Population	2,300
Value of 2013 Local Landings	\$91.5 M
Industry Dependent Labor Income	\$72.8 M
Gross Earnings of Resident Fishermen	\$56.8 M
Value of Local Seafood Assets	\$156.6 M
Local Commercial Fishing Fleet (Number of Vessels Homeported)	603
Local Processing Facilities	6

The seafood industry directly employed 1,810 workers who reside in Cordova either year-round or seasonally (including approximately 840 year-round residents). Resident commercial fishermen and local processors hold operating assets worth an estimated \$157 million, the largest per-capita seafood industry asset value of any Southcentral community by a wide margin.

Cordova features five primary processing companies, six production facilities, and a fleet of 603 fishing and tender vessels. Alaska fishermen landed nearly \$92 million worth of seafood in Cordova during 2013 (in ex-vessel terms), ranking 7th in the U.S.

Pink & Red Salmon Foundation

Cordova is synonymous with Copper River salmon. The community is heavily dependent on wild and hatchery-enhanced sockeye and pink salmon runs; these species account for 76 percent of Cordova's landings by value.

PWSAC, a local hatchery association, is a major economic driver in the region. Its hatcheries provide the vast majority of the area's pink salmon and a substantial percentage of Copper River sockeye. The hatchery association has been allowed to expand pink production under its existing permits with ADF&G, which should result in even more resources available to the industry. Local processors continue to invest in Cordova, adding production capacity, housing, and value-added product lines.

Local Fisherman Profile

Ken Jones, F/V Serenity

Ken Jones, a 23-year old Cordova fisherman, exemplifies the potential available to Alaskans in the seafood industry. Jones used a mix of hard work, experience, resourcefulness, and a little good luck to fast track his fishing career.

Jones started seining on his dad's boat at eight-years old. Later in high school he purchased a PWS seine permit and a boat. After finding a spare seine net under a tarp in a friend's yard, he spent \$2,000 on a seine skiff and started fishing for himself. Today he owns two fishing vessels, including a newly constructed 50-foot seiner and a gillnetter that keep him busy from May through October.

Living year-round in Cordova, Ken spends significant amounts of money in the community. "Depending on the year, I spend \$200,000 to \$500,000 annually in the community. This includes fuel, groceries, crew shares, parts, and other expenses. I hire mechanics, welders, net-builders, electricians, and other local businesses to keep my boats in shape," says Jones.



Cordova gillnetters charge out to sea for a fishing opener.



Fishing, both commercial and sport, is the foundation of Homer's economy, which is primarily driven by the seafood and visitor industries. It is estimated that Alaska's commercial seafood industry directly employed 1,280 workers and supported a total of 1,670 FTE-jobs in Homer during 2013 (including direct and secondary effects). The majority of Homer's seafood jobs are held by local residents. The industry generated an estimated \$83 million in labor income during 2013 and ranked second among all Alaska communities (after Kodiak) in terms of total gross fishing earnings by local residents.

Economic Impact of the Seafood Industry in Homer, 2013

	FTE Jobs	Labor Income (millions)
Resident Commercial Fishing	920	\$45.4
Seafood Processing	35	\$1.8
Fishery Mgmt. & Other	20	\$1.2
Direct Industry Total	980	\$48.4
Indirect (Business Spending)	350	\$17.2
Induced (Household Spending)	350	\$17.2
Total Economic Impacts	1,670	\$82.8

*Notes: Figures may not sum due to rounding. Commercial fishing labor income figures include estimated income from tender vessels owned by local residents.
Source: McDowell Group estimates based on ADF&G, DCCED, DOLWD, IMPLAN, NMFS, and industry interviews.*



2013 SNAP SHOT Seafood Industry

Seafood Industry Workers	1,280
Industry Dependent FTE Jobs	1,670
Total Area Population	5,100
Value of 2013 Local Landings	\$25.6 M
Industry Dependent Labor Income	\$83.1 M
Gross Earnings of Resident Fishermen	\$56.8 M
Value of Local Seafood Assets	\$184.7 M
Local Commercial Fishing Fleet (Number of Vessels Homeported)	487
Local Processing Facilities or Buying Stations	5

Homer is known as the halibut fishing capital of the world. However, the community also benefits greatly from other fisheries around the state, as IFQ halibut and black cod fisheries only accounted for 15 percent of total gross earnings by resident commercial fishermen in 2013.

Nearly 500 commercial fishing vessels homeport in the community and local seafood assets totaled \$185 million in 2013. Nearly all seafood assets are held by local resident fishermen. Homer contains four relatively small processing companies and one buying station, underscoring the fleet's reliance on other fisheries and regional ports.

Tailor-made Marine Services



*Nothern Enterprises Boatyard in Homer
Photo Credit: Homer Tribune.*

Homer features a robust marine support sector including: two boat yards, five boat builders, over a dozen marine repair/maintenance companies, net and marine apparel manufacturers, multiple marine insurance agencies, and a major permit/boat broker. The seafood industry creates approximately 225 FTE jobs in Homer's marine support sector and 125 other indirect jobs in Homer.

Commercial fishing boats built in Homer are tailored to meet the unique demands of Alaska fisheries. After a boat is built, the fishing vessel can be completely outfitted in Homer without making an expensive run to Puget Sound.

The Homer Marine Trades Association also provides courses in marine trades to local high school and college students. "There's always going to be a need for skilled tradespeople and that's an aspect many of our members are struggling with. It's hard to find good talent," says Matt Alward, vice president of the Association.

Local Fishing Family Profile

The Laukitis Family

The Laukitis family lives in Homer and participates in fisheries from Bristol Bay, to the Bering Sea and Gulf of Alaska. The family runs two boats; one boat works seasonally with family members aboard and the other fishes year round in various areas around the state.

The family fishing business got its start setnetting in False Pass 25 years ago. The Laukitis's have wintered in Homer for about 15 years, but travel to where the fish are during the summer. The family is very engaged in the local community and the Alaska seafood industry. In addition to coaching hockey during the winter and local volunteer work, members of the Laukitis family are involved in numerous seafood industry associations/councils at the regional and statewide level.

The Laukitis family usually has at least one boat in Homer in the winter for maintenance and shipyard work. "Just one boat pays out over \$500,000 a year in crew shares; then add \$500,000 in boat expenses for fuel, bait, maintenance and repairs, supplies, insurance, equipment, etc. One fisherman's expenses is another member of the community's income," says Buck Laukitis. "Homer is a major small boat port with potential for more marine support work. I feel like many times commercial fishermen are taken for granted in Homer, but there is still a great deal of potential for Homer's fishing industry and marine trades businesses to grow."



*Teal and Claire (Laukitis) picking salmon
Photo Credit: Scott Dickerson Photography.*

Kenai Area



The seafood and visitor industries are major economic drivers in Kenai. Both sectors rely heavily on Cook Inlet salmon resources.

It is estimated that Alaska's commercial seafood industry directly employed 2,230 workers, supporting a total of 1,030 FTE jobs and \$51 million of labor income in the Kenai area during 2013 (including multiplier effects). The industry directly employs approximately 1,630 local area residents, or about 7 percent of all working age Kenai area residents. More commercial fishermen live in the Kenai area than Cordova, Valdez, and Seward combined.



2013 SNAP SHOT Seafood Industry

Seafood Industry Workers	2,230
Industry Dependent FTE Jobs	1,030
Total Area Population	37,400
Value of 2013 Local Landings	\$40.1 M
Industry Dependent Labor Income	\$51.0 M
Gross Earnings of Resident Fishermen	\$29.3 M
Value of Local Seafood Assets	\$90.4 M
Fishermen Fishing Permits in Cook Inlet Salmon Fisheries	946
Local Processing Facilities	10

Economic Impact of the Seafood Industry in the Kenai Region, 2013

	FTE Jobs	Labor Income (millions)
Resident Commercial Fishing	335	\$16.5
Seafood Processing	210	\$10.3
Mgmt. & Hatchery	55	\$2.9
Direct Industry Total	600	\$29.7
Indirect (Business Spending)	180	\$8.9
Induced (Household Spending)	250	\$12.4
Total Economic Impacts	1,030	\$51.0

*Notes: Figures may not sum due to rounding. Commercial fishing labor income figures include estimated income from tender vessels owned by local residents.
Source: McDowell Group estimates based on ADF&G, DCCED, DOLWD, IMPLAN, NMFS, and industry interviews.*

The Kenai area -- including the communities of Clam Gulch, Kalifornsky, Kasilof, Kenai, Nikiski, Ninilchik, Soldotna, and Sterling -- contains the second-largest number of resident seafood processing workers and commercial fishermen of any other area in Southcentral Alaska (next to Anchorage/Mat-Su).

The Kenai fleet consists primarily of driftnet boats and setnet operations that harvest salmon from Upper and central Cook Inlet waters. Kenai area residents account for 43 percent of total participation in Cook Inlet salmon fisheries while other Southcentral residents account for 30 percent - a high percentage compared to other commercial fisheries in Alaska.

Fresh & Local Sockeye!

Kenai's seafood industry is highly dependent upon sockeye salmon from Cook Inlet. Due to Kenai's proximity to the Anchorage market and airport, most sockeye is brought to market as fresh product. This provides regional consumers with easy access to high-quality, fresh sockeye at lower prices than any other major U.S. market. Fishermen also get higher prices, because fresh salmon often sells at a premium to frozen product.

Cook Inlet sockeye is a win-win for Southcentral consumers and the Kenai economy.



F/V *New Wave* of Kasilof, Alaska.
Photo Credit: Alaska Salmon Alliance.

Local Seafood Business Profiles

Snug Harbor Seafoods

Started by local residents Paul and Brenda Dale in 1990, Snug Harbor Seafoods has grown into a major business with sales of \$25 to \$30 million per year. The company produces standard products such as frozen headed/gutted fish for wholesale clients, as well as fillets and smoked, canned, and jarred products.



They are a key supplier for the region's restaurants, supplying three directly and many more through Favco and 10th & M Seafoods in Anchorage.

The company typically buys fish from about 480 fishermen in the region. These fishermen participate in setnet, driftnet, seine, and longline fisheries in Cook Inlet, Prince William Sound, and the Gulf of Alaska. Snug Harbor employs about 500 seasonal processing workers and maintains a full-time resident staff of 15. The Dales estimate about 40 percent of the seasonal workforce are resident workers.

Pacific Star Seafoods

Pacific Star Seafoods is a wholly-owned subsidiary of E&E Foods. Companies owned by E&E Foods typically employ 350 workers at peak season in Southcentral Alaska. The company buys product from roughly 325 Southcentral fishermen.



Despite significant challenges in Kenai, E&E Foods has invested heavily in the region to build capacity. "This is the most competitive area of the state. We have to pay higher prices for fish because anybody with a truck can come and buy fish," says company president Tab Goto. The location and logistical options available in Kenai are good for fishermen and present more options for processors to add value, but also contributed to Ocean Beauty exiting the region. "We have invested very heavily in the Cook Inlet seafood industry, but all the companies and fishermen need a stable environment in order to grow and keep operations going into the future. Without access to the resource, there is no industry."

Goto notes the important role the commercial seafood industry plays in the regional and broader U.S. economy, "All this wonderful fish we get to catch ends up on somebody's plate; either in the region, the lower 48, or overseas. We share the bounty of Alaska with everybody."



Although Seward is a major seafood port, its strategic role in marine research, vocational training, and expanding marine support services for the greater Alaska seafood industry is even more important. Research efforts, training programs, and port investments based in Seward will greatly benefit the community, the region, and the state for years to come.

Seward's seafood industry supported an estimated 390 FTE jobs and \$19.3 million of labor income in 2013, including direct effects and secondary multiplier impacts. Fishermen from other parts of Alaska and the lower 48 earned an estimated \$33.0 million of labor income landing fish in Seward during in 2013.



2013 SNAP SHOT Seafood Industry

Seafood Industry Workers	670
Industry Dependent FTE Jobs	390
Total Area Population	2,500
Value of 2013 Local Landings	\$69.7 M
Industry Dependent Labor Income	\$19.3 M
Gross Earnings of Resident Fishermen	\$11.8 M
Value of Local Seafood Assets	\$50.7 M
Local Commercial Fishing Fleet (Number of Vessels Homeported)	67
Local Processing Facilities	10

Economic Impact of the Seafood Industry in Seward, 2013

	FTE Jobs	Labor Income (millions)
Resident Commercial Fishing	140	\$6.9
Seafood Processing	110	\$5.4
Direct Industry Total	250	\$12.3
Indirect (Business Spending)	80	\$4.1
Induced (Household Spending)	60	\$2.9
Total Economic Impacts	390	\$19.3

*Notes: Figures may not sum due to rounding. Commercial fishing labor income figures include estimated income from tender vessels owned by local residents.
Source: McDowell Group estimates based on ADF&G, DCCED, DOLWD, IMPLAN, NMFS, and industry interviews.*

Seward and Cordova are Southcentral's top commercial fishing ports, in terms of landed value. Over the past four years, each port has averaged about \$70 million in seafood landings. Increasing hatchery production of PWS pink salmon and a potential change to Gulf of Alaska groundfish management could present local fishermen and processors with new opportunities in coming years.

Nineteen percent of Seward's working age residents are estimated to have been directly employed in the seafood industry at some point in 2013. Seafood-related jobs make up about 27 percent of local employment (including multiplier effects).

Building a Bright Future

Emerging Shipyard Capacity

The Seward Marine Industrial Center (SMIC) has initiated work on a \$65 million expansion project which will add moorage and service capacity for large vessels, improve freight logistics on Alaska's road system, and significantly improve Seward's ability to service large fishing, tour, cruise, research, oil/gas, and shipping vessels operating in Alaska.

Vigor Alaska, a major shipyard operator in the Pacific Northwest, recently purchased the adjacent Seward Ship's Drydock facility and intends to invest heavily in the local workforce and facility.

Workforce Development & Training: AVTEC

AVTEC is state-run technical school located in Seward, serving roughly 1,300 students per year (some through remote learning programs). Nearly all AVTEC programs support Alaska's maritime and commercial seafood industry in some way.

Marine Research: ASLC & APSH

The Alutiiq Pride Shellfish Hatchery is working on a king crab enhancement program that could rebuild stocks which were overfished during the 1970s and 1980s. Meanwhile, the Alaska SeaLife Center provides visitors with a fun and educational tour of Alaska's marine wildlife and industry.

Local Seafood Business Profile

Icicle Seafoods

Icicle Seafoods has operated the Seward Fisheries facility since 1978. The plant processes salmon, halibut, black cod, and Pacific cod, and features four canning lines. The company employs up to 350 workers in Seward during peak summer months and employs an average of 120 workers per month throughout the entire year. Icicle provides on-site housing to accommodate seasonal workers. Although most workers are seasonal hires the plant employs approximately 30 Seward residents, primarily in managerial, administrative, and higher-skilled technical or production positions.



Icicle Seafoods is by far the largest processor in Seward, providing a market for hundreds of commercial fishermen participating in seine, gillnet, and longline fisheries. The company and fishermen serviced by the plant spend over \$4 million a year in the local economy, indirectly creating jobs in Seward. Seward's position on the road system, proximity to Anchorage, and access to substantial seafood resources present opportunities for growth.





Valdez is a growing seafood port and pink salmon is the primary resource. It is estimated that Alaska’s seafood industry directly employed 740 workers and supported a total of 340 FTE-jobs in Valdez during 2013 (including direct and secondary effects). The industry contributed about \$620,000 in fisheries tax revenue to the City in 2013.

The oil industry drives the local economy, but seafood and the tourism industry are becoming increasingly important segments. It is estimated that 10 percent of working age residents worked in the seafood industry at some point in 2013 (not including those who lived in group quarters).



2013 SNAP SHOT Seafood Industry

Seafood Industry Workers	740
Industry Dependent FTE Jobs	340
Total Area Population	4,100
Value of 2013 Local Landings	\$28.7 M
Industry Dependent Labor Income	\$16.7 M
Gross Earnings of Resident Fishermen	\$5.4 M
Value of Local Seafood Assets	\$19.6 M
Local Commercial Fishing Fleet (Number of Vessels Homeported)	56
Local Processing Facilities	3

Economic Impact of the Seafood Industry in Valdez, 2013

	FTE Jobs	Labor Income (millions)
Resident Commercial Fishing	70	\$3.4
Seafood Processing	180	\$8.8
Hatchery & Mgmt.	20	\$0.9
Direct Industry Total	260	\$13.0
Indirect (Business Spending)	40	\$2.1
Induced (Household Spending)	35	\$1.7
Total Economic Impacts	340	\$16.7

*Notes: Figures may not sum due to rounding. Commercial fishing labor income figures include estimated income from tender vessels owned by local residents.
Source: McDowell Group estimates based on ADF&G, DCCED, DOLWD, IMPLAN, NMFS, and industry interviews.*

Valdez is home to 102 local resident commercial fishermen, while the processing sector and VFDA salmon hatchery employ roughly 100 Alaska residents. Despite the significant number of jobs created for Alaska residents, many seafood jobs in Valdez are currently filled by residents of other states. As the seafood industry grows and matures in Valdez, substantial career opportunities will be available to local residents.

The commercial fishing fleet consists of 56 vessels which homeport in Valdez, as well as numerous seiners that homeport elsewhere but deliver fish to Valdez’s two large processing plants. Many of these boats also participate in longline IFQ fisheries for halibut and black cod.

Tapping a New Source of Growth

The seafood industry is growing faster in Valdez than any other Southcentral community. Both Peter Pan Seafoods and Silver Bay Seafoods, the two main processors in the community, have plans for significant expansion in the near-term. These projects are related to increased pink production from the two regional salmon hatcheries (VFDA and PWSAC). The City of Valdez is working to relieve marine congestion through a major harbor expansion project, including 320 new slips. These projects will present significant economic opportunities for residents of Valdez and other Southcentral communities.

Local Profile

Peter Pan
Seafoods



In a unique joint venture, Peter Pan Seafoods and Trident Seafoods plan to build a salmon oil plant adjacent to the current Peter Pan facility in Valdez. When complete, the addition will be capable of processing salmon heads (and potentially other unused fish parts) into high quality salmon oil suitable for human consumption.

The fish oil plant would be built and owned by Peter Pan and leased to Trident Seafoods, which would operate the plant and supply necessary equipment. Trident Seafoods sells salmon oil capsules under its Pure Alaska Omega brand. The product is sold in all Costco locations and most Sam's Club stores.



The Alaska Salmon Alliance would like to thank the following companies for their support in sponsoring this landmark research project:



The Alaska Salmon Alliance contracted with McDowell Group to analyze the seafood industry's economic impact in Southcentral Alaska. This report quantifies the direct, indirect, and induced economic effects of the commercial seafood industry in Southcentral as a whole, and examines impacts at community or sub-region level for six areas in the Southcentral region. Analyses of the industry's impact on the shipping sector and a profile of salmon harvests by user group are also included in this report.



Download the full report at www.aksalmonalliance.org/

ANNOUNCEMENTS
PRESENTATIONS
BOROUGH REPORT
COMMISSION REPORTS

**CITY OF HOMER
HOMER, ALASKA**

MAYOR'S RECOGNITION

HOMER HIGH WRESTLING TEAM

WHEREAS, On December 12, 2015, the Homer High School Wrestling Team earned first place at the Kachemak Conference Region III Tournament; and

WHEREAS, On December 19, 2015, the Homer High School Wrestling Team earned first place at the Small Schools Alaska State competition; and

WHEREAS, It had been 29 years since the Homer High School Wrestling Team had earned a state championship; and

WHEREAS, Homer High School Wrestling Team earned three individual State Champions: Freshman McKenzie Cook (145), Junior Timmy Woo (152) and Sophomore Levi King (195); and

WHEREAS, The Homer High School Wrestling Team placed 16 out of 18 individual wrestlers in the top six in their respective weight classes; and

WHEREAS, The Homer High School Wrestling Team finished with 3 first place finishers, 4 second place finishers, 5 third place finishers, 1 fourth place finisher, 2 fifth place finishers, and 1 sixth place finisher; and

WHEREAS, Each team member has devoted countless hours off season training through weight training, attending camps, and participating in the Homer Popeye Wrestling and Anchor Kings Wrestling Clubs; and

WHEREAS, Coach Bubba Wells has been selected as the Alaska Assistant Wrestling Coach of the Year; and

WHEREAS, Coach Chris Perk has been selected to be Region III Wrestling Coach of Year and he was selected as the Alaska Wrestling Coach of the Year.

NOW, THEREFORE, I, Mary E. Wythe, Mayor of the City of Homer, do hereby recognize the

HOMER HIGH WRESTLING TEAM FOR EARNING FIRST PLACE AT THE ALASKA STATE COMPETITION

IN WITNESS WHEREOF, I have hereunto set my hand and caused the Seal of the City of Homer, Alaska, to be affixed this 11th day of January, 2016.

CITY OF HOMER

MARY E. WYTHE, MAYOR

ATTEST:

JO JOHNSON, MMC, CITY CLERK

From: [Mike Illg](#)
To: [Jo Johnson](#)
Subject: State Wrestling Wrap Up
Date: Tuesday, January 05, 2016 2:47:10 PM

I also wanted to share this with you and whomever may be interested. An amazing group of hard working local youth, many if not all have started wrestling with Community Rec's Popeye Wrestling program.

Thanks,

mike

From: Chris Perk
Sent: Monday, December 21, 2015 11:15 AM
Subject: State Wrestling Wrap Up

Homer Wins State Championship
16 out of 18 athletes place in top 6

The Mariner Mat Team locked up the Small Schools State Title before the Finals matches even began. In the first round of the State Meet, all 11 Homer wrestlers earned pins giving them 44 points. Those 44 points is what the team needed as they beat Bethel who had won 4 of the last 5 tournaments. Leading the way was Timmy Woo at 152 pounds. Woo dominated his way to the finals against Craig's Wyatt Patton. Patton who lost to Woo in the ACS finals took a quick 2-0 lead, but Woo wasted no time and before the end of the first period he had regained the lead 5-3. Woo went on to win 11-7. He finished the season with 160 takedowns a new school record. Levi King also earned the Title of State Champion at 195 pounds. King earned the Title before Friday night was done as his opponent was injured in a match and not able to wrestle in Saturday's Final round. King was seeded fourth and earned two quick pins before a rematch with Malaki Barratt from Houston the #1 seed. Barratt crushed King in the Conference Tournament the week before. This time however, King went into the match with more confidence knowing that if he could win this match, he would be a State Champion. Barratt took King down right away, but then locked his hands and gave King a point for a technical violation, this seemed to throw Barratt off mentally and then let King go for an escape, King then look Barratt down and was tied up at 4-4 after one period. The match continued back and forth until King put Barratt to his back for near fall and was leading 9-5 before Barratt scored a 2 pt takedown and almost near fall when the final whistle blew and King earned a hard fought 9-7 victory. King was our second string 170 pounder who was giving up at least 20 pounds. Levi totally accepted the opportunity to fill the weight class that HHS was missing and turned it into a Championship.

In only the second year of the Girls State Championship, Homer had all six girls place in the top 5 of their weight classes. No team scores were kept this year as it is still considered an emerging sport. Freshman McKenzie Cook 145 took home the Top Honors as State Champion. In one of the toughest weight classes, Mckenzie had to win six matches in route to her title. Since the girls

brackets are not seeded, they have a wrestle back for anyone who loses. Cook lost to Angela Peacock on Friday night 5-0. But then got a rematch on Saturday and earned a pin sending Cook to the finals against Hailey O'Brien from Bethel. O'Brien a Senior had beat Cook in Bethel the first week of the season. Cook would not be denied as she dominated from start to finish and won 7-2. Senior Jadzia Martin 106 and Junior Heather Harrington 220 both were Finalists in their weight classes. Martin had a great season winning 25 matches and had won four matches going into the finals against Kailey Fowlkes from North Pole. Martin had beaten Fowlkes the day before 8-2 but in the finals Fowlkes earned a 5-1 victory. Freshman Katie Rios 160 placed 3rd and Allison Wells 120 placed 5th. Sophomore Alex Moseley 113 placed 4th winning 3 matches. We are looking forward to more girls meets next season.

Other boy finalists were Wayne Newman 98 and Jared Brant 132. Newman and Brant both had Bethel opponents in the final and both had split with wins and losses for the season. Newman battled back after giving up and early takedown and nearly pulled off a win but was taken down in the final seconds as Thomas Dymont defended his Title 10-9. Those two are a lot of fun to watch, I think if they were to wrestle again, Newman wins it, the two are that close every match. Brant who had a stellar season as well, scored the first takedown, but was unable to secure an escape in the third period, forcing an overtime period. In the final seconds of the that period, Brant attempted a throw but Aaron Olson was able to counter with only a second remaining and winning 4-2. Both wrestlers won over 35 matches this season.

The total domination round happened when many of the wrestlers were battling back for third/fourth and fifth/sixth place. Freshman Luciano Fasulo 120, who like Newman is a lot of fun to watch wrestle, put the #1 seeded wrestler from Kotzebue on his back in the semi-finals but it was not enough and dropped into the consolation bracket. There Luciano wrestled Jared Virgin from Glennallen for third place. Virgin had beat Fasulo twice this year. Fasulo scored first and then was able to counter and even put Virgin on his back to secure a 6-2 win. He won 44 matches this season and broke the school Reversals record with 46, it was 40 held by former State Champion John Neland in 1987. Then Jaime Rios 145 and Teddy Croft 160 were wrestling at the same time in a couple of close and exciting matches, Rios used a last second reversal to beat Zeke Eakin from Kotzebue 6-5 and place 5th. He was also a fifth place finisher last season. Croft just a Sophomore, pinned Titus Tripple who only had two losses on the season and had beaten Croft in their only meeting at ACS a month ago. This time though Croft had a good game plan and was able to put Tripple to his back and pin him with only a minute left in the match. Then Tristen Cook 170 and Kyle Wells 182 followed up with decisions as well. Cook beat Trey Henning 7-0. Cook won 44 matches this season and nearly made it to finals, but lost a tight match to his nemesis Nathan Carstens from Nikiski. Wells beat Drew Pekkar from Bethel 6-4. Wells battled a muscle strain most of the season and was able to finish the season earning big points for the Mariners. The final placer for the team was Jadin Mann at 220. The Freshman earned a 6th place finish in a heavily dominated weight class of upper classman. Seth Inama 106 and Tyler Johnson 145 both won matches for the team and will be in contention to place next season.

The team had an outstanding finish to a superb season. Much of the credit can go to Assistant Coach Bubba Wells, who was voted outstanding "Assistant Coach of the Year". This title is very

deserving as he will coach the Chapman Middle School team from January to February and then coach the Anchor Kings Youth team until May. He is truly the glue that keeps this team together. He has formed a great relationship with the athletes and is so dependable. Coach Perk was also selected "Head Coach of the Year" for the teams achievement. This is voted on by the Coaches. This team will return 15 state placers. The future battle with Bethel the next few years will be fun to watch, they only graduate one senior as well.

Session 15-18, a Regular Meeting of the Homer Advisory Planning Commission was called to order by Chair Don Stead at 6:33 p.m. on December 2, 2015 at the City Hall Cowles Council Chambers located at 491 E. Pioneer Avenue, Homer, Alaska.

PRESENT: COMMISSIONERS ERICKSON, HIGHLAND, BRADLEY, STEAD, STROOZAS,
AND VENUTI

ABSENT: COMMISSIONER BOS (EXCUSED)

STAFF: CITY PLANNER ABBOUD
DEPUTY CITY CLERK KRAUSE

APPROVAL OF AGENDA

Chair Stead requested a motion to make the changes as requested by the City Planner.

ERICKSON/VENUTI - MOVED TO AMEND THE AGENDA TO REMOVE STAFF REPORT PL 15-80, ZONING FOR MARIJUANA FROM PUBLIC HEARINGS ITEMS 8 C TO PENDING BUSINESS ITEM 10 A AND STAFF REPORT PL 15-83 TOWER CONSIDERATIONS TO PENDING BUSINESS ITEM 10 B.

There was no discussion.

VOTE. YES. NON-OBJECTION. UNANIMOUS CONSENT.

Motion carried.

Chair Stead called for a motion to approve the amended agenda.

STROOZAS/BRADLEY - SO MOVED.

There was no discussion.

VOTE. YES. NON-OBJECTION. UNANIMOUS CONSENT.

Motion carried.

PUBLIC COMMENT

The public may speak to the Planning Commission regarding matters on the agenda that are not scheduled for public hearing or plat consideration. (3 minute time limit).

Chair Stead opened the floor for public comment on regular agenda items.

Kevin Dee, resident, commented on Pending Business Item 10 B. Towers Considerations; he appreciated the information included in the packet, complimented the City Planner for providing the information from the Municipal Solutions Group that points out the technical aspects of towers that really need to be reviewed by experts. He appreciated the graphical evidence in the report showing manipulated propagation map, collapsed towers and all the rest. With the reduced budgets of the Planning Department have the tower companies who want to put up a tower pay for analysis of their proposals; he appreciates the ordinance requiring a technical review and many of the requirements in the model ordinance submitted by Municipal Solutions.

City Planner Abboud reminded the audience that the commission has removed the Public Hearing Item on Marijuana Zoning since it was not noticed properly and this is the time to comment on that topic.

George Frazier, resident, commented that he is a trained industry professional and looking forward to the progress of the cannabis industry developing on the lower Peninsula.

RECONSIDERATION

ADOPTION OF CONSENT AGENDA

All items on the consent agenda are considered routine and non-controversial by the Planning Commission and are approved in one motion. There will be no separate discussion of these items unless requested by a Planning Commissioner or someone from the public, in which case the item will be moved to the regular agenda and considered in normal sequence.

A. Approval of the minutes of November 4, 2015 meeting

Chair Stead requested a motion to approve the consent agenda.

HIGHLAND/BRADLEY - SO MOVED.

There was no discussion.

VOTE. YES. NON-OBJECTION. UNANIMOUS CONSENT.

Motion carried.

PRESENTATIONS

REPORTS

A. Staff Report PL 15-77, City Planner's Report

City Planner Abboud provided a summary of his report. He noted the following:

- the Public Hearing for Marijuana Zoning did not get properly advertised, if any changes are made tonight then a second public hearing will be held at the January 6, 2016 regular meeting of the commission.
- City Council passed the ordinance for Bridge Creek
- City Council also discussed how the HART Funds were allocated regarding sidewalk down Soundview and the Planning Commission may be asked to review policy at some point.
- The Chamber of Commerce will be installing an informational kiosk at the Baycrest Overlook. This has been in the works for a few years.
- The All Hazard Mitigation Plan is posted on the Planning webpage for comment and review. Council person Reynolds continues to provide the Council with updates and will be sponsoring a resolution in January to adopt the plan.
- If you will not be here for the January 6th meeting please let staff know.
- Interesting and informational annual conference this year, they also had a presentation by Cynthia Franklin with the Marijuana Control Board.

PUBLIC HEARINGS

Testimony limited to 3 minutes per speaker. The Commission conducts Public Hearings by hearing a staff report, presentation by the applicant, hearing public testimony and then acting on the Public Hearing items. The Commission may question the public. Once the public hearing is closed the Commission cannot hear additional comments on the topic. The applicant is not held to the 3 minute time limit.

A. Staff Report PL 15-78, Conditional Use Permit 15-06, 4242 Calhoun Street Construction of Four (4) Duplexes in the Urban Residential District

Chair Stead read the item into the record. Commissioner Venuti declared a possible conflict of interest.

STROOZAS/BRADLEY - MOVED THAT COMMISSIONER VENUTI HAS A CONFLICT.

A brief discussion on the limits of monetary gain for Commissioners and if Mr. Venuti had reached those levels ensued.

VOTE. NO. HIGHLAND, BRADLEY, ERICKSON, STEAD, STROOZAS

Motion failed.

Commissioner Erickson disclosed that she may have a conflict of interest as they are family friends.

Commissioner Stroozas asked if Commissioner Erickson if she was unable to provide an unbiased decision.

HIGHLAND/VENUTI - MOVED THAT COMMISSIONER ERICKSON MAY HAVE A CONFLICT.

There was a brief discussion.

VOTE. NO. STROOZAS, VENUTI, STEAD, BRADLEY, HIGHLAND

Motion failed.

City Planner Abboud reviewed his report for the record noting the following:

- 4 duplexes for a total of 8 dwellings
- Total of 1.89 acres/82,328 sf
- Zoning is Urban Residential
- Existing land is vacant
- Residential Areas and Vacant land surround this parcel
- No designated wetlands
- Flood Hazards are undetermined
- Notice was sent to 50 property owners
- City Utilities are available
- Not within the Bridge Creek Watershed Protection District

The applicant proposes to build four buildings. Each building will have two dwellings for a total of eight. There will be two designs/styles. Two structures will have single story units and two structures will have a one story structure and a two story structure.

Total Floor area is 10,888 sf which is under the 40% requirement. Staff has calculated the open area as more than 61,000 sf. This proposal provides ample open space and exceeds the requirement. The value of the adjoining property will not be negatively affected than any other permitted or conditionally permitted uses in the district. The surrounding properties are mainly single family homes on 9,000 to 20,000 sf lots. The proposed development is approximately one dwelling per 10,000 sf so the density is very similar. This is compatible with existing uses in the area and requiring connection to city services of water and sewer. This development is not expected to cause a greater amount of traffic. There is a down lit lighting requirement. The developer plans to leave as many trees as possible and is working closely with the city Public Works department.

Chair Stead asked if the applicant was present and wished to speak at this time.

Josiah Fisher, applicant, stated he was interested in hearing everyone's opinion, he has no plans to ruin the neighborhood and plans to preserve the vegetation and trail as much as possible.

Commissioner Highland requested information on the effects of the proposed project on the trail if any.

Mr. Fisher responded that he is required to construct a 20 foot wide driveway. The city also has specific areas and placement for the utilities.

Chair Stead opened the public hearing.

Justin Wickstrom, property owner resident on Svedlund Circle, his property borders the proposed development, expressed concerns regarding how it will be developed, rentals versus single family

homes, losing the value to his property, he recommends fencing to border the property, and creating more traffic in the area.

Patrick Church, resident Calhoun Court, commented that the proposed duplex complex and the impact on the immediate neighborhood please consider the following conditions regarding items 5 and 6 of Analysis, page 13 of the application:

1. That the Conditional Use Permit presupposes that the permit is conditional as the name implies.
2. That the proposed 20 foot driveway be constructed at the east side of the 60 foot right-of-way to minimize any conflict with the existing trail.
3. That the provisions are adopted to provide for Calhoun Trail to be suitably re-located west if Calhoun Trail is affected by the driveway placement and snow removal or berms.
4. That being Calhoun Street is not a through street, a 10 mph speed limit be placed on its vehicular traffic.
5. That planning is necessary to determine that the project needs further study regarding due consideration given to the preservation of access and current usage of Calhoun Trail without vehicular interference or contact with pedestrians before the CUP is granted.

As a concerned citizen living within 300 feet of the proposed project I ask that these conditions be considered and approved and believe that there will be less impact on the community. He additionally asked if there would be any additional hearings for this CUP. Mr. Church then continued on specific measurements for the trail.

Beth Cumming, resident on Gavin Court, commented regarding increase in population density not being appropriate within the surrounding area. The proposal reduces the area per family to 1/3 to ¼ acre; she also had concerns about renters versus homeowners. It has been proven that renters have less concern over the property than owner occupied homes. This land has no covenants; she referenced the covenants of nearby similar neighborhoods and noted that beyond this meeting this matter will not go before the council.

Rick Foster, member of the Borough Planning Commission, former Planning Commissioner, reminded the commission that this commission can make any reasonable requirement such as painting all houses pink. The previous city attorney stated that as long as you have good reasons for those conditions.

Mike Dye, resident, commented that he did not believe that this issue has not been properly reviewed. He cited the population density being over the neighborhood needs and four duplexes is more than what is needed for this area. He referred to comments in the packet regarding that this issue needs additional analysis before moving forward. The comparative use of a railroad was not appropriate. Mr. Dye questioned the property access from Danview over Bayview. The neighborhood concerns should be considered over the property developers. He was not sure why they were going out of their way to avoid well developed processes. He additionally questioned the trail and effect on the project.

Beau Burgess, resident, owner of the adjoining lot, he responded to a question of closing the trail he would not want to see that closed either. He has personally spoken to Public Works and they are specific that the driveway be 20 feet and centered in the PW is very specific for safety reasons; accessing from Bayview instead Danview is the distance is shorter and thus less impact on the trail. He felt that the applicant has been very careful in planning. He requested the property owners consider the larger issues, this is urban residential and as such this should be the highest density area of the city and they lack housing. Mr. Burgess also spoke on the density issues and noted that the project has the same overall density as every surrounding property.

Jenny Medley, resident, understands the value of owner occupied however Homer has a distinct shortage of nice rental properties that are within walking distance of all the great things that make Homer great. There are a number of young people that live outside the city, paying high rents for tiny cabins and no utilities. She believed that this would be a good thing to have.

John Thompson, resident on Svedlund Circle, commented on the fencing in the east side and south side of the property and wanted to know what the height of the fencing would be, he has 250 feet

bordering this property and does not want to put up with people who cut across his property, Mr. Thompson also expressed concerns regarding concerns regarding lighting.

Carol Standart, resident, expressed concerns with lighting since this will be in her backyard, and she heard that the project may eliminate the trail. She cannot tell from the plans how all the trees will be saved.

Carol Coleman, resident on Bayview, opposed against having renters and losing the use of property as a playground for their kids. She was opposed to the unknown behaviors of the renters children and the property having no covenants when they have strict ones.

Michelle Lennan, resident, commented knowing that when she bought her home someone would build a home there but building multi-family homes for people who don't value the property as much as a single family home owner would and she also expressed concern on losing the trail.

Kristy Wickstrom, resident, maps received don't show the correct property lines, one corner of her property butts up to this project, she is not opposed to development but she disagrees that there will be no negative impact on the area which she disagrees. There will be 8 additional families, possibly 16 additional vehicles, she noted that some renters really take care of their homes but most don't and she has a preference single family. Mrs. Wickstrom acknowledged the need for housing but not in her back yard and not four duplexes, two she could support.

Catriona Reynolds, resident, wanted to put a green dot on this meeting and commented that renters are people that need homes too and can be just as good neighbors as anyone else and to categorize renters as what kind of families we don't know what they are, she thinks is very disappointing and not something she is proud of her community.

Lindianne Sarno, resident, commented on trails, safety, the common theme that is coming through is to continue to develop the charm and safety of Homer. The solution is taking an endless progression of single family homesteads throughout the neighborhoods forever which becomes a foundation powered by the young people who want to create homestead businesses, incubating small businesses, empowering them to do for the community on this charming landscape, it is not safe, this is a scary place for a kid, she appreciates the efforts to build the bridges of Homer.

Seeing no more public comment Chair Stead closed the public hearing.

Rebuttal to comments made during Public Hearing:

Josiah Fisher, applicant, stated he has lived in a couple of neighborhoods in Homer, plans to reside in one of the units that will be built. He plans to enact very strict rental agreements which will be rigorously enforced. He understood the concerns expressed on the unknowns with tenant behavior. This is less density than current lots on Bayview.

Commissioner Questions, Comments, Concerns:

Commissioner Erickson questioned the following: drainage issues on the property, type of renter will be targeted; and if the applicant was related to Timothy Fisher?

Mr. Fisher commented that the planned 3 bedroom unit in the far northeast unit is for his family; six of the units are two bedroom, and are more for the older renters and single professionals. He has expended time in planning diligently to address drainage issues and he stated he is not related to Timothy Fisher.

Commissioner Highland requested clarification on the placement of the driveway in relation to the trail. Mr. Fisher using the large map showed that it would proceed north in the middle of the easement/trail, utilities will be placed underground, there should be room but it is up to the public

works department as to determine the location of the driveway within the area indicated. Mr. Church requested by the Commission, using the map assisted by indicating where the trail was according to the information he provided. Mr. Fisher noted that he will build the driveway wherever the Commission dictated.

Commissioner Highland stated for clarification that the parcel is 1.88 acres, there will be 4 duplexes which she is aware that it make it appear to present a higher density, but does not and the district allows this project by the conditional use process, and the City Planner has shown that there is ample room. Chair Stead requested a motion so they can discuss this application.

VENUTI/HIGHLAND - MOVED TO ADOPT STAFF REPORT PL 15-78, CUP 15-06 FOR FOUR DUPLEXES AT 4242 CALHOUN STREET.

Discussion on the placement of the driveway and preserving the existing trail; making conditions for the developer; requiring offsite improvements to have the trail and driveway co-exist; buffer concerns; lighting requirements; a phased project build-out but application is for the entire project to go through the process one time ensued.

HIGHLAND/VENUTI - MOVED AMEND THE MOTION TO ADD THE REQUIREMENT THAT THE OWNER/DEVELOPER WORK WITH PUBLIC WORKS TO DEVELOP A DRIVEWAY TO COEXIST WITH THE TRAIL ON CUP 15-06.

There was a brief discussion and clarification on the intent of the motion.

VOTE. (Amendment) YES. NON-OBJECTION. UNANIMOUS CONSENT.

Motion carried.

Commissioner Venuti commented on the resistance to tenants and acknowledged the existing large multiple family rental units in the area and is of no concern. He further stated that due to economic circumstances some persons must rent and there is no detriment to the community. This would not be unique to the area.

Commissioner Stroozas echoed the sentiment regarding renters and noted the Coast Guard housing nearby.

Commissioner Bradley reiterated the comments of Commissioner Highland and others that this project fits perfectly and is in favor of rental housing and there is a great need in Homer. This project is in alignment with the goals for the area and on a personal note she would be a perfect candidate since she is a young professional having a graduate degree and would rent one of these units.

Commissioner Stroozas commented on the opposition of this project by residents and that the commission must follow what the City Code says and since this project falls within the code they have no reason to deny the permit.

Chair Stead requested clarification on high the fence and type is planned for the project. Mr. Fisher responded that he will build it as high and as long as allowed. It will be a wood privacy fence at least 5 foot in height. He stated that the fence is to keep his kids from other property owners yards.

Commissioner Erickson asked if the CUP stays with the property if it is sold in the future.

City Planner Abboud responded that it generally stays with the property unless they add a sunset clause but they do not generally use sunset clauses here. He responded to Commissioner Stead regarding fencing and maintaining such fencing.

STROOZAS/HIGHLAND - MOVED TO AMEND THE MOTION THAT CONDITION THREE BE ADDED THAT THE APPLICANT BE REQUIRED TO ERECT A FENCE ALONG THE ENTIRE EAST SIDE OF THE PROPERTY.

Discussion ensued regarding adding a height requirement for the fence. The commission requested input from the applicant that the area motioned to be fenced is filled with very dense trees and would advocate for fencing up to the trees.

HIGHLAND/ VENUTI - MOVED TO AMEND THE AMENDMENT TO INCLUDE, INSTALLATION OF A FIVE FOOT FENCE FROM THE SOUTHEAST CORNER TO THE TREES THAT PROVIDE AN IMPASSABLE BARRIER ON THE EAST SIDE.

There was no additional discussion.

VOTE. (Amendment to the Amendment) YES. NON-OBJECTION. UNANIMOUS CONSENT.

Motion carried.

Chair Stead asked for any additional amendments or discussion on the amended motion.

VOTE. (Amendment). YES. NON-OBJECTION. UNANIMOUS CONSENT.

Motion carried.

Chair Stead then asked if there was any additional discussion on the issues of lighting. There was a brief discussion on lighting which the City Planner stated is included in the staff recommendation.

Commissioner Erickson asked about inclusion of a sunset clause. City Planner Abboud was not supportive of including a sunset clause.

Chair Stead asked the Clerk to do a roll call vote.

VOTE. (Main as Amended) YES. HIGHLAND, BRADLEY, ERICKSON, STEAD, VENUTI, STROOZAS

Motion carried.

B. Staff Report PL 15-79 Vacation of Easement - Waddell Way/HEA

Chair Stead read the item into the record. City Planner Abboud reviewed his report noting the following:

- Vacation of an Easement at Waddell Way and Lake Street
- Central Business District
- Notice sent to 32 property owners
- The Commission has already approved the preliminary plat for the project
- Dedicate 30 feet of right of way to allow construction of Waddell Way to city standards
- this easement is no longer needed by the city
- Access is dedicated and property owner is working with the city prior to upgrading Waddell Way
- there are no issues for the Fire Department

Chair Stead opened the public hearing. Hearing no public comment the hearing was closed.

ERICKSON/BRADLEY - MOVED TO ADOPT STAFF REPORT PL 15-79 TO APPROVE THE VACATION OF EASEMENT ALONG WADDELL WAY.

There was a brief clarification that the easement was already being used as equipment storage by HEA.

VOTE. YES. NON-OBJECTION. UNANIMOUS CONSENT.

Motion carried.

Chair Stead called a brief recess at 8:24 p.m. The meeting was reconvened at 8:28 p.m.

C. Staff Report PL 15-80 Zoning for Marijuana

This item was not properly advertised for Public Hearing and moved to Pending Business, Item 10. A

D. Staff Report PL 15-82 CUP 15-07 at 1242 Ocean Drive in the General Commercial 1 District

Chair Stead read the title into the record. City Planner Abboud reviewed the application for a CUP in the location of the former Quickie Mart for more than one building containing a permitted principle use on a lot and a planned unit development to reduce the setback from Ocean Drive. He noted the following points:

- There were several buildings, and vehicles on the property
- General Commercial 1 District
- Compatible to the surrounding land uses
- No designated wetlands and flood hazards are undetermined
- City utilities are available but not connected
- Notice was sent to 25 property owners
- The canopy was not permitted or the building currently in construction under the canopy.
- Several violation notices have been issued to the owner
- The owner plans to add a second story to the building under construction under the canopy
- Fire Chief has stated that the project has been in violation since it started and applicant has applied for Fire Marshal review which has been stalled and delayed. The Fire Chief is not in favor of permitting after the fact projects.
- The application is not valid without Fire Marshal certificate.

Staff recommendation was to approve CUP 15-07 with Findings 1-19 and Conditions 1-7

Chair Stead invited the applicant to comment to the commission.

Guy Chow, applicant, stated he would like to have the project approved and continue moving forward. He understood the changes that would be required and believed that the project would fill a big hole along Ocean Drive.

Chair Stead opened the Public Hearing. There were no public comments. The public hearing was closed. Chair Stead requested a motion to open discussion. The commission had a few questions for the applicant first. Items or issues questioned were as follows:

- old underground fuel tanks, condition/status and location
- type of foundation of the new structure under the canopy
- why Fire Marshal approval was not obtained prior to construction
- ability to connection to city utilities by the deadline date of December 31, 2015
- Why did he not use the old Quickie Mart building and what his plans were for the structure
- What his plans were for the location
- If he felt it was feasible to obtain Fire Marshal approval within 45 days
- Addressing the concerns expressed by adjoining property owners regarding the conditions on the property and prior complaints regarding sanitation and restroom facilities
- the intent was to open by spring of next year
- Request to extend the date to May to meet the setback requirements

HIGHLAND/ BRADLEY - MOVED TO ADOPT STAFF REPORT PL 15-82, CUP 15-07 at 1242 OCEAN DRIVE IN THE GENERAL COMMERCIAL 1 DISTRICT WITH CONDITIONS 1-7 AND FINDINGS 1-19.

VENUTI/STROOZAS - MOVED TO AMEND THE MOTION TO POSTPONE THE ACTION FOR 45 DAYS TO ALLOW THE APPLICANT TIME TO RECTIFY THE PROJECT FOR FIRE MARSHAL APPROVAL.

Discussion on obtaining the requirements established by the Fire Marshall, and arguing that they could approve the CUP with the Fire Marshal approval contingent, the commission debated the best approach that benefits and follows the life, health and safety issues. Staff explained that they are at the point that it is an enforcement issue and questions what happens if compliance is not followed through on by the applicant. Commissioners advocated for promoting business and adding conditions to allow the applicant to proceed.

Commissioner Erickson called for the question. Commissioner Highland requested the Clerk to read the motion on the floor.

VOTE.(Amendment) NO. STROOZAS, STEAD, ERICKSON, BRADLEY, HIGHLAND
YES. VENUTI

Motion failed.

ERICKSON/HIGHLAND - MOVED TO AMEND THE MOTION TO EXTEND THE DATE ON CONDITION NO. 6 TO MAY 1, 2016; ADD CONDITION NO. 8 THAT THE CONDITIONAL USE PERMIT IS CONTINGENT UPON FIRE MARSHAL APPROVAL OBTAINED IN THE 45 DAYS TIME LIMIT; ADD CONDITION NO. 9 THAT AN OPERATIONAL RESTROOM IS ONSITE BY MAY 1, 2016 AND ADD CONDITION NO. 10 DESIGNATED PARKING BEFORE MAY 1, 2016

Discussion on adding the condition regarding operational restrooms is to address the issues caused by previous occupants/tenants on the property and the designated parking was to address the issues brought forward by the Day Care facility. Discussion also included the feasibility of obtaining Fire Marshal approval within the 45 day period.

HIGHLAND/ERICKSON - MOVED TO AMEND THE FIRE MARSHAL APPROVAL TO 90 DAYS.

Discussion ensued on the approval process and that the applicant is comfortable with the 45 day approval requirement.

VOTE. (Secondary Amendment) NO. NON-OBJECTION. UNANIMOUS CONSENT.

Motion carried.

Chair Stead clarified the additional conditions that were stated in the motion.

VOTE. (Primary Amendment) YES. NON-OBJECTION. UNANIMOUS CONSENT.

Motion carried.

Commissioner Highland requested they extend the time of the meeting at this time.

HIGHLAND/BRADLEY - MOVED TO EXTEND THE MEETING TIME TO 10:00 PM

There was no discussion.

VOTE. YES. NON-OBJECTION. UNANIMOUS CONSENT.

Motion carried.

Chair Stead then inquired if there was any further discussion on the main motion as amended to approve the Conditional Use Permit. There was no further discussion. Chair then asked for a roll call vote on the motion.

VOTE. (Main as Amended) YES. HIGHLAND, BRADLEY, ERICKSON, STEAD, STROOZAS
VOTE. NO. VENUTI.

Motion carried

PLAT CONSIDERATION

A. Staff Report PL 15-81 Tsunami View No. 2

Chair Stead read the title into the record. City Planner Abboud reviewed his report. He noted the following:

- there may be a levy of assessments for the Natural Gas Special Assessment District to the this decision.
- this is located north and west of Bayview park
- Rural residential District
- No wetlands
- City utilities available
- Notice was sent to 75 property owners
- require a 15 foot utility easement adjacent to Right of Way
- Noted comments from Public Works regarding access and the steep grade
- Fire Department concerned with access

No Applicant was present to comment or to answer questions.

Chair Stead opened the public hearing. Hearing no comments the public hearing was closed and the Chair requested questions for the City Planner.

The commission asked questions of the City Planner on the viability of the hillside and expressed concerns with maintaining the stability of the hillside, noted that construction on the steep slope would be limited, and expressed concerns of the access by the Fire Department, and questioned if they can put conditions on the plat to accommodate the Fire Department and the comments from Public Works.

VENUTI/HIGHLAND - MOVED TO ADOPT STAFF REPORT PL 15-81 TSUNAMI VIEW NO 2 WITH STAFF RECOMMENDATIONS 1-7

The commission held additional discussion on the steep slope issues.

VOTE. YES. NON-OBJECTION. UNANIMOUS CONSENT.

Motion carried.

PENDING BUSINESS

A. Staff Report PL 15-80 Zoning for Marijuana

Chair Stead read the title into the record. Staff teleconferenced in City Attorney Wells to the meeting.

City Planner Abboud stated that they combined the two items into one and they are running out of time having extended the time of the meeting to 10:00 p.m. He reported on the changes to the state regulations and that may bring about changing other rules; he still has concerns with bringing this issue of commercial grow operations in a Rural Residential Area, there are places to do business and that business does not belong in residential. He also doesn't believe that it should be allowed by CUP since that may open them to litigation. He stated that with the regulations imposed by the state the industry

will take care of itself. If they become too stringent and put too many limitations then they will end up with it on the outskirts of town and not have any of the benefits. The City Attorney recommended trying it a smaller area without having another layer of rules on top of the state's. City Planner Abboud stated that as far as limiting licenses there were concerns in limiting licenses without incurring litigation, the state handles the alcohol licenses and how would they choose or select who will get the license would open the city up to more problems. He did not see this as a business on every corner type of situation.

City Attorney Wells supported what City Planner Abboud stated, narrowly focus on what the City wants to have discretion since the city will be involved in every application but the state will be involved in any possible backlash. The city should narrowly focus its involvement.

Commissioner Erickson requested clarification with commercial ventures, questioning if they should keep it all in General Commercial until they see where it falls. Her other question is if they allow this type of commercial business in Rural Residential would they have to allow other types of commercial enterprises also.

City Attorney Wells stated that the commission should carefully review which districts to allow it and then allow it outright due to the nature of the CUP process. That they should limit the requirements. She further noted that the commission should consider that this is a new industry and look at each district and what they currently allow in each of those districts that is similar to this industry. She further stated that as far as allowing it in Rural Residential, the commissioners have to really consider if they want this business in that district, it is new, yes, but in many ways it is the same as any other business. It would be a good use of time to consider the challenges since it is still federally unlawful and there are many questions and concerns surrounding the legislation and regulation of the industry.

Commissioner Venuti questioned the status of the 1000 ft rule. City Planner Abboud explained that the Cannabis Advisory Commission (CAC) has discussed this issue too, especially regarding the federal requirements, and have questioned whether this rule would apply to the college. He will be checking more into that for both commissions.

There was a brief comment on extending the meeting since it was coming up on the deadline.

ERICKSON/HIGHLAND - MOVED TO EXTEND THE MEETING TO 10:15 PM

There was no discussion.

VOTE. YES. NON-OBJECTION. UNANIMOUS CONSENT.

Motion carried.

ERICKSON/HIGHLAND - MOVED TO PROHIBIT SMALL CULTIVATION IN THE BRIDGECREEK WATERSHED PROTECTION DISTRICT, RURAL RESIDENTIAL AND SMALL AND LARGE CULTIVATION IS ALLOWED AND/OR PERMITTED IN GENERAL COMMERCIAL 1 AND GC 2

Brief discussion by the commission on the fact the Rural Residential comprises 75% of Homer and they encourage certain actions in rural residential.

VOTE. YES. HIGHLAND, BRADLEY, ERICKSON, STEAD, STROOZAS

VOTE. NO. VENUTI

Motion carried.

Highland questioned corrections to line 362-365 in the draft ordinance. Staff noted that all corrections will be done prior to the next regular meeting. He then asked the commission to consider allowance in the East End Mixed Use District.

ERICKSON/ STROOZAS - LARGE CULTIVATION IS ALLOWED IN EAST END MIXED USE TO BE CONSISTANT.

There was no discussion.

VOTE. YES. STROOZAS, STEAD, ERICKSON, BRADLEY, HIGHLAND.
VOTE. NO. VENUTI.

Motion carried.

City Planner Abboud inquired about actions on retail activities in any district. He noted that the General Commercial is good but the CBD is a toss-up.

ERICKSON/ HIGHLAND - MOVED THAT RETAIL ACTIVITIES BE ALLOWED IN GENERAL COMMERCIAL 1 AND GENERAL COMMERCIAL 2 AND THE EAST END MIXED USE DISTRICTS CONSISTANT WITH CULTIVATION IN THOSE DISTRICTS.

Discussion followed on changing from having the conditional use process in these districts and the fact the commission is limited to follow the law, offer areas where people who want to do the business they want to do and keep it out of areas that people don't want to have it. The fact that this has to be allowed somewhere and currently the way it is written there is no retail allowed in the city without a CUP.

VOTE. YES. HIGHLAND, BRADLEY, ERICKSON, STEAD, VENUTI, STROOZAS.

Motion carried.

Chair Stead noted that they are past the 10:15 p.m. deadline for the meeting and questioned if there is a desire to extend the meeting time again. The commission agreed by consensus to adjourn the meeting. Staff recommended that they allow comment since several people stayed throughout the entire length of the meeting.

Chair Stead noted for the record that they will postpone discussion on the item until the next regular meeting and go straight comments of the audience.

B. Staff Report PL15-81 Towers Considerations

NEW BUSINESS

A. Staff Report PL 15-84 Marijuana Business Licenses

INFORMATIONAL MATERIALS

A. City Manager's Report from November 23, 2015 City Council Meeting

COMMENTS OF THE AUDIENCE

Members of the audience may address the Commission on any subject. (3 minute time limit)

Catriona Reynolds commented that the limit for Council financial conflict of interest is \$500. She further noted that CUP's put on Right of Way rather than the person's property have been problematic in the past.

COMMENTS OF STAFF

City Planner Abboud commented on the changes made by the Commission and that if they are going to allow this industry then they needed to pick the places to allow it, don't make the hurdles so high. If they don't want it, then ban it. He was afraid of an unending appeal of a CUP that they approve and if they went that way and what those costs to the city would do. It was a productive meeting.

Deputy City Clerk Krause noted the city code did not reflect a specific amount, just “substantial financial” for the Conflict of Interest and that it was probably outlined in their bylaws. It is always better to err to the side of caution. Very good meeting though long.

COMMISSION

Commissioner Highland had no comments.

Commissioner Bradley wished everyone Happy Holidays and reminded the commissioners to state the reasons they vote so it does not appear that they are coming out with random decisions and that they might need someone to speak at the next council meeting.

Commissioner Erickson wished everyone a Merry Christmas and Happy New Year and that it was a bit tense there for a bit. She doesn't like to make people unhappy but believes they made did their best in a tough situation

Commissioner Venuti tough meeting and commended the holdouts in the audience tonight. Commissioner Stroozas announced the tree lighting ceremony at the Chamber on Friday, December 4th with Santa and then Thursday is the Annual Raffle at the Elks Lodge at 6:00pm. He then wished everyone a Very Merry Christmas and Happy New Year.

Chair Stead echoed the sentiments wishing everyone a Merry Christmas and a very Safe New Year and he will see everyone on January 6, 2016.

ADJOURN

There being no further business to come before the Commission, the meeting adjourned at 10:35 p.m. The next regular meeting is scheduled for WEDNESDAY, JANUARY 6, 2016 at 6:30 p.m. in the City Hall Cowles Council Chambers. There is a worksession at 5:30 p.m. prior to the meeting.

Renee Krause, CMC, Deputy City Clerk

Approved: _____



December 21, 2015

Homer City Council
City of Homer
491 East Pioneer Avenue
Homer, Alaska 99603

Dear Mayor Wythe & City Council Members:

Thank you to the City of Homer for continuing its support of the nonprofit community through funds administered by the Homer Foundation. This consistent support makes a big difference in our capacity to provide a wide range of services to local residents.

For example, support from the City of Homer has helped us build our Alaska Clean Harbors certification program, where the City of Homer took the lead statewide in embracing pollution prevention measures designed to protect water quality while reducing costs; establish a large set of baseline data through our Citizens Environmental Monitoring Program which helps resource managers make better decisions; assist local citizens with well water education and testing through our Safe Drinking Water project; and through our Electronics Recycling Project, we've kept over 175,000 pounds of electronic waste out of the Homer Landfill.

Inletkeeper is now spearheading a pilot online food hub on the Kenai Peninsula. Today, we have 680 farms across the state but 95% of our food comes from Outside (ADN, Nov. 4, 2013). This presents numerous problems, including the climate impacts of food transportation, the lack of food security for Alaskans and a need to support Alaskan farmers and fishermen economically. As a result, we're now working to connect farmers and fishermen with consumers, to help grow our community and give Homer residents better access to local foods.

As we enter 2016, Inletkeeper employs eleven staff people—seven of whom reside in Homer. Since our inception in 1995, we have created numerous opportunities for meaningful employment and added over \$12 million to the local economy. Importantly, support through the grants program has a considerable multiplier effect, and we're able to leverage relatively small contributions into larger revenues we then spread throughout the community.

So, thank you. Support from the City of Homer demonstrates the Council's commitment to making Homer a world-class place to live, work and play. And thank you too for your dedicated service to our community.

Very truly yours,

Bob Shavelson
Executive Director

cc: Homer Foundation





Kachemak Nordic Ski Club supporters,

Thank you for your continued support of the club and for allowing our trails on your land. Attached you will find a copy of the liability certificate listing you as a certificate holder in the bottom left. Please note that this policy runs from November 2015 – November 2016.

We are very appreciative of your continued support of the Kachemak Nordic Ski Club. You make these trails possible! We're excited to be skiing already this year and know it's going to be an excellent year for the club.

Feel free to email us at kachemaknordicskiclub@gmail.com with questions.

Sincerely,

Jan Spurkland

KNSC President

11-23-15

Jalee Martushev
4103 Mattox Unit 1
Homer, Alaska, 99603

Donna Aderhold
Homer City Hall
491 E. Pioneer Avenue
Homer, Alaska 99603

Dear Homer Council member, Donna Aderhold

I am 15 years old, and a sophomore this year at Homer High school. I appreciate what this school has taught me so far. I went from a small Russian village school in Nikolaevsk with 70 students K through 12. In 2013, I moved to Homer and this was a huge change for me as there was a lot more students, better activities to broaden my horizons, and just a better community to live in. When I first moved here I was home schooled the first semester of my eighth grade year. I volunteered part of my time at Little Fireweed, ironically under the direction of my old kindergarten teacher I had in Nikolaevsk. At this same time my two little sisters also attended this school, and one still does today. In the time I volunteered there I had noticed that whenever they left for walks or on an outdoor exploration trip, the teachers and volunteers who were there literally had to wait for the right time and walk out into the road and make sure the traffic came to a complete stop before the children were escorted safely across.

My mother witnessed one incident where a car completely ignored the fact and she watched in horror as the car blew right past the teacher. Thankfully the teacher was fine and the students were all well away from the road until it was clear as they were always instructed to do. This made me think and it worried me. I wondered why there were no blinking lights, speedbumps, or crosswalks at all when there are three schools in approximately a four block area. There is Homer Flex, Little Fireweed, and Homer High right in a row, and not one crosswalk. The closest one is at the three way stop which is about a block from the high school, Two blocks from Little Fireweed, and about three and a half blocks from Homer Flex. This crosswalk is out of the way for any kids or pedestrians going to any of the schools or SVT even. I, personally, have heard people complain that when walking their child to school or picking them up they have to wait until there is no traffic to cross with their child or children, and worry about their child taking off or getting hit on such a busy road. It is like this every weekday in the mornings before school and after school.

Another fact, many people in our community get angry because teenagers or adults walk across the road when they can, and not at a crosswalk. Community drivers don't seem to stop and think that there are no crosswalks in front of any of these three schools! Without a cross walk that's considered jaywalking and you can be fined for it. It's hard when people need to get to a school on time and don't have a crosswalk unless they walk anywhere between one to three blocks out of the way and that's just one way, in order to cross safely and be okay through the eyes of the law. That's a problem. **A big one!** It's important for our members in our community to be safe, and to keep our kids safe.

As I started typing this paper I asked myself: "If a driver can receive a ticket for not yielding to a pedestrian at a crosswalk, then can a pedestrian be cited for not using a crosswalk to get across the street, and stop traffic in doing so"? The answer is yes! Here's why. I researched jaywalking laws

and discovered that(depending on the state), it caught jaywalking in can be a citation, a misdemeanor, an infraction or it can be as harsh as reckless endangerment if a person isn't paying attention and crosses the road and causes an accident. A civil suit could also be as well and you could face up to a year in jail and/or up to a \$10,000.00 fine. In Alaska, you could be fined a \$25.00 citation per offense and the Alaska statutes state that if no crosswalk is near you the pedestrian must yield to all vehicles and cannot be a hazard. You must also cross at a right angle to the roadway and take the shortest route. **Alaska statute AS11.41.250.** Many drivers do not stop for pedestrians; sometimes even when they're in the crosswalk! I have seen this more than once in Homer. Again, this is a problem especially for the kids who go the schools I mention before earlier.

Homer High, Little Fireweed, and Homer Flex are right in a row. **There are no crosswalks** for them. Personally, I have walked on the sidewalk on my way to get my sister at Little Fireweed and I have to wait 10 minutes or so just to walk across the street. With schools getting out around the same time every day and drivers being frustrated it's an accident waiting to happen. Someone eventually will get hurt. I hope it's not one of my sisters or myself. So why not take action before something does happen. Once in a while, you will get a person who will stop and let you cross but **there needs to be crosswalks!**

I'm asking for a crosswalk to be put in at Homer High, Little Fireweed, and Homer Flex. If only one crosswalk can be granted my opinion is that it should be placed in front of Little Fireweed for two reasons. One, I feel the littlest kids are the most important and are at the most risk of injury. Two, it is right in the middle of all three schools and closer than the three way stop to the entrance of these schools. Many people around Homer would be grateful and be happy if this request is granted that I am placing before today. Several people have complained about there not being one and it desperately needs to happen. The crosswalks would be put to great use if they are placed with a blinking light or speedbumps even, to let the traffic know that these three or four blocks are a school zone! Right now, these section of road is not marked well if at all. Please support our community in putting crosswalks in the places I mentioned. It would be comforting to know that the kids would be safer, the drivers would be better warned, and the council would be the ones backing the decision.

Sincerely,

Jalee Martushev

11/23/15

Alia Bales
1295 Mission rd
Homer, Alaska, 99603
alia.bales@g.kpbsd.org

Donna Aderhold
Homer City Council
491 E. Pioneer Avenue
Homer, Alaska 99603

Dear Ms. *Aderhold*

I am a student at Homer High School. I moved to Homer, Alaska about a year and a half ago from a suburb outside of Dallas Texas. Since moving here, I realized that the city of Homer does not have very much to offer, activity wise for younger people. Where I came from, there were shopping malls, water parks, amusement parks, rec centers, and tons of different kinds of museums and galleries, tons of parks, and places for teenagers and young adults to spend their time. Here in Homer there isn't much to do, so people wind up getting depressed and being unsafe.

There is a lot of cutting and drug abuse in Homer, Alaska, along with the whole state. Many teens and young adults in our community struggle not only depression but boredom. There are many reasons why someone can become bored. The weather often prevents people from being active and being outside. When the weather is bad young people will go to their friends' houses and smoke marijuana, and consume other harmful materials. When the weather is good (like in the summer), young adults wind up doing drugs in forests and running around town looking for trouble. Merchants do not like teenagers hanging around in their store. When people are in a stores for long enough, they get bad ideas, like shoplifting. The library is a place for reading and being quiet. The librarians do not want teenagers making noise and disrupting the peaceful, working environment. The good thing about our community is that we are very athletic. 75% of HHS student's area athletes. It should be pretty easy for us to help the boredom and drug abuse in Homer.

I propose we build a rec center. This building would provide a place for the community to use, work out and play games. This will help the boredom of the town. And it would help teens not stay at home and think of all the reasons why there life is terrible. Having a rec center would also help out the high school, and middle school. If the community had a place to do their activities, then the high school and middle school sports would not be disrupted. Building a rec center could possibly knock down an area commonly used for drugs. There is a bushy area on the left of Safeway, which could possibly be used for the building place for the center. This would benefit the community tremendously. A rec center would encourage people to get something done, and give people the opportunity to work out. At the same time take down an area abused for drugs and alcohol. I hope you will take this into consideration.

Sincerely,
Alia Bales



PUBLIC HEARING(S)

ORDINANCE(S)

CITY MANAGER'S REPORT



City of Homer

www.cityofhomer-ak.gov

Office of the City Manager

491 East Pioneer Avenue
Homer, Alaska 99603

citymanager@cityofhomer-ak.gov

(p) 907-235-8121 x2222

(f) 907-235-3148

City Manager's Report

TO: Honorable Mayor Wythe and Homer City Council
FROM: Katie Koester, City Manager
DATE: January 11, 2016
SUBJECT: City Manager's Report

It has been 5 weeks since the last Council meeting - feels like almost an eternity! I hope everyone enjoyed the respite and the holidays. There promises to be plenty to keep us busy in 2016.

Storm Drain Failure on Bunnell Avenue

On Tuesday, a hole opened up in the Bunnell Street roadway, south of Main Street. The "sink hole" was caused by a deteriorated 36" storm drain which allowed soil to wash into the drain - undermining the pavement. Public Works responded; excavated to expose the drain, put a patch on the hole in the side of the storm drain, and backfilled the hole. Pavement will be replaced in the Spring. The storm drain was installed by the State in the early 80's. This storm drain, as well as the storm drain in Heath Street (installed during the same time frame), will need some work. These two storm drains serve the Central Business District. Public Works will be working with ADOT to determine who is responsible for rehabilitation. Public Works will be asking the Council for authorization to proceed with the design of a fix for the portion that the City is responsible for at the second meeting in January using HART funds.

Council Open House at Library

A patron at the Homer Public Library suggested the Council do a once a month 'open house' with the public at the library. It could be a good way to increase dialogue with the public and reach out to the community in a new way.

The Friends of the Library are willing to advertise it through their usual channels (flyers, newsletter, community calendar, radio). If the program is successful and at a regular time, the community will come to expect the event and advertising won't be as much of an issue.

It is hard to predict what would be the best time for turn out, however the Library Director suggested lunch time. People are out and about then, and people who work could stop in on their lunch hour. One option would be the first Council Monday of the month - which would give people an alternative to an evening meeting to visit with you. A noon meeting could be held in the study room and we could serve tea/coffee. If one councilmember a month volunteers, each member will have to commit to two lunch meetings a year (or less).

If Council is interested, I suggest you pick a time and day and give it a try for one month each. Then we can revisit if it is successful. I can circulate a signup sheet via email. I propose starting next month, February 8 at noon.

Seafarer's Memorial Camping

The Seafarer's Memorial parking lot has been occupied this fall/winter by a dozen long term campers. Some of the trailers are in such a bad state of repair they had to be towed in. The site has been problematic; HPD has arrested several of the campers for various misdemeanors. HCC 19.08.030(d) allows people to camp in the Seafarer's Memorial parking lot when all City campgrounds are closed (April 1-October 30). The same section allows the City Manager to open a campground at any time. I have issued the attached notice to open the Pier One campground. On December 15th campers were served notice that they needed to move their camper to the Pier One Theatre lot or elsewhere. To date, none of them have moved. The next step is for HPD to enforce the issue with fines and impounds. During the process, as always, HPD will refer individuals in need of any available services.

Hickerson Cemetery

A couple of Borough residents have brought concerns with the impact to area groundwater and clearing of trees associated with the expansion of Hickerson Cemetery to the attention of city staff and Council. I have offered to hold a neighborhood meeting so residents have an opportunity to ask questions and air their concerns which I am hoping will be a good starting place to work with the neighborhood.

The Hickerson Cemetery expansion project has been in the works since 2010 when the land was purchased adjacent to the existing cemetery. The 2012 budget authorized design, and this year Council authorized a phased development of the first few hundred plots. Though if winter conditions allow, Public Works could do some site preparation of the land this winter. The project will not be bid until the next construction season.

Homer cemeteries average 12 burials a year, and according to the Homer Funeral Home, only about half of those choose to be embalmed (which involves chemicals that are of a concern to area residents). Using arsenic in the embalming process was discontinued in the early 1900s. The existing Hickerson Cemetery was developed in 1960. City of Homer Public Works checked with the State (DEC drinking water and solid waste management) to make sure all the proper rules are followed. There are no State regulations regarding the creation or expansion of cemeteries as it relates to zoning/groundwater concerns. The KPB has established no zoning in the area of the proposed cemetery and does not regulate the creation or expansion of cemeteries. According to the Public Works Director and City Engineer, the hydrology of the area is conducive for minimizing or eliminating the potential for metals (from deceased fillings, watches, etc.) or embalming fluid from entering groundwater and moving off site.

I know the Council has both an interest in being a good neighbor and providing area community members a place to bury their loved ones. If the community members feel

strongly one way or another, I encourage them to let the City know. I will keep the Council abreast of how the project progresses.

KPEDD Industry Forum

Kenai Peninsula Economic Development District will be holding their annual Industry Outlook Forum this January 28-29 (draft agenda attached). This is open to the public, free, and a great opportunity to network with industry professionals and other business and public entities on the Peninsula and around the state. Register here: <https://www.eventbrite.com/e/industry-outlook-forum-2016-tickets-19973176308>

City Manager's Office Staffing

As you know, Assistant City Manager Patrick Lawrence left the City of Homer at the end of 2015. I have struggled with how to fill his position. There is plenty of justification for an Assistant City Manager position given the work load and supervisory responsibilities in the City Manager's office. Nevertheless, I also feel like it is difficult in these lean budget times to justify funding the position at the level that is needed to attract qualified candidates. I have decided to advertise the position as a Special Projects/Communications Coordinator. This person will be in charge of the CIP, website and social media, and staffing the Economic Development Advisory Commission, among other things. Given the projects the City has on its plate, the position will also have a renewed emphasis on grant writing. However, I will retain many of the afterhours and broader community relations functions as this will not be a salaried position. I am confident we will receive excellent candidates and the changes in the job description will benefit the City. However, I am concerned about capacity in the City Manager's office with these changes and the administrative assistant position moving to a part time status. I will ask for help if I need it at midyear, but am looking forward to solidifying my team for 2016 and getting our feet under us. Please direct any interested candidates for the Special Projects/Communications position to the City website.

New Website

I have mentioned that the City is going to have a new website design in a couple of City Manager reports, however over the holidays we took the plunge and transitioned to a more mobile friendly template with greater capacity. Holly Brennan at the Library deserves special recognition for taking on the immense technical details of this project. The new site has inspired a renewed interest in the website from City departments, which is a good thing as we strive to be more communicative with the public. There are still a few bugs to work out linking the old site to the new design, so please let my office know if you see something that needs tweaking or does not work quite right as you navigate around.

Enc.

Notice of Opening Fishing Hole Campground
Industry Outlook Forum Agenda
Grant Support for Homer Kachemak Bay Rotary Club
Homer Public Library Advertised in Lonely Planet



City of Homer

www.cityofhomer-ak.gov

Office of the City Manager

491 East Pioneer Avenue
Homer, Alaska 99603

citymanager@cityofhomer-ak.gov

(p) 907-235-8121 x2222

(f) 907-235-3148

NOTICE

Due to a demand for camping outside of the traditional camping season, effective January 1, 2016, I am opening camp spaces 1 to 16 of the Fishing Hole Campground next to Pier One Theater on the Homer Spit until further notice. City campgrounds are closed by ordinance from September 30th to April 30th. However, according to Homer City Code 19.08.030d, they can be opened at any other time by order of the city manager.

City of Homer campground rules and fee schedule applies and will be enforced.

Katie Koester
City Manager



*Leadership to enhance, foster
and promote economic development*

INDUSTRY OUTLOOK FORUM

HOSTED BY

*Kenai Peninsula Economic Development District
And Supported By*

*City of Kenai, City of Soldotna,
And Chambers of Commerce of Kenai, Soldotna, Seward
and Homer*

Thursday, January 28th, 2016

8:15	Registration and Continental Breakfast
9:00	<p>Welcome Pledge of Allegiance Self-Introduction</p> <p>Moderator: Tim Dillon <i>Kenai Peninsula Economic Development District Board of Directors City Manager of Seldovia</i></p>
9:15	<p>Workforce Development and Economic Overview</p> <p>Alyssa (Shanks) Rodrigues (Confirmed) <i>Economist III, Alaska Department of Labor and Workforce Development</i></p>
9:45	<p>Barbara Sheinberg (Confirmed) <i>Sheinberg Associates, Situation and Prospects Update</i></p>
10:15	Networking Break-Door Prize Drawing

10:30	Community Economic Outlook Mayor Mike Navarre – <i>Kenai Peninsula Borough</i> (Invited) Mayor Pat Porter – <i>City of Kenai</i> (Invited) Mayor Pete Sprague - <i>City of Soldotna</i> (Invited) Mayor Bill Overway - <i>City of Kachemak</i> (Invited) Mayor Dean Lent – <i>City of Seldovia</i> (Invited) Mayor Jean Bardarson - <i>City of Seward</i> (Invited) Mayor Beth Wythe - <i>City of Homer</i> (Invited)
12:00	Lunch Keynote Speaker: State Revenue Update To Be Determined <i>State of Alaska</i> **To be broadcast**
1:00	Melissa Houston, UA Center for Economic Development (Invited) <i>Associate Director for Strategy</i>
2:00	Networking Break- Door Prize Drawing
2:15	Bruce Webb, Vice President (Invited) <i>Furie Alaska</i>
2:35	John L. Hendrix, General Manager (Invited) <i>Apache Corporation</i>
2:55	Benjamin Johnson, CEO (Invited) <i>Blue Crest Energy</i>
3:15	Dave Wilkins, Senior Vice President (Confirmed) <i>Hilcorp Alaska LLC</i>
3:35	Networking Break-Door Prize Drawing
4:00	Frank Richards, VP Engineering and Program Management (Confirmed) <i>Alaska Gasline Development Corporation</i>
4:30	Reception (No Host Bar)
5:30	Congressional Update Video Presentation from: Congressman Don Young (Invited) Via DVD Senator Lisa Murkowski (Invited) Via DVD Senator Dan Sullivan (Invited) Via DVD
6:15	Keynote Speaker: <i>Dinner at the old Carr's mall</i>
6:40	Ross Sorensen, Contracting Lead (Invited) <i>Alaska LNG Project</i>



*Leadership to enhance, foster
and promote economic development*

INDUSTRY OUTLOOK FORUM

HOSTED BY

Kenai Peninsula Economic Development District

SUPPORTED BY

City of Kenai, City of Soldotna,

*And Chambers of Commerce of Kenai, Soldotna, Seward
and Homer*

Friday, January 29th, 2016

8:15	Registration and Continental Breakfast
9:00	<p>Welcome</p> <p>Moderator: Tim Dillon <i>Kenai Peninsula Economic Development District Board of Directors City Manager of Seldovia</i></p>
9:15	<p>Bruce Anders, Vice President (Invited) <i>CIRI Alaska Native Corporation</i></p>
9:45	<p>Gabriel Kompkoff, CEO (Invited) <i>Chugach Commercial Holdings</i></p>
10:15	Networking - Break
10:30	<p>Rick Davis, Chief Executive Officer (Confirmed) <i>Central Peninsula Hospital</i></p>

10:50	Monica Adams, Chief Executive Officer (Invited) <i>Peninsula Community Health Services</i>
11:10	Networking - Break
11:25	Gary J. Turner, Director & CEO (Invited) <i>Kenai Peninsula College</i>
11:45	Ben Eveland, Director (Invited) <i>AVTEC Institute of Technology</i>
12:05	Lunch Keynote Speaker: To Be Determined <i>State of Alaska</i> **To be broadcast**
12:45	Mining Update Dan Graham, Project Manager (Confirmed) <i>Pacrim Coal, LP</i>
1:15	Mike Heatwole, VP of Public Affairs (Confirmed) <i>The Pebble Partnership</i>
1:45	Kurt Parkan, External Affairs Manager (Confirmed) <i>Donlin Gold</i>
2:15	Closing Remarks



City of Homer

www.cityofhomer-ak.gov

491 East Pioneer Avenue
Homer, Alaska 99603

(p) 907-235-8121

(f) 907-235-3140

Homer Foundation
3733 Bean Walters Lane #4
Homer, AK 99603

December 30, 2015

Dear Homer Foundation,

The City of Homer supports a grant application by the Homer Kachemak Bay Rotary Club in the amount of \$5,000 to build a picnic shelter. The shelter supports the Kachemak Bay Water Trail trailhead, and will be on city parkland near the Nick Dudiak Fishing Lagoon. The City envisions the shelter will be very popular with a diverse group of day users due to its location near fishing, the trailhead, and its distance from the road noise and wind of Homer Spit Road.

The City of Homer supported this project with \$5,000 in capital project funds during the 2015 budget cycle. With those funds, the City hoped that Rotary could leverage more public and private funding to complete the project. Rotary's application to the Homer Foundation has the support of the City as they move forward on this new asset to the community.

Sincerely,

Katie Koester
City manager

Drinking & Nightlife

The bumper sticker says it all: 'Homer, Alaska: A quaint drinking village with a fishing problem.'

Kharacters BAR
(Map p246; Pioneer Ave) Pure Alaskan, this smoke-filled, intimate bar has a delicious, terous cro

Salty Dawg
(Map p250; storied bar Dawg isn't cavernous pool table start in ea

Down East Saloon BAR
(Map p250; 3125 E End Rd) This spacious bar is where locals head to listen to live music. The view is killer, but you'll likely be paying more attention to whichever Homer talent is on stage and the sexy hippies.

The Alibi BAR
(Map p246; www.alibihomer.com; 453 E Pioneer Ave; ☉4pm-4am) Catering to a younger crowd, the Alibi has DJs, karaoke and occasional dance parties. The large picture windows reveal the bay and locals say the food isn't bad.

Homer Brewing Company BREWERY
(Map p246; www.homerbrew.com; 1411 Lakeshore Dr; ☉noon-7pm Mon-Sat, to 6pm Sun) This tasting room has picnic tables and fresh Jakalof Bay oysters Friday and Saturday. Try the broken birch bitter ale and then grab a growler to go.

Bear Creek Winery WINE BAR
(Map p250; www.bearcreekwinery.com; Bear Creek Dr; ☉10am-6pm) Wineries are scarcer than vineyards in Alaska, but this impressive family-run operation bottles some fine berry-based wines. Tastings are \$5 (credited to your purchase), and they do tours at 11am Monday, Wednesday and Friday.

Entertainment

Pier One Theatre THEATER
(Map p250; ☎907-235-7333; www.pieronetheatre.org; Homer Spit Rd) Live drama and comedy are performed in a 'come-as-you-are' warehouse next to the Fishing Hole on the Spit. Shows start at 8:15pm Friday and Saturday, and 7:30pm Sunday during summer.

Shopping

Chain Reaction Sports SPORTS
(Map p246; 5 Lake St; ☉8am-7pm Mon-Fri, to 5pm Sat & Sun) This outfitter sells camping, hunting and fishing supplies.

Information

INTERNET

Homer Public Library (500 Hazel Ave; ☉10am-6pm Mon, Wed, Fri & Sat, to 8pm Tue & Thu; ☎☎) Homer's excellent library is arty and airy, with a decidedly Homer-esque selection of magazines. Internet access is free, and they have a great kids section for rainy days.

LAUNDRY

East End Laundry (Mile 2.9, E End Rd; ☉10am-8pm Mon-Sat) Convenient to Seaside Farm.
Sportsman's Supply & Rental (1114 Freight Dock Rd; ☉6am-midnight) Offers showers (\$7) and laundry right on the Spit.
Washboard Laundromat (\$6) The showers come with towels and last as long as you want.

MEDICAL SERVICES

Homer Medical Clinic (☎907-235-8586; 4136 Bartlett St) Next door to South Peninsula Hospital; for walk-in service.
South Peninsula Hospital (☎866-235-0369; Bartlett St) North of the Pratt Museum.

MONEY

Wells Fargo (88 Sterling Hwy) ATM.

POST

Post Office (Map p246; 3658 Heath St)

TOURIST INFORMATION

Halibut Derby Office (Map p250; ☎907-235-7740; www.homerhalibutderby.com; Homer Spit Rd; ☉5:30am-8am & 3-7pm) Has a few pamphlets and is the official weigh-in station for the Homer Halibut Derby.
Homer Visitor Center & Chamber of Commerce (Map p246; ☎907-235-7740; www.homer.alaska.org; 201 Sterling Hwy; ☉9am-6pm Mon-Fri, 10am-5pm Sat & Sun) Has countless brochures and a funky mosaic on the floor. It's operated by the chamber of commerce, however, and only provides info on members.

Getting There & Around

AIR

Ravn Alaska (p219) provides daily flights between Homer and Anchorage from Homer's airport, 1.7 miles east of town on Kachemak Dr. The advance-purchase fare runs at about \$140 one-way, or \$250 for the round-trip. **Smokey Bay Air** (☎907-235-1511; www.smokeybayair.



City of Homer

www.cityofhomer-ak.gov

Office of the City Clerk

491 East Pioneer Avenue
Homer, Alaska 99603

clerk@cityofhomer-ak.gov

(p) 907-235-3130

(f) 907-235-3143

Memorandum

TO: MAYOR AND CITY COUNCIL

FROM: MELISSA JACOBSEN, CMC, DEPUTY CITY CLERK

DATE: DECEMBER 31, 2015

SUBJECT: BID REPORT

ITB CITY HALL, PARKS, AND CEMETERIES MAINTENANCE - Sealed Bids for CITY HALL, PARKS, and CEMETERIES MAINTENANCE will be received by the Office of the City Clerk, 491 E. Pioneer Avenue, Homer, Alaska 99603 until 2:00 p.m., Thursday, January 21, 2016, at which time they will be publicly opened and read. Bids received after the time fixed for receipt of the Bid shall not be considered. All bidders must submit a City of Homer Plan Holders Registration form to be on the Plan Holders List and to be considered responsive. Plan holder registration forms, and Plans and Specifications are available on line <http://www.cityofhomer-ak.gov/rfps>

CITY ATTORNEY REPORT

COMMITTEE REPORTS

PENDING BUSINESS

ORDINANCE REFERENCE SHEET
2015 ORDINANCE
ORDINANCE 15-43

An Ordinance of the City Council of Homer, Alaska, Repealing Homer City Code Chapter 3.12, Permanent Fund, Placing the Funds in a Self-Managed Brokerage and Disbanding the Permanent Fund Committee.

Sponsor: City Clerk/Permanent Fund Committee

1. Council Regular Meeting November 23, 2015 Introduction
 - a. Memorandum 15-190 from Permanent Fund Committee as backup
2. Council Regular Meeting December 7, 2015 Public Hearing and Second Reading
 - a. Memorandum 15-190 from Permanent Fund Committee as backup
3. Council Regular Meeting January 11, 2016 Second Reading (postponed from December 7)
 - a. Substitute Ordinance 15-43(S)
 - b. Memorandum 15-190 from Permanent Fund Committee as backup

1 **CITY OF HOMER**
2 **HOMER, ALASKA**

3 City Clerk/
4 Permanent Fund Committee

5 **ORDINANCE 15-43**
6

7 AN ORDINANCE OF THE CITY COUNCIL OF HOMER, ALASKA,
8 REPEALING HOMER CITY CODE CHAPTER 3.12, PERMANENT
9 FUND, PLACING THE FUNDS IN A SELF-MANAGED BROKERAGE
10 AND DISBANDING THE PERMANENT FUND COMMITTEE.
11

12 WHEREAS, The Homer Permanent Fund was established by Ordinance 05-14(S) for the
13 purpose of receiving monies from the distribution of the Exxon Valdez Oil Spill settlement and
14 other windfall funds, and serving as an endowment whose income would be used to support
15 City government, and whose principal could be loaned to support City capital projects; and
16

17 WHEREAS, The amount that the City received from the distribution of the Exxon Valdez
18 Oil Spill settlement and other windfall funds was substantially less than anticipated at the
19 time the Homer Permanent Fund was established; and
20

21 WHEREAS, In the current investment environment, an excessive amount of the Homer
22 Permanent Fund income is consumed by the cost of the fund's administration; and
23

24 WHEREAS, The Homer Permanent Fund could be managed with less service fees and
25 match the S&P 500 market returns by placing the Fund in a self-managed brokerage fund; and
26

27 WHEREAS, It is appropriate to repeal the Homer City Code provisions regarding the
28 Homer Permanent Fund and to disband the Permanent Fund Committee.
29

30 NOW, THEREFORE, THE CITY OF HOMER ORDAINS:
31

32 Section 1. Homer City Code Chapter 3.12, Permanent Fund is repealed.
33

34 Section 2. The City Council hereby disbands the Permanent Fund Committee that was
35 created by Ordinance 05-14(S).
36

37 Section 3. Section 1 of this Ordinance is of a permanent and general character and
38 shall be included in the City Code. Section 2 of this Ordinance is temporary in nature and
39 shall not be codified.
40

41 ENACTED BY THE CITY COUNCIL OF HOMER, ALASKA, this ____ day of _____
42 2015.

[**Underlined added.** Deleted language stricken through.]

43
44
45
46
47
48
49
50
51
52
53
54
55
56
57
58
59
60
61
62
63
64
65
66
67
68
69
70
71

CITY OF HOMER

MARY E. WYTHE, MAYOR

ATTEST:

JO JOHNSON, MMC, CITY CLERK

AYES:

NOES:

ABSTAIN:

ABSENT:

First Reading:

Public Hearing:

Second Reading:

Effective Date:

Reviewed and approved as to form:

Mary K. Koester, City Manager

Thomas F. Klinkner, City Attorney

Date: _____

Date: _____

1 **CITY OF HOMER**
2 **HOMER, ALASKA**

3 City Clerk/
4 Permanent Fund Committee

5 **ORDINANCE 15-43(S)**

6
7 AN ORDINANCE OF THE CITY COUNCIL OF HOMER, ALASKA,
8 AMENDING HOMER CITY CODE 3.10.130, GOVERNANCE OF
9 HOMER PERMANENT FUND ASSETS, REGARDING THE
10 MANAGEMENT OF INVESTMENTS OF THE HOMER PERMANENT
11 FUND.

12
13 WHEREAS, The Homer Permanent Fund was established by Ordinance 05-14(S) for the
14 purpose of receiving monies from the distribution of the Exxon Valdez Oil Spill settlement and
15 other windfall funds, and serving as an endowment whose income would be used to support
16 City government, and whose principal could be loaned to support City capital projects; and

17
18 WHEREAS, The amount that the City received from the distribution of the Exxon Valdez
19 Oil Spill settlement and other windfall funds was substantially less than anticipated at the
20 time the Homer Permanent Fund was established; and

21
22 WHEREAS, In the current investment environment, an excessive amount of the Homer
23 Permanent Fund income is consumed by the cost of the fund's administration; and

24
25 WHEREAS, The Homer Permanent Fund could be managed with less service fees and
26 match the S&P 500 market returns by placing the Fund in a self-managed brokerage fund; and

27
28 WHEREAS, It is appropriate to transfer management of the Permanent Fund to the
29 Finance Department and to disband the Permanent Fund Committee.

30
31 NOW, THEREFORE, THE CITY OF HOMER ORDAINS:

32
33 Section 1. Homer City Code 3.10.130, Governance of Homer permanent fund assets, is
34 amended to read as follows:

35
36 3.10.130 Governance of Homer permanent fund assets.

37 a. In investing and managing the monies of the permanent fund established pursuant
38 to Chapter 3.12 HCC, the persons having responsibility for making decisions shall exercise the
39 judgment and care under the circumstances then prevailing which an institutional investor of
40 ordinary prudence, discretion, and intelligence exercises in the management of large
41 investments entrusted to it, not in regard to speculation, but in regard to the long-term

42 investment of funds considering the probable safety of capital as well as probable income, in
43 accordance with the stated objectives of the permanent fund.

44 b. In order to ensure sound investment strategy, the City Council will take action in the
45 following manner:

46 1. The City Council shall establish written investment policies by ~~formal~~
47 resolution which shall be adhered to without exception;

48 2. The City Council shall review the investment policies of the permanent fund
49 at least once each year during the first quarter and shall, by ~~formal~~-resolution, re-
50 adopt or modify said policies;

51 3. The City Council shall establish, by ~~formal~~-resolution, a plan for the
52 allocation of investment assets each year that provides for the following:

53 a. That earnings available for annual appropriation and distribution
54 shall be confined to the interest, dividends or coupon discounts derived from
55 the investments of the fund. Realized or unrealized gains to the portfolio value
56 are not considered earnings.

57 b. The portfolio of **the** growth sub-fund will be invested primarily in
58 equities, and is exempt from HCC 3.10.040.

59 c. The portfolio of the income sub-fund will be invested primarily in
60 bonds and the other fixed rate securities authorized by HCC 3.10.040.

61 d. The income sub-fund may be used as a revolving loan **fund** for
62 various City capital projects as provided in Chapter 3.12 HCC.

63 e. **That states** ~~Sets forth~~ portfolio duration, and ~~which establishes~~
64 performance benchmarks, and ~~which estimates the~~ **estimated** percentage or
65 amount of that year's ~~annual~~-earnings that would be necessary to retain to
66 inflation-proof the fund principal;

67 4. ~~The City Council shall establish a Permanent Fund Investment Committee~~
68 ~~consisting of the Finance Director, the City Clerk, two members of the City Council,~~
69 ~~and two members of the community at large. The term of each appointment shall be~~
70 ~~two years, with initial terms of the City Council members and members at large~~
71 ~~staggered so that half of the terms will expire each year. The Committee shall be~~
72 ~~appointed by the Mayor and confirmed by the City Council. The appointment of any~~
73 ~~City official will automatically terminate on the date when the person no longer holds~~
74 ~~such City office. Any City Council member or member at large may be removed from~~
75 ~~the Committee at any time by the City Council;~~

76 5. ~~The Committee shall meet at least quarterly to provide direction as required~~
77 ~~for maintenance of the fund. The Committee shall provide regular reports of its~~
78 ~~activity to the City Council;~~

79 **46.** The City administration shall maintain on file within the offices of the
80 Finance Department monthly reports which indicate transactions affecting the
81 investment account, to include, at a minimum, transfers of cash into and out of the
82 account, and interest or dividends received by the account;

83 **57.** The City administration shall order an objective performance evaluation of
84 the investment program every year;

85 **68.** The City administration shall retain one or more bank custodians to hold all
86 investment cash and fixed income securities of the permanent fund and require that
87 the custodians shall render monthly reports to the administration regarding assets
88 held at both book and market values, and individual transactions which have taken
89 place, that the banks shall have adequate fidelity insurance, and that written
90 contracts be entered into between the City and the custodian banks;

91 ~~9. The City, with the approval of the City Council, shall retain one or more
92 professional investment managers to design portfolios and invest funds in accordance
93 with the written investment policies adopted by the City Council. The investment
94 managers shall be registered financial advisers with both the United States Securities
95 and Exchange Commission and the State of Alaska, unless otherwise exempt from
96 registration, and the investment managers shall agree to serve as a fiduciary to the
97 City. Each investment manager shall carry professional liability insurance in an
98 amount satisfactory to the City, and the terms of the investment relationship shall be
99 memorialized in a written contract entered into between the City and the respective
100 investment advisers.~~

101
102 Section 2. The City Council hereby disbands the Permanent Fund Committee that was
103 created by Ordinance 05-14(S).

104
105 Section 3. Section 1 of this Ordinance is of a permanent and general character and
106 shall be included in the City Code. Section 2 of this Ordinance is temporary in nature and
107 shall not be codified.

108 ENACTED BY THE CITY COUNCIL OF THE CITY OF HOMER, ALASKA, this _____ day of
109 _____ 2016.

110
111 CITY OF HOMER

112
113
114 _____
115 MARY E. WYTHER, MAYOR

116
117 ATTEST:

118
119
120 _____
121 JO JOHNSON, MMC, CITY CLERK

124 AYES:
125 NOES:
126 ABSTAIN:
127 ABSENT:
128
129
130 First Reading:
131 Public Reading:
132 Second Reading:
133 Effective Date:
134
135
136 Reviewed and approved as to form:
137
138
139 _____
140 Mary K. Koester, City Manager
141
142 Date: _____

Thomas F. Klinkner, City Attorney

Date: _____



City of Homer

www.cityofhomer-ak.gov

Office of the City Clerk

491 East Pioneer Avenue
Homer, Alaska 99603

clerk@cityofhomer-ak.gov

(p) 907-235-3130

(f) 907-235-3143

Memorandum 15-190

TO: MAYOR WYTHER AND HOMER CITY COUNCIL

FROM: PERMANENT FUND COMMITTEE

THRU: JO JOHNSON, MMC, CITY CLERK

DATE: NOVEMBER 17, 2015

SUBJECT: PLACING THE PERMANENT FUND IN A SELF-MANAGED BROKERAGE AND DISBANDING THE PERMANENT FUND COMMITTEE.

The Permanent Fund was established in 2006 with the intent of the City receiving a \$10M *Exxon Valdez* settlement. Other “wind-fall” monies that the City might receive were to be deposited in the Permanent Fund. The Fund was to be invested in such a manner as to provide annual appropriation to non-profit organizations from the interest, dividends, or coupon discounts derived from the investments of the fund.

Contrary to expectations, the City instead received a \$1.1M *Exxon Valdez* settlement in 2010. A Request for Proposals was issued to solicit a qualified firm to invest the Permanent Fund in accordance with the investment procedures defined by ordinance. U.S. Bank was selected to actively manage the investment portfolio and has done so since 2010.

Returns on the Permanent Fund have been minimal due to a slow-down in the U.S. economy, an incredibly strong dollar, and a fall in energy prices with little inflation. This has affected corporate earnings, subduing markets in most of North America. Overseas there is an acceleration of growth in Japan and throughout Europe. They are buying their own safe investments making everyone else buy riskier investments. This results in inflated markets and recovering economies since corporate earnings are improving. The biggest concern for long term global growth is a lack of inflation; there is 2% inflation throughout the world.

An overview of the City’s Permanent Fund:

Fixed Income is 92% of the account; 8% is cash. Period ending March 31, 2015 the fund was up .64%. One year at 1.42% gross; three years at 1.67% gross. The fund is currently invested with principal protection first and foremost. There are no risks taken and not a lot being returned.

Growth Income is 88% of the account; 4% is cash; 4% is real estate; 4% is commodities. Period ending March 31, 2015 the total portfolio net of fees is 10.75%; for the last three years the average is 9.60% per year. For the last three years total equity is at 12.10%; domestic equity is 15.49%. The S&P 500 was up 16.11%.

For the period ending March 31, 2015 returns on the Permanent Fund were below the S&P 500.

The Permanent Fund Committee discussed the possibility of issuing another RFP for investment services, but realized bank fees are standard for the services offered. Bank fees in comparison to returns are high and the investment policies are so stringent that no broker could make money on the small quantity of money we have to invest.

The Permanent Fund Committee recommends rescinding the investment language and bringing the money home to manage. The Permanent Fund would be retained by the City and the Finance Department would arrange for management of the money as other like funds are managed. Bank fees would be significantly reduced. Additionally, the committee recommends that the Permanent Fund Committee be disbanded.

Recommendation: Introduce Ordinance 15-43 to repeal HCC 3.12, Permanent Fund, and place the funds in a self-managed brokerage and disband the Permanent Fund Committee.

**CITY OF HOMER
HOMER, ALASKA**

Mayor

RESOLUTION 15-109

A RESOLUTION OF THE HOMER CITY COUNCIL TO SUPPORT THE
REPAIR AND REOPENING OF ROCKY RIVER STATE OF ALASKA
ROAD EASEMENT TO THE GULF OF ALASKA.

WHEREAS, The City of Homer desires new economic opportunities and access to
remote State and Federal lands; and

WHEREAS, Repair of the State of Alaska Rocky River Road easement can provide that
opportunity and access; and

WHEREAS, The Rocky River Road repair would grant access to remote commercial
fishing grounds, adding access to Picnic Harbor to offload fish for transportation to Jakolof
Bay; and

WHEREAS, Repaired road access would stimulate existing businesses and livelihood
for lower Kenai Peninsula; and

WHEREAS, The repaired road will provide all walks of life easier and more affordable
access to State and Federal wilderness parks through access via 17B easements to Port Dick;
and

WHEREAS, Repaired road access would stimulate recreational guide opportunities and
recreational use by all citizens of the State of Alaska; and

WHEREAS, The repair of the road will stimulate the social well-being and lead to a
healthier more robust and vibrant lifestyle of those who live in this remote region of Alaska;
and

WHEREAS, The road was washed out by disastrous weather events; and

WHEREAS, The Alaska National Guard has the resources to repair this State of Alaska
easement without additional funds from the State of Alaska.

NOW, THEREFORE, BE IT RESOLVED that the City Council of Homer, Alaska, is in
support of the repair and reopening of Rocky River State of Alaska Road Easement to the Gulf
of Alaska.

43 PASSED AND ADOPTED by the Homer City Council this 7th day of December, 2015.

44

45

CITY OF HOMER

46

47

48

49

MARY E. WYTHE, MAYOR

50

51 ATTEST:

52

53

54

55 JO JOHNSON, MMC, CITY CLERK

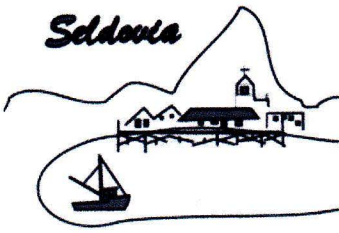

Seldovia Chamber of Commerce

Drawer F
Seldovia AK 99663
907-234-7612
Portal Websites: www.seldovia.com
www.seldoviachamber.org

2015-2016 Officers
Tamara Von Gemmingen, President
Roberta Collier, Vice-Pres.
Darlene Crawford, Sec -Treas.
Board of Directors:
Stephanie Blanchard, Angela
Campbell, Paulie Carluccio, Jenny
Chissus, Crystal Collier, and Suzie
Stranik

Resolution 2015 - 1

To repair and reopen Rocky River State of Alaska road easement to the Gulf of Alaska October 1, 2015

Whereas the communities of the Lower Cook Inlet desire new Economic opportunities
and access to remote State and Federal park lands;

Whereas repair of the State of Alaska Rocky River road easement can provide that opportunity and access;

Whereas the Rocky River road repair would grant access to remote commercial fishing grounds, adding
access to Picnic Harbor to offload fish for transport to Jakolof Bay;

Whereas repaired road access would stimulate commercial fishing support businesses on the
East side of the Kenai Peninsula;

Whereas repaired road access would stimulate existing businesses and livelihoods for lower Kenai Peninsula;

Whereas the repaired road will provide all walks of life easier and more affordable access to State and Federal
wilderness parks through access via 17B easements to Port Dick;

Whereas repaired road access would stimulate recreational guide opportunities, and recreational use by all
citizens of the State of Alaska;

Whereas the repair of the road will stimulate the social well-being and lead to a healthier more robust and
vibrant Lifestyle of those who live in this remote region of Alaska;

Whereas the road was washed out by disastrous weather events; and

Whereas the Alaska National Guard has the disaster resources to repair this State of Alaska
easement without additional funds from the State of Alaska; now, therefore, be it

Resolved, that the Seldovia Chamber of Commerce:

1. urges the Governor of the State of Alaska to order the Alaska National Guard Engineering Battalion to
repair the weather disaster damaged Rocky River Road
2. urges the Governor to direct the Alaska National Guard to use their training resource funds for the
repair

Tamara Von Gemmingen, President

11/5/15
Date

Introduced by: Bagley
Date: 10/27/15
Action: Tabled
Vote: 9 Yes, 0 No, 0 Absent

**KENAI PENINSULA BOROUGH
RESOLUTION 2015-047**

**A RESOLUTION REQUESTING GOVERNOR WALKER TO ASK THE ALASKA
NATIONAL GUARD ENGINEERING BATTALION TO REPAIR AND REOPEN
ROCKY RIVER ROAD EASEMENT FROM KACHEMAK BAY TO THE GULF OF
ALASKA**

WHEREAS, Rocky River Road is washed out in several places and is now virtually impassable due to a severe weather event in the Fall of 2012; and

WHEREAS, when repaired, Rocky River Road extends from the head of Jackolof Bay south towards Windy Bay; and

WHEREAS, the State of Alaska Rocky River road easement repair can provide new economic opportunities to the communities of the Lower Cook Inlet, and establish access to remote State and Federal park lands; and

WHEREAS, repair of the road will stimulate the social well-being of those of us who live in this remote region of Alaska, and provide all walks of life easier and more affordable access to State and Federal wilderness parks through access via 17B easements to Port Dick; and

WHEREAS, when repaired, the Rocky River Road would provide direct road access to remote commercial fishing grounds to Picnic Harbor where fish can be off loaded and trucked to Jakalof Bay; and

WHEREAS, repair of Rocky River Road would stimulate existing businesses and livelihoods including commercial fishing support businesses and recreational guide opportunities; and

WHEREAS, repairing this road would be a good training project for the Alaska National Guard without using additional funds from the State of Alaska; and

WHEREAS, repair of the Rocky River road will lead to a healthier more robust and vibrant lifestyle for remote communities of our Lower Cook Inlet region on the southern tip of the Kenai Peninsula;

**NOW, THEREFORE, BE IT RESOLVED BY THE ASSEMBLY OF THE KENAI
PENINSULA BOROUGH:**

SECTION 1. That the Kenai Peninsula Borough Assembly respectfully requests that Governor Walker ask the Alaska National Guard Engineering Battalion to repair the weather disaster damaged Rocky River Road as a training project.

SECTION 2. That a copy of this resolution be sent to Governor Walker.

SECTION 3. That this resolution takes effect immediately upon its adoption.

**ADOPTED BY THE ASSEMBLY OF THE KENAI PENINSULA BOROUGH THIS *
DAY OF * 2015**

Blaine Gilman, Assembly President

ATTEST:

Johni Blankenship, MMC, Borough Clerk

10/27/15 Vote on motion to table:

Yes: Bagley, Cooper, Dunne, Holmdahl, Johnson, McClure, Ogle, Welles, Gilman

No: None

Absent: None

City of Seldovia

Resolution 16-05

A RESOLUTION OF THE CITY COUNCIL OF THE CITY OF SELDOVIA, ALASKA TO SUPPORT THE REPAIR AND REOPENING OF ROCKY RIVER STATE OF ALASKA ROAD EASEMENT TO THE GULF OF ALASKA

WHEREAS, the City of Seldovia desires new economic opportunities and access to remote State and Federal lands,

WHEREAS, repair of the State of Alaska Rocky River Road easement can provide that opportunity and access,

WHEREAS, the Rocky River Road repair would grant access to remote commercial fishing grounds, adding access to Picnic Harbor to offload fish for transport to Jakolof Bay,

WHEREAS, repaired road access would stimulate existing businesses and livelihoods for lower Kenai Peninsula,

WHEREAS, the repaired road will provide all walks of life easier and more affordable access to State and Federal wilderness parks through access via 17B easements to Port Dick,

WHEREAS, repaired road access would stimulate recreational guide opportunities and recreational use by all citizens of the State of Alaska,

WHEREAS, the repair of the road will stimulate the social well-being and lead to a healthier more robust and vibrant lifestyle of those who live in this remote region of Alaska,

WHEREAS, the road was washed out by disastrous weather events; and

WHEREAS, the Alaska National Guard has the disastrous resources to repair this State of Alaska easement without additional funds from the State of Alaska,

NOW THEREFORE: BE IT RESOLVED THAT: the City Council of the City of Seldovia is in Support of The Repair And Reopening Of Rocky River State Of Alaska Road Easement To The Gulf Of Alaska.

PASSED AND APPROVED by a duly constituted quorum of the City Council of the City of Seldovia, on this 11 day of Nov, 2015.

ATTEST:



Lisa Stanish, City Clerk



APPROVED:



Dean Lent, Mayor

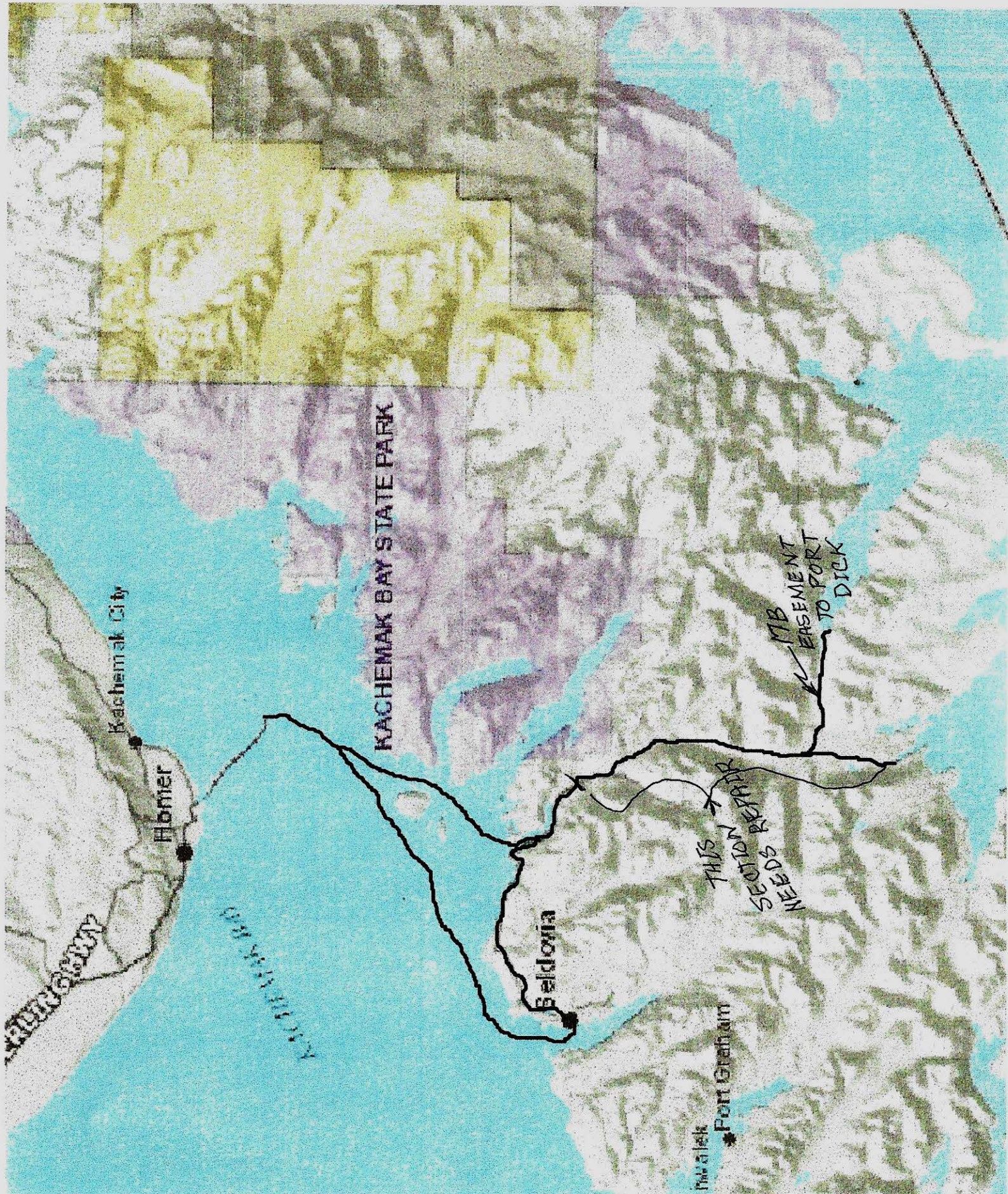

Legend

-  State Park
-  State Wilderness Park
-  State Park Managed Areas
-  Critical Habitat Areas



Disclaimer: This map is prepared by the Alaska Department of Natural Resources for planning purposes and is for graphic representation only. It is intended to be used as a guide and should be used in conjunction with the original survey/conveyance documents and land status records. Source documents remain the official record. The Kachemak Bay State Park boundary has not been surveyed.

The State of Alaska makes no expressed or implied warranties (including warranties of merchantability and fitness) with respect to the character, function, or capabilities of this product or its appropriateness for any user's purposes. In no event will the State of Alaska be liable for any incidental, indirect, special, consequential or other damages suffered by the user or any other person or entity whether from use of the product, any failure thereof or otherwise, and in no event will the State of Alaska's liability to you or any one else exceed the fee paid for the product.

Created on: February 20, 2014
 Created by: DE, Resource Assessment & Development Section
 Projected Coordinate System: NAD 1983, UTM Zone 6 North

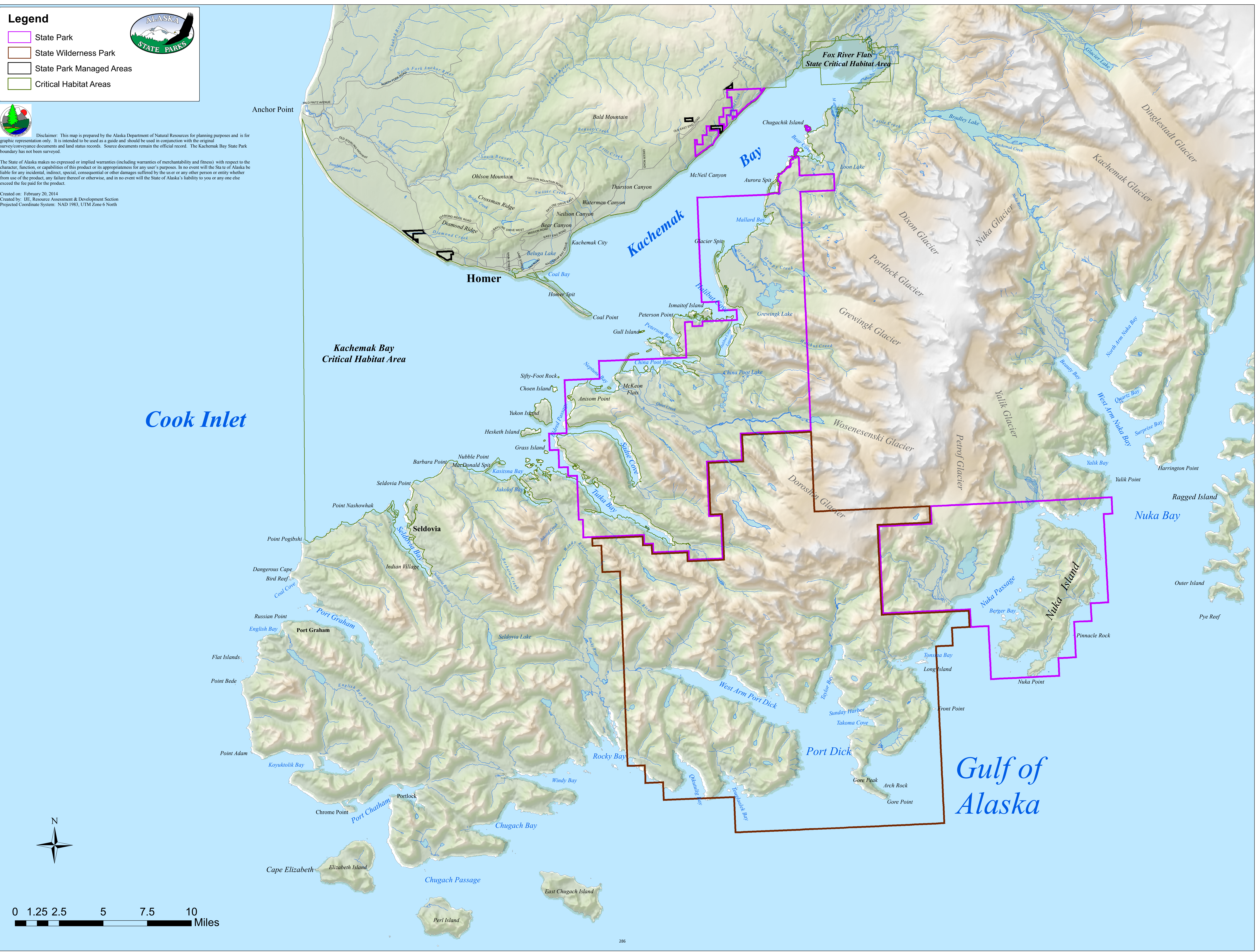

Cook Inlet

Gulf of Alaska

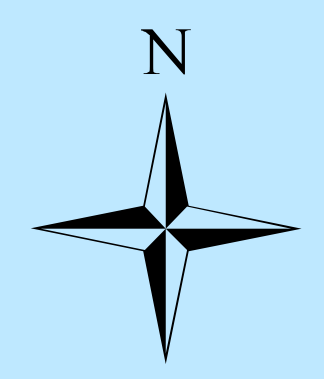
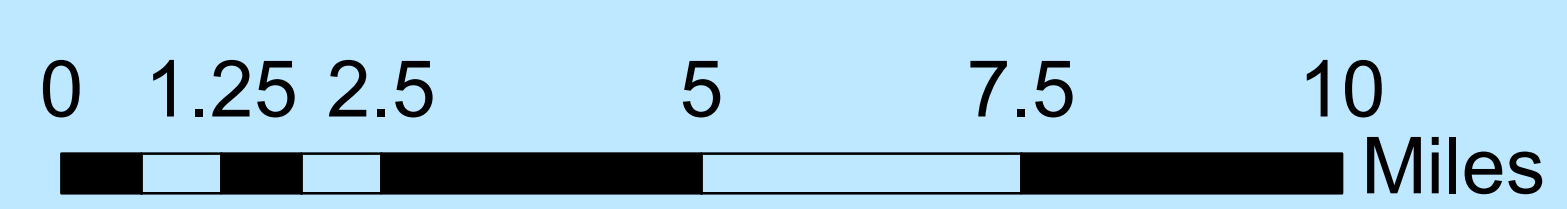

From: [Katie Koester](#)
To: [Jo Johnson](#)
Subject: FW: Rocky River Road Repair
Date: Thursday, December 31, 2015 11:59:05 AM
Attachments: [Signed Chamber Resolution 2015.pdf](#)
[Signed City Rocky River Resolution 11102015.pdf](#)
[2015 Kenai Peninsula Borough Rock River Rd Resolution.pdf](#)
[kbaybasemap.pdf](#)
[2015 Map Sent to Homer City.pdf](#)

Jo,

Please include this email and attached correspondence as back-up for Resolution 15-09

Thanks,

Katie

From: Kris Lethin [<mailto:kwlethin@dancingeagles.com>]
Sent: Tuesday, December 15, 2015 1:48 PM
To: Katie Koester
Cc: Department City Manager; 'Willy Dunne'; exdir@homer.alaska.org
Subject: RE: Rocky River Road Repair

From: Katie Koester [<mailto:kkoester@ci.homer.ak.us>]
Sent: Tuesday, December 15, 2015 10:53 AM
To: Kris Lethin
Subject: RE: Rocky River Road Repair

Hi Mr. Lethin,

The Homer City Council postponed the Resolution at their December 7 meeting requesting more information. Can you help provide me with answers to the following questions?

What standard of road will it be? It is a logging road with wide spots in the road. The road is gravel and dirt. I would say it is a pioneering road. Would vehicles be able to drive on it or only ATVs? In the past most any vehicle could travel the road.

What use with the road have? I think our resolution explains the use of the road. Please refer to the attached resolutions passed by the City of Seldovia, Chamber and the Borough.

Can you provide more details about the funding source? It expected that the source of the funds would come out of the National Guard Training Budget which I believe also has Federal dollars available for training the National Guard. The resolution states that there is already funding available?

How many people would the road serve on a regular basis? I expect that the DOT will keep the road closed in the winter months and do minimal maintenance in the summer. It is any bodies guess as to how many visitors will recreate in and along the road as it a very beautiful area of our Kenai Peninsula. With the needed promotion of the road I could see many folks wanting to explore this area and the State and National Parks next to the road

Can you provide a map of the road? – I think that would be helpful for our Council that is not familiar

with the area. Attached are several maps that I put together.

Thank you for your help.

Best,

Katie Koester
City Manager

From: Kris Lethin [<mailto:kwlethin@dancingeagles.com>]
Sent: Friday, December 11, 2015 10:09 AM
To: Mayor Email; Department City Manager
Subject: Rocky River Road Repair

Follow up. Attached is the resolution passed by the Borough Assembly 12/8. Thank you for considering passage by the Council. Kris

Hi, I am with the Seldovia Chamber of Commerce and we want the Rocky River Road Repaired by the State of Alaska. Please read the attached resolution passed by the Seldovia Chamber. We would appreciate City of Homer passing this resolution or something similar. Your consideration and support would be greatly appreciated. The Borough Assembly, Soldotna Chamber, Homer Chamber and Kenai Peninsula Tourism Council is considering this resolution as well. Thanks You. Kris

Kris & Judith Lethin, Owners
Alaska Dancing Eagles Remote Wilderness Vacation Cabin Rental
Dancing Eagles Services
P.O. Box 264, Seldovia, Alaska 99663-0264
Cell. 907-360-6363, Cell. 907-830-9840
Email: kwlethin@dancingeagles.com
www.dancingeagles.com

NEW BUSINESS



City of Homer

www.cityofhomer-ak.gov

Office of the Mayor

491 East Pioneer Avenue
Homer, Alaska 99603

mayor@ci.homer.ak.us

(p) 907-235-3130

(f) 907-235-3143

Memorandum 16-001

TO: HOMER CITY COUNCIL
FROM: MARY E. WYTHE, MAYOR
DATE: JANUARY 4, 2016
SUBJECT: APPOINTMENT OF A PERSON TO BE NAMED TO THE KENAI PENINSULA ECONOMIC DEVELOPMENT DISTRICT.

On November 19, 1987, the Kenai Peninsula Borough Resource Development (RDC) adopted a resolution recommending to the Assembly that a borough-wide economic development district be formed, with the Borough participating along with the Borough's home-rule, first class, and second-class cities. Kenai Peninsula Economic Development District was organized in 1988. KPEDD serves residents of the Kenai Peninsula Borough in south central Alaska. The Borough is home to approximately 49,600 people residing in a land area of 16,100 square miles. KPEDD has actively pursued development opportunities for the region. Over its lifetime, KPEDD has been involved in a variety of projects, including public works projects, shellfish industry development, international trade, promoting a North Slope Natural Gas Pipeline to Cook Inlet, building infrastructure and industry recruitment.

The City of Homer appoints a representative to the Kenai Peninsula Economic Development District. City Manager Koester has served as Homer's representative on the KPEDD since June 2013.

The seat is for three years, commencing in January 2016 and expiring December 31, 2018.

RECOMMENDATION:

Confirm the appointment of a Person to be Named to the Kenai Peninsula Economic Development District.

Fiscal Note: N/A

RESOLUTIONS

COMMENTS OF THE AUDIENCE
COMMENTS OF THE CITY ATTORNEY
COMMENTS OF THE CITY CLERK
COMMENTS OF THE CITY MANAGER
COMMENTS OF THE MAYOR
COMMENTS OF THE CITY COUNCIL
ADJOURNMENT

