

Kachemak Drive Path Committee

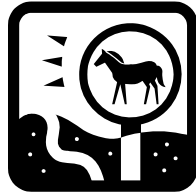

Thursday
February 2, 2012
Regular Meeting 5:30 p.m.



City Hall Cowles Council Chambers
491 E. Pioneer Avenue
Homer, Alaska 99603

**MEETING NOTICE
REGULAR MEETING AGENDA**

- 1. CALL TO ORDER**
- 2. AGENDA APPROVAL**
- 3. APPROVAL OF THE MINUTES**
 - A. Minutes for the Regular Meeting on November 22, 2011 Page 7
- 4. PUBLIC COMMENTS UPON MATTERS ALREADY ON THE AGENDA**
- 5. RECONSIDERATION**
- 6. VISITORS**
- 7. STAFF & COUNCIL/COMMITTEE REPORTS/COMMISSION REPORTS**
- 8. PUBLIC HEARING(S)**
- 9. PENDING BUSINESS**
 - A. Continuing Discussion and Planning for Path Design Page 9
- 10. NEW BUSINESS**
 - A. Memorandum Dated December 7, 2011 re: Re-Formulating the Resolution to Forward to the Commission in January Page 59
 - B. Memorandum dated December 7, 2011 re: Recommendation to Request Salvaged Plastic Walkway Page 65
 - C. Review and Discussion of December 10, 2011 Site Visit Worksession Findings
 - D. Establishing Future Meetings Page 73
- 11. INFORMATIONAL MATERIALS**
 - A. City of Homer Trail Manual Design Criteria Page 75
 - B. Memorandum to Mayor Hornaday and Council from the Homer Advisory Planning Commission dated November 2, 2011 Re: Kachemak Drive Pathway Page 129
- 12. COMMENTS OF THE AUDIENCE**
- 13. COMMENTS OF THE CITY STAFF** *(If present)*
- 14. COMMENTS OF THE COMMITTEE**
- 15. ADJOURNMENT/NEXT REGULAR MEETING IS SCHEDULED FOR FEBRUARY 23, 2012 AT 5:30 P.M.** All meetings scheduled to be held in the Homer City Hall Cowles Council Chambers located at 491 E. Pioneer Avenue, Homer, Alaska.

Minutes, Kachemak Drive Path Committee, November 22, 2011

Attending: Beth Cummings, Kevin Walker (visitor), Bumppo Bremicker (chair), Dave Brann, Lindianne Sarno (recording), Lynn Burt, David Clemens

Call to order, 5:30 p.m. by Bumppo

Agenda approval: Beth moves to approve, Dave Brann seconds, passed.

Minutes approved: Dave Brann moves, Lynn seconds, passed.

Pending Business:

Meeting dates: December 15, 2011, Thursday, 5:30 p.m.

January 11, 2012, Wednesday, 5:30 p.m.

Continuing discussion, planning for path design

Dave Brann shows us a guide to path design from Minnesota Department of Natural Resources and other sources. We are aiming for a ten foot gravel path with sections of wetland and water crossings which will require other techniques. Techniques we are examining are all city approved. Page numbers here refer to hid guide to path design.

Page 27 - bridging, grading discussed. Page 29. NFS means non-frost susceptible. P 6.46, p 6, p. 6.58 boardwalks and bridges, ways to cross drainages. Bridge would be needed to go down to Spit from airport parking lot. That grade is very steep on the road (12%). Regarding airport leasing, there is a 50 foot x 2 DOT right of way.

Dave Brann recommends we use these materials to develop a final packet to present to City Council. Dave will ask Renee if she can create a packet for the committee. He suggests we draw a line on the map and ask Renee to copy it for the committee. Kevin Walker discusses with committee the segment from airport to Spit.

Dave Brann suggests we meet as an announced group and walk that section and other sections. We select December 10, 11-1 p.m. We invite Kevin to join us. Meet at airport parking lot and go to wetlands at other end of path.

Kevin discusses the sheet he created, accurate to +/- 100 feet. We use these numbers to identify suggested areas for trail types. Dave wants to correlate these numbers to the map.

Bring to field day: 100' tape, GPS device, range finder binoculars.

We break for five minutes and reconvene around visitor table. We correlate numbers to map. We will generate even more detail during field trip.

We return to U-shaped table and continue meeting. City council meeting, November 28, Dave Brann and Bumppo will attend, and will advise City Council of level of detail we have attained.

Visitor comments: Kevin is glad to participate

Beth: specifics are wonderful. Is writing to Jennifer Bailey about Aviation Leasing.

Lynn: Excited about specifics

Lindianne: will e-mail dates to Renee, then notes on Monday

David: Excited about field trip

David: Ditto

Bumppo: Ditto

Bumppo adjourns meeting at 8:10 p.m.

Renee Krause

From: Jo Johnson
Sent: Thursday, December 01, 2011 8:40 AM
To: Renee Krause
Subject: FW: Kachemak Drive Path comments
Attachments: 1K-Dr-PathEast-BayClub0+00to41+00.jpg; 2K-Dr-PathBayClub41+00-toArcticTern 85+00.jpg; 3K-Dr-PathArcticTern 85+00-to-Morris111+00.jpg; 4KachDrPathMorris111+00to131.jpg; 6KachDrPath155-172Boatyard.jpg; 7KachDrPathEastEndGearShed.jpg; Easy-to-read-graphic-K-Dr-PathNov30-11.doc; 5KachDrPath131-152.jpg

From: Kevin Walker [<mailto:homerkev@gmail.com>]
Sent: Wednesday, November 30, 2011 10:39 PM
To: Dave and Molly Brann; Beth Cumming; Jo Johnson; Rick Abboud; Julie Engebretsen
Subject: Kachemak Drive Path comments

Dave, Beth, Renee, Rick, and Julie,
Attached is a word document with 7 map files which is my view of where the K-Dr-Path committee is at this point. Renee - could this be distributed to all the members of that committee, plus planning, city council members, and any others that may be interested?

As noted at the beginning of the document, this is a very rough draft, hopefully a guideline for a future packet or document, with some of the basic parameters covered. I'm an interested volunteer, not on the committee. None of these documents have been checked by others.

Please feel free to contact me with any comments or questions.

Kevin Walker
235-5304
homerkev@gmail.com

Kachemak Drive Path comments 11-30-2011

A packet of information is needed to describe in some detail what is being considered by the Kachemak Drive Path (K-Dr-Path) committee. This is a very rough draft, some of the maps / graphics are even rougher, but it is a packet describing where the K-Dr-Path committee is at the end of November, 2011. Better survey data will be required at some time in the future.

These are Kevin Walker's comments from attending most of the K-Dr-Path Committee meetings the past year. Trail access easements will be needed for all private property. The following comments start at the west end of the proposed path, where the existing Homer Spit non-motorized bike path ends. See map sheets 1-6, the first digit of the filename is the sheet number. Again, this is a very rough first draft of a route for the K-Dr-Path.

Stations	Description
Sheet 1	
0+00 to ~5+00	Flat, continue existing Spit Path with separate trail from road
~5+00 to ~11+00	Path is on or near toe of embankment, in and out of trees
~11+00 to ~17+00	Trail climbs to top of hill, exact location to be determined
~17+00 to ~28+00	Path is in back of airport long term parking. Remove junk cars, need airport leasing approval.
~28+00 to 41+00	Adjacent to, but separate from road to Bay Club
Sheet 2	
~41+00 to ~49+00	Bay Club to AP Mgr or boatyard road crossing. Exact crossing location to be determined, check sight distances on road, utility obstacles on north side, driveways, and topography. Follow electric or sewer / water easement.
~49+00 to ~85+00	Road crossing to Arctic Tern. Follow electric easement. Damp ground by Lambert Lake.
Sheet 3	
~85+00 to ~111+00	Arctic Tern to Morris Ave (platted road only). Follow power line? May have to jog to road shoulder to get around private property at ~92+00.
Sheet 4	
~111+00 to ~131+00	Morris Ave thru curves, follow new sewer line easement?
Sheet 5	
~135+00 to ~152+00	Follow new sewer line easement?
Sheet 6	
~152+00 to ~172+00	Follow new sewer line past the Northern Enterprises boatyard. Just past the boatyard there are 2 alternatives. One is to follow a drainage ROW, Davis St, which could require a culvert with the trail on top or a boardwalk, and / or substantial clearing of brush. The second alternative would be keep following Kachemak Drive. See Sheet 7.
Sheet 7	
~172+00 to E-EndRd	The Davis St option would require about 900' of clearing and possible large culvert installation, then another ~300' to get to East End Road through a congested area between the Gear Shed, a coffee shop, and a bike shop, all good terminations for the trail. The Kachemak Drive option would involve building the trail across several driveways, without substantial drainage issues.

Each of these trail segments will need to be examined carefully to determine which type of trail would be built. Several segments could require different types of trail as they may cross wetlands, dry filled land, and roads and driveways.

Design and construction could be performed in stages. The current sewer and water contractor could be contacted to see if some of the work on the east end could be done via change order. Some of the existing environmental permits could possibly be used as only the contractors final landscaping would be changed.

A major task will be to get easement agreements from all landowners. Public Works has many similar easements, some (but definitely not all) with the same landowners in the same locations.

Miscellaneous Notes The maps are somewhat cobbled together using screenprints from the Kenai Borough's Flexviewer program and Google Earth with stationing and labels inserted into the graphics using Microsoft Paint. Paint is somewhat of a mystery to me, but it is on my computer.

The stationing is in feet. 5+00 is 500 feet from 0+00. This is the standard convention for design and construction engineering plans and specifications. This convention is often followed by a designation of how many feet a feature is (Right or Left) from the centerline. This centerline could be from the center of the design alignment, an existing road, or any prominent feature in the project (such as powerline centers, center of sewer or water line, or Right of Way (ROW)).

Following are examples of typical cross sections for various types of trails which could be used on this project. Most are missing some dimensioning text. Several other typical sections have been discussed and will need to be included as the project progresses.

Level 3 trail from page 27 of the City of Homer's Trail Design Criteria Manual.

http://www.cityofhomer-ak.gov/sites/default/files/fileattachments/final_trails_design_criteria_manual.pdf

These typical sections should eventually be finalized and the stations along the trail where they apply will need to be noted with each section.

Include text on all graphics (text didn't cut and paste)

LVL3-Dry.

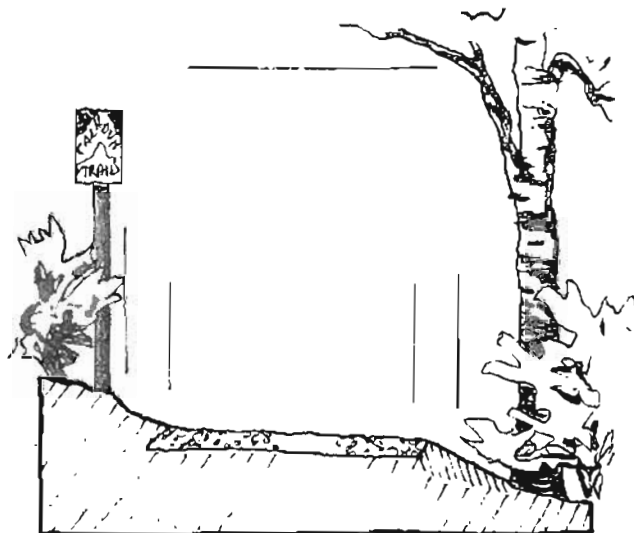

LVL5-Ultimate

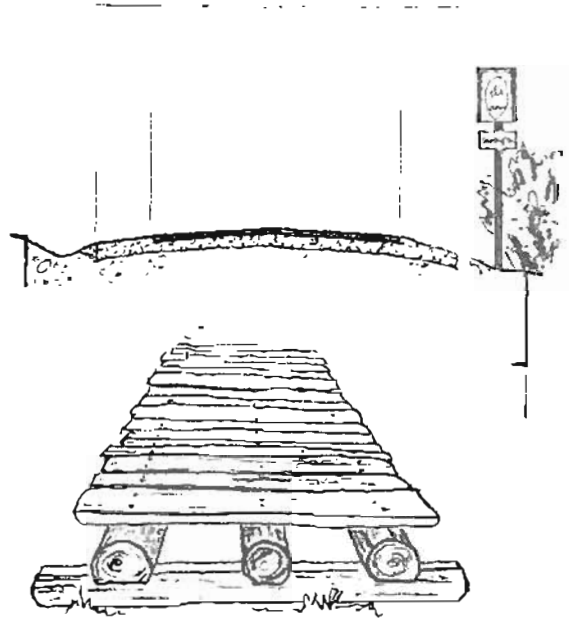

FIGURE D-15 Puncheon Over Wetland



FIGURE D-10 Stone Dip with Turnpike logs

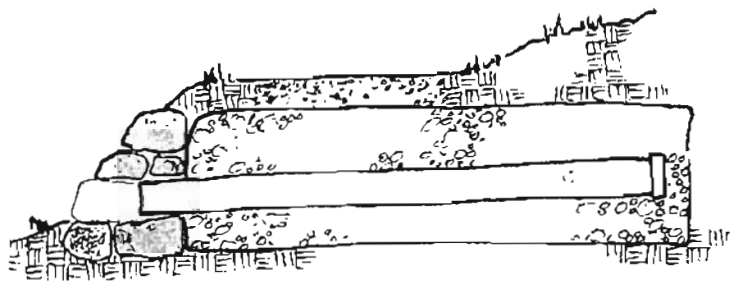

FIGURE D-11 Underdrain, or French Drain

SOURCE OF (some) DRAWINGS: Wetland Trail Design and Construction, USDA Forest Service, 2007.
and
CITY OF HOMER
DESIGN CRITERIA MANUAL

235-5304
homerkev@gmail.com

A PLANNING ESSENTIAL: AN ACCURATE SITE SURVEY

An accurate site survey and analysis are important to the planning process and as much detailed information as reasonably available should be gathered. This consists of a variety of maps, including general base mapping (preferably in GIS format) where multiple overlays of information can be illustrated. Aerial photography (black and white, color, and other forms as available) is also a valuable planning tool. Photos should also be taken from the ground at various vantage points to record site conditions. The following provides an overview of the information that should be included in the site survey and analysis graphic. The level of detail needed depends on the circumstances and the size and scale of the project.

Topography: Relates to grades, elevations, and drainage patterns across the site. Topographic maps typically provide contours on a 2-foot basis. The character and extent of undulation should be graphically illustrated on the site analysis graphic.

Surface Water and Hydrology: Understanding surface water patterns and hydrological flows is critical to designing sustainable trails. The base mapping and site analysis graphic should illustrate:

- Lakes and ponds
- Wetlands
- Ephemeral wetlands
- Rivers, streams, and ephemeral streams
- Floodplains
- Wet meadows and wet slopes
- Springs and seeps
- Drainages and drainage channels

All drainage channels should be identified given their influence on erosion issues, especially for natural surface trends. The size and minimum/maximum normal flow rates and/or water levels should be estimated for each of the items listed above.

Ecologically Sensitive Areas/Vegetative Inventory:

Defining ecologically sensitive areas through a vegetative inventory and land classification is one of the most important aspects of designing trails that are sustainable. (The common methods for doing this are defined in Section 3 – Principles of Ecological Sustainability.) In all cases, sensitive ecological systems should be defined to a level necessary to understand the system and protect its integrity during the planning process. Specific items to identify and avoid impacts to include:

- Critical habitat of endangered, threatened, and special concern species
- Rare, unique, contiguous, or high-value natural areas
- Patches of high-quality and unique habitat
- Riparian areas
- Migratory routes or seasonal use areas for wildlife

Soils: An understanding of soil types where the trail will traverse is important to creating a sustainable trail. This is especially the case with natural surfaced trails, where erosion can be a particular problem. The soil analysis should include:

- Soil types using standard practices; broad characterization (loam, sandy loam, silty loam, sandy clay, etc.) is sufficient for initial planning
- Identification of areas of particular instability or erosion potential as related to the intended use

A more detailed soil study is often needed for load-bearing paved trails and natural surface trail trends where erosion is a major concern.

Property Boundaries and Adjacent Land Uses: Property boundaries and any public or private easements should be recorded on the survey. Identification of current or anticipated adjacent land uses is also important, including how those uses complement or conflict with the trail. All covenants that may exist for the property or adjacent properties should also be recorded.

Administrative Boundaries and Jurisdictions: All special management areas or other jurisdictional boundaries should be recorded as part of the site analysis. This is especially important with respect to resource and wildlife management areas and areas set aside as wilderness or other protective designation.

Distinct Site Edges: On the site analysis, distinct edges of ecologically sensitive areas, water features, or landforms should be identified. These areas tend to be interesting features that could serve as highlights along the trail (within a sustainable context).

Existing Site Features and Anchors: These are physical features of the landscape that would add interest to the trail experience. The site analysis should identify all anchors that could be integrated into the trail design to make for a richer trail experience. Known or potential points of interest, scenic views, recreational use areas, destinations, and so on should all be identified as part of the site analysis.

Cultural Sites: The entire site should be assessed for cultural or historic features that may influence the location of a trail and/or provide a point of interest. This includes European and Native American/tribal cultural site reviews.

Existing Developed/Disturbed Areas: The site analysis graphic should identify all developments on the site and other areas that have been previously disturbed, including:

- Trails, including closed, abandoned, and decommissioned with current use, condition, and estimated level of sustainability defined
- Trailheads and trail access points
- Roads of any type or usage, including abandoned roads (the potential to reuse abandoned roads as part of the trail corridor should be identified)
- Railroads and abandoned railroad grades
- Utility corridors
- Facilities, agricultural operations, buildings, structures, parking areas, campsites, and other human works
- Environmentally disturbed areas (mine sites, dump sites, transportation corridors, etc.)
- Any known locations where existing development or disturbance is causing:
 - Erosion
 - Sedimentation into waterways
 - Wildlife habitat disruption
 - Fish habitat disruption
 - Nonnative plants or noxious weeds

Hazardous Situations: Areas prone to flooding should be identified, including ordinary high water (OHW) level. Unstable or steep slopes should be identified. Any potentially hazardous adjacent land uses should also be recorded, as should hazards posed by operations such as mining, agriculture, railroads, and highways on adjacent land.

Construction/Maintenance Access: All points of access for trail construction and maintenance should be identified on the site analysis.

DESIGN CHARACTER AND STYLES FOR TRAIL STRUCTURES

The design character or style of trail structures is directly influenced by the sense of place exhibited by the site. Structures should be consistent with the context to avoid creating a visual distraction for the visitor. The following considers several different styles for trail structures.

RUSTIC STYLE FOR REMOTE AREAS AND WILDERNESS SETTINGS

In remote or wilderness areas, a rustic style with simple design features that emulate the natural setting is common practice. In these settings, the key principle is to preserve the sense of place and avoid creating a distraction from the innate trail experience.

The use of natural materials for structures prevails in these settings. For example, rough-hewn logs and thick, rough-sawn timber are common materials, as is indigenous stone. The use of waney-edge timber (with bark left on some corners) is also common. Hardware is often heavy-duty steel. Construction techniques are often unrefined, with nothing being absolutely straight, square, or regular. Most components of a structure are not larger or heavier than could conceivably be moved without heavy equipment.

The use of irregularly shaped logs, rough-edged (not square) cut ends on timber, and irregular lengths promotes a more rustic character than mitered joints. On bridges and boardwalks, the deck itself can have variations in level. The use of uneven ends provides a visual break along long straight sections. Using an asymmetric or natural shape for the entire structure is also common, especially if it wraps around an existing anchor such as a series of boulders or trees. Below-ground or ground-contact structures are typically dry-laid or mortared fieldstone. The more anchored the structure is to the site, the more harmonious it feels to the visitor.



This timber boardwalk is simultaneously an anchor, edge, and gateway.



Slightly irregular ends soften the bridge rectangle and vegetation anchors the ends.



Thick timber posts, thinner rails, nonsquare end of posts and rails, and overlapping joints are rustic elements of this pedestrian bridge. The objective of rustic structures is to create a relaxed, natural character by avoiding straight or curvilinear lines, allowing rough materials to shape the details of how parts fit together.

NATURAL STYLE FOR RURAL, NATURAL, OR AGRICULTURAL SETTINGS

Natural style contains many of the same design elements and materials as rustic style, only in a more refined application. In natural-style structures, thick, rough-sawn timber and lumber is often combined with steel, stone, concrete, or masonry to create an appealing form that is consistent with the setting. The character of the structures comes from the texture of materials, overlapping ends and visual breaks in long lengths, irregular edges, and occasional curves or dogleg segments. Salvaged or reused materials are also often used, especially those that are weathered or otherwise have a harmonious natural character.

Since materials may be less natural than in rustic construction, designing natural shapes into the structure and anchoring it in the site are very important for harmony. Topography, rocks, large trees, vegetation, or combination often anchor natural-style structures to the site. Planted vegetation is often used to anchor the points where the structure touches the ground. Allowing unpainted materials to weather is also common.

For more information!

Check out the DNR website for wetlands and the regulatory framework in Section 1 – Framework for Planning Sustainable Trails for more information on requirements associated with protecting Minnesota's wetlands and water bodies.



Preserving wetland and lake systems is at the core of Minnesota's ecological protection strategy. Routing trails to avoid or at least minimize impacts to these resources is a key underpinning of sustainable trail development.

WETLAND TYPING, DELINEATION REQUIREMENTS, AND PROTECTION STRATEGIES

The Wetland Conservation Act (WCA) maintains and protects Minnesota's wetlands and the benefits they provide. Enacted in 1991, it is one of the most sweeping wetlands protection laws in the country. The Legislature has amended the WCA significantly three times, mostly to accommodate the varying needs of the different geographic areas of Minnesota.

Local government units – cities, counties, watershed management organizations, soil and water conservation districts, and townships – implement the act locally. The Minnesota Board of Water and Soil Resources (BWSR) administers the act statewide, and the DNR enforces it.

The WCA recognizes the value of a number of wetland benefits, including:

- Water quality, including filtering pollutants out of surface- and ground-water, using nutrients that would otherwise pollute public waters, trapping sediments, protecting shoreline, and recharging groundwater supplies
- Floodwater and storm water retention, including reducing the potential for flooding
- Public recreation and education, including hunting and fishing, wildlife viewing, and experiencing nature
- Commercial benefits, including wild rice and cranberry growing and aquaculture
- Fish and wildlife benefits and low-flow augmentation during times of drought

To retain the benefits of wetlands and reach the goal of no net loss of wetlands, the WCA requires anyone proposing to drain, fill, or excavate a wetland to first try to avoid disturbing the wetland; second, try to minimize any impact on the wetland; and, finally, to replace any lost wetland acres, functions, and values. Certain wetland activities are exempt from the act, allowing projects with minimal impact or projects on land where certain preestablished land uses are present to proceed without regulation.

WETLAND TYPES IN MINNESOTA

Nationally, there are several wetland classification systems. In Minnesota, the U.S. Fish and Wildlife Service Circular 39 Classification System is commonly used. Under this system, eight wetland types are recognized in Minnesota, not including rivers and lakes. The following provides an overview of each of these.

Type 1 - Seasonally Flooded Basin or Flat

Soil: Usually well drained during much of the growing season

Hydrology: Covered with water or waterlogged during variable seasonal periods

Vegetation: Varies greatly according to season and duration of flooding from bottomland hardwoods to herbaceous plants

Common sites: Upland depressions, bottomland hardwoods (floodplain forests)

National wetland inventory (NWI) symbols: PEMA, PFOA, PUS



Seasonally flooded basins may be kettles in glacial deposits, low spots in outwash plains, or depressions in floodplains. They are frequently cultivated.

When these basins are not cultivated, wetland vegetation can become established, including smartweeds, beggarlicks, nut-grasses, and wild millet.

Type 2 - Wet (Sedge) Meadow

Soil: Saturated or nearly saturated during most of the growing season

Hydrology: Usually without standing water during most of the growing season but waterlogged within at least a few inches of the surface

Vegetation: Grasses, sedges, rushes, various broad-leaved plants

Common sites: May fill shallow basins, sloughs, or farmland sags; may border shallow marshes on the landward side and include low prairies, sedge meadows, and calcareous fens

NWI symbols: PEMB



Sedge meadows are dominated by the sedges growing on saturated soils. The forb species are diverse but scattered, and may flower poorly under intense competition with the sedges.

Soils are usually composed of peat or muck. Some sedges form hummocks.

Sedge meadows often grade into shallow marshes, calcareous fens, wet prairies, and bogs.

Type 3 - Shallow Marsh

Soil: Usually waterlogged early in the growing season

Hydrology: Often covered with 6 inches or more of water

Vegetation: Grasses, bulrush, spikerush, and various other marsh plants, such as cattail, arrowhead, pickerelweed, and smartweed

Common sites: May nearly fill shallow lake basins or sloughs; may border deep marshes on landward side, commonly as seep areas near irrigated lands

NWI symbols: PEMC and F, PSSH, PUBA and C



Shallow marsh plant communities have soils that are saturated to inundated by standing water up to 6 inches in depth throughout most of the growing season.

Herbaceous emergent vegetation such as cattails, bulrushes, arrowheads, and lake sedges characterize this community.

Type 5 - Shallow Open Water

Soil: Inundated

Hydrology: Usually covered with less than 10 feet of water; includes shallow ponds and reservoirs

Vegetation: Fringe of emergent vegetation similar to open areas of Type 4

Common sites: Shallow lake basins; may border large open water basins

NWI symbols: LI; L2ABG and H; L2EMA, B, and H; L2RS; L2UB; PABH; PUBG and H



Submergent, floating, and floating-leaved aquatic vegetation including pondweeds, waterlilies, water milfoil, coontail, and duckweeds characterize this wetland type. Floating vegetation may or may not be present. Shallow open-water communities seldom, if ever, draw down. These communities provide important habitat for many species.

Type 7 - Wooded Swamp

Soil: Waterlogged within a few inches of the surface during the growing season

Hydrology: Often covered with as much as 1 foot of water; water table is at or near the surface

Vegetation: Hardwood and coniferous swamps with tamarack, northern white cedar, black spruce, balsam fir, balsam poplar, red maple, and black ash; deciduous sites frequently support beds of duckweed and smartweed

Common sites: Mostly in shallow ancient lake basins, old riverine oxbows, flat terrains, and along sluggish streams

NWI symbols: PFO1, 5, and 6B; PFOC and F



Wooded swamps are forested wetlands dominated by mature conifers and lowland hardwood trees. This includes the northern wet-mesic forest and the southern wet- and wet-mesic hardwood associations.

Wooded swamps are important for stormwater and floodwater retention. They also provide habitat for wildlife including white-tailed deer, furbearers, songbirds, ruffed grouse, barred owl and amphibians.

Type 4 - Deep Marsh

Soil: Inundated

Hydrology: Usually covered with 6 inches to 3 feet or more of water during growing season

Vegetation: Cattail, reed, bulrush, spikerush, and wild rice; open areas may have pondweed, naiad, coontail, watermilfoil, waterweed, duckweed, waterlily, and spatterdock

Common sites: May completely fill shallow lake basins, potholes, limestone sinks, and sloughs; may border open water

NWI symbols: L2ABF, L2EMF and G, L2US, PABF and G, PEMG and H, PUBB and F



Deep marsh communities have standing water depths of between 6 inches and 3 or more feet during the growing season.

Herbaceous emergent, floating and floating-leaved, and submergent vegetation compose this community, with the major dominance by cattails, hardstem bulrush, pickerelweed, giant bur-reed, Phragmites, wild rice, pondweeds and waterlilies.

Type 6 - Shrub Swamp

Soil: Usually waterlogged during growing the season

Hydrology: Often covered with as much as 6 inches of water; water table is at or near the surface

Vegetation: Includes alder, willow, buttonbrush, dogwood, and swamp privet

Common sites: Along sluggish streams, and drainage depressions; occasionally on floodplains

NWI symbols: PSSA, C, F, and G; PSSI, 5, and 6B



Shrub swamps are wetland plant communities dominated by woody vegetation less than 20 feet high and with a dbh of less than 6 inches. Shrub swamps of Minnesota are categorized as shrub-carrs and alder thickets depending on the dominant shrub species. Both occur on organic soils (peat/muck) as well as on the alluvial mineral soils of floodplains.

Type 8 - Bogs

Soil: Usually waterlogged

Hydrology: Water table at or near the surface

Vegetation: Woody, herbaceous, or both supporting a spongy covering of mosses; typical plants are heath shrubs, sphagnum mosses, sedges, leatherleaf, Labrador tea, cranberry, and cottongrass; may include stunted black spruce and tamarack

Common sites: Mostly on shallow glacial lake basins and depressions, flat terrains, and along sluggish streams

NWI symbols: PFO2, 4, and 7B; PSS2, 3, 4, and 7B



Bogs are found on saturated, acid peat soils that are low in nutrients and support a unique assemblage of trees, low shrubs, and herbs on a mat of sphagnum moss. Bogs are one stage in succession from open water lake to climax mesic hardwood forest. They originate on a floating mat of sedges that becomes colonized by sphagnum mosses.

D. TRAIL DESIGN CRITERIA

7. WETLANDS, WATER CROSSINGS & DRAINAGE

a. General Crossing Criteria for all Trails:

- Route the trail to minimize the number and length of crossings;
- Allow for water to pass freely under the trail, with minimal use of piping, culverts, or other constructed passage;
- Best alignment for crossing rivers, streams, and creeks: At a 90° angle on high ground, at a narrow point along the stream and away from curves or eroding soils;
- Best methods for seeps, saturated soils and wetlands: minimize crossing distance, avoid the need for fill, elevate and construct the structure to allow flow of water and growth of plant materials;
- All crossings shall be as wide as the approaching trail, with 1-2 feet additional clearance on each side, depending on the volume and type of users, and the level of the trail.

b. Crossing Techniques

Many techniques are available for use in crossing wet areas along trails. Choose the crossing technique that best suits the users, the volume of use, the trail level, and the specific location. For additional guidelines on wetland crossings, see USDA Forest Service manual titled Wetland Trail Design and Construction, 2007. An investigation of soils and water will help avoid surprises when constructing trails in

the hillside terrain. Problematic soil conditions may not be visible until a trail has experienced heavy use.

FIGURE D-10

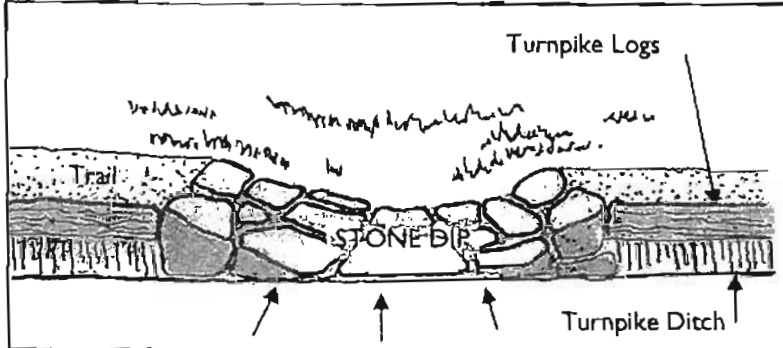

i) **Dips.** Simple and effective ways to drain wet areas. The slope angle and depth vary with soil and water conditions. Stones help reinforce the dip. Geotextile may be installed underneath to prevent fines from washing out.

FIGURE D-11 Underdrain, or French Drain

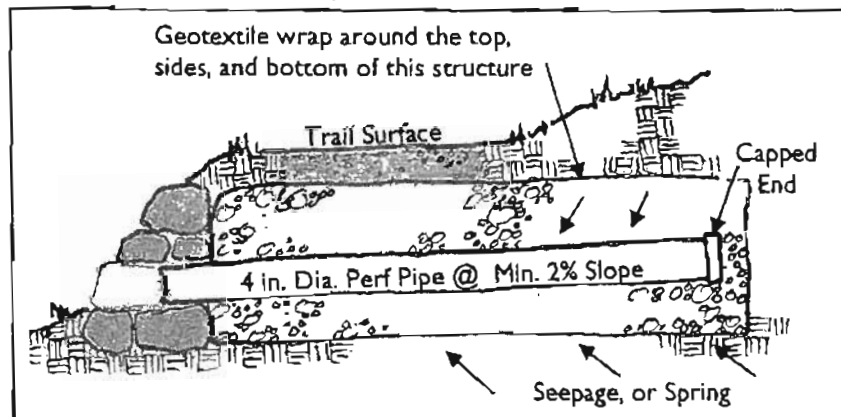

ii) **French Drains or Underdrains.** For crossings over areas of low flow, on low level trails. Trail is constructed over a bed of round rock and perforated pipe, covered with fabric.

SOURCE OF DRAWINGS:
Wetland Trail Design and Construction, USDA Forest Service, 2007.

D. TRAIL DESIGN CRITERIA

iv) **Planks with Piles, Cribbing or Bents.** An elevated trail technique where one or more tread planks are laid parallel to the trail corridor, attached to piles, cribbing, or bents. Choice of support method depends on type of wetland, range of water depth, user volumes, size of trail. Piles are not recommended on low level trails, due to the depth needed to prevent frost heaving.

v) **Puncheons.** A crossing technique for low water areas that utilizes sleepers. Some have linear planks, others also have stringers to support perpendicular decking, which is necessary for bicycle travel.

vi) **Boardwalks.** These are the most substantially constructed form of elevated crossings. They use piles, diagonal bracing, stringers, and planking laid perpendicular to the direction of travel. They often include curbed edges or railings, and can be constructed to suit many user groups, including bicycles and wheelchairs.

vii) **Other Techniques.** Avoid using ditches, culverts or other channelization techniques to divert water, as they may create issues with landslides and super-saturation of soils. Corduroy, turnpikes and causeways are all variations of at-grade wetland crossings, each with their pros and cons. Use of these may be appropriate in some situations, but they are typically not the most environmentally friendly.

c. Materials

Choose materials that are long-lasting and environmentally safe. More investment is expected on higher level trails.

FIGURE D-12 Log Cribbing with Two Sleepers

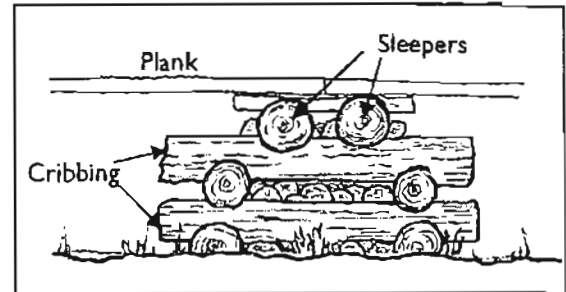

FIGURE D-13 Bog Bridge with Sleepers, or Single Plank Boardwalk

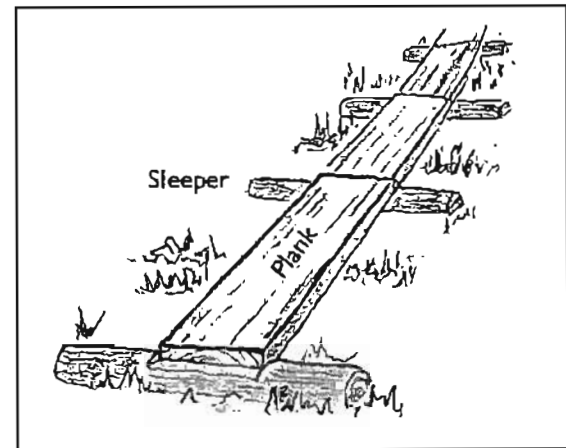

FIGURE D-15 Puncheon

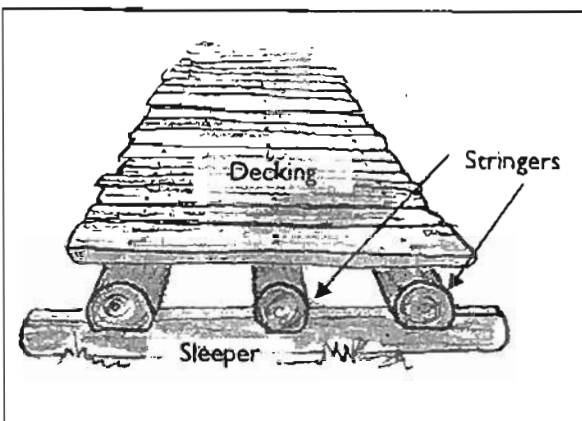
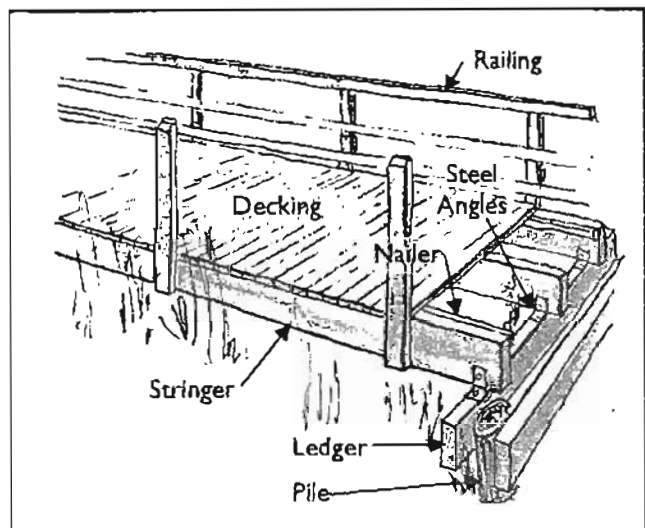

FIGURE D-14 Boardwalk



SOURCE OF DRAWINGS: Wetland Trail Design and Construction, USDA Forest Service, 2007.

Turn

Geotextile Placement

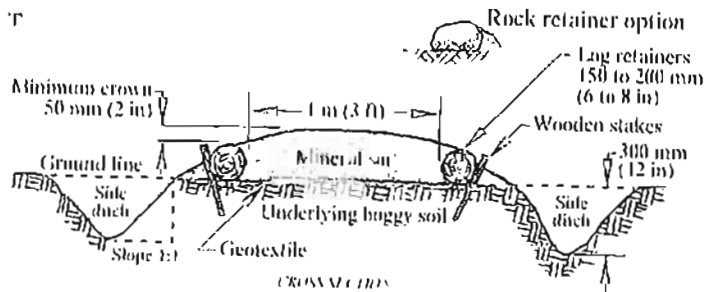

Figure 41 Place geotextile under the retainer logs or rocks before staking the geotextile in place.

Construct a dip or a drainage structure at each end of the turnpike where necessary to keep water from flowing onto the structure. Keep the approaches as straight as possible coming onto a turnpike, to minimize the chance that stock or motorbike users will cut the corners and end up in the ditches. Turnpike maintenance, especially recrowning, is particularly important the first year after construction; the soil will have settled then. Make sure the ditches are cleaned out and are deep enough to drain the turnpike (figure 42).

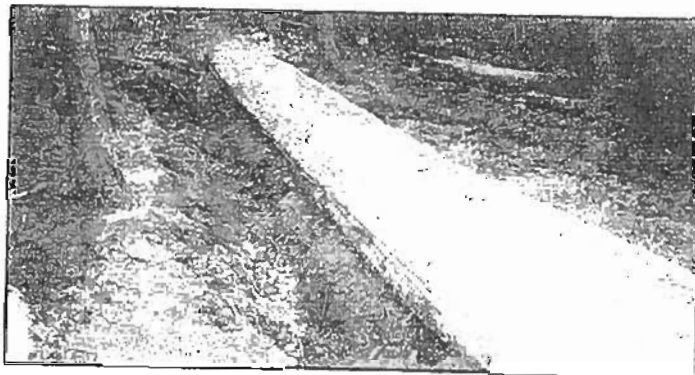

Figure 42 Turnpike maintenance includes recrowning the tread, cleaning out the ditches, and making sure the ditches are deep enough.

An alternative method, one that not only provides separation between good fill and clay but also keeps a layer of soil drier than the track beneath, is called encapsulation, or the *sausage encapsulation technique* (figure 43). Excavate 250 to 300 millimeters (10 to 12 inches) of track from the middle of the turnpike. Lay down a roll of geotextile the length of the turnpike. The geotextile should be wide enough to fold back over the top with a 300-millimeter (1-foot) overlap. Place 150 millimeters (6 inches) of good fill, or even rocks, on top of the single layer of geotextile, then fold the geotextile back over the top and continue to fill with tread material. Rocks or logs can be used for retainers. Rocks last longer.

Sausage or Encapsulation Technique

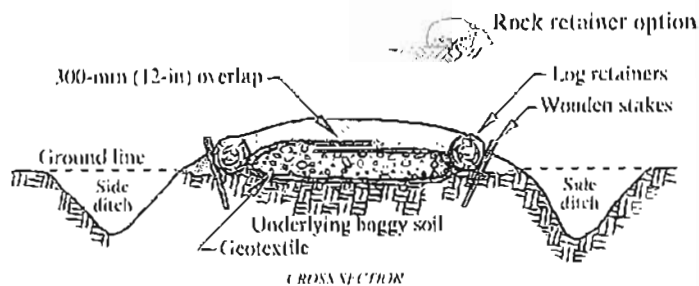

Figure 43 Sausage encapsulation is another way to raise a trail above wet

An alternative method, one that usually provides separation between good fill and clay but also keeps a layer of soil drier than the muck beneath, is called encapsulation, or the *sausage encapsulation technique* (Figure 43). Excavate 250 to 300 millimeters (10 to 12 inches) of muck from the middle of the turnpike. Lay down a roll of geotextile the length of the turnpike. The geotextile should be wide enough to fold back over the top with a 300-millimeter (1-foot) overlap. Place 150 millimeters (6 inches) of good fill, or even rocks, on top of the single layer of geotextile, then fold the geotextile back over the top and continue to fill with tread material. Rocks or logs can be used for retainers. Rocks last longer.

Sausage or Encapsulation Technique

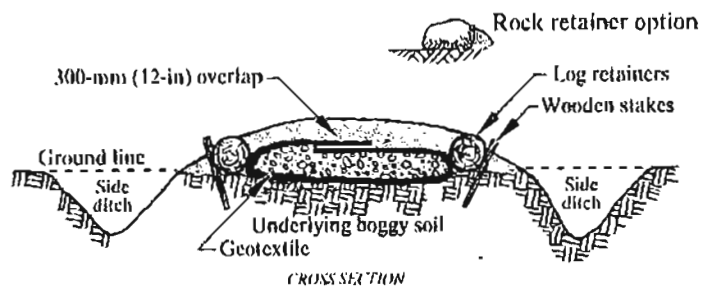

Figure 43—Sausage encapsulation is another way to raise a trail above wet areas.

If you use logs, they should be at least 150 millimeters (6 inches) in diameter and peeled. Lay retainer logs in one continuous row along each edge of the trail tread. The logs can be joined by notching them (figure 44). In some species, notching may cause the logs to rot faster. Anchor the logs with stakes (figure 45) or, better yet, large rocks along the outside. Anchors are not needed on the inside, because the fill and surfacing will hold the retainer logs.

The most important considerations are to keep the water level below the trail base and carry the water under and away from the trail at all.

SHARED-USE PAVED TRAILS

Shared-use paved trails typically accommodate pedestrians, bicyclists, in-line skaters, and wheelchair users. The following profiles define the preferences of those using shared-use paved trails.

BICYCLISTS PROFILES

The following profiles were compiled from various sources, particularly the *Profiles of Trail User Populations - Minnesota Border to Border Trail Study* (DNR) to highlight the preferences of typical bicyclists.

Type	Preference Profile
Family Bicyclist	<p>Trail Use Pattern:</p> <ul style="list-style-type: none"> • Prefers bike trails and quiet streets (to avoid heavy traffic), with preference for trails if conveniently located • Most activity happens close to home, but will also use trails extensively on vacation <p>Recreation Setting Preferences:</p> <ul style="list-style-type: none"> • Controlled, traffic-free access to trails is most important consideration • Quality of the riding experience is of primary importance, with length being secondary (20 miles maximum) • Connections to parks and playgrounds are important <p>Motivation/Activity Style Elements:</p> <ul style="list-style-type: none"> • Rides in family groups, often including small children • Needs good information for planning trips and access to support facilities (rest areas, parking lots, water sources) and prefers restrooms to portable toilets • Prefers scenic areas but no challenging terrain, especially when children are along
Recreational Bicyclist	<p>Trail Use Pattern:</p> <ul style="list-style-type: none"> • Seeks out and travels to trails and bicycle-friendly areas away from home, either as a day or overnight trip • Prefer trails, but will also use roads that are safe, convenient, and not too busy <p>Recreation Setting Preferences:</p> <ul style="list-style-type: none"> • Trails shorter than 10 miles are not very desirable for repeat use; 20 miles is the desired minimum • Looped configurations of varying lengths are preferred over out and back systems • Sense of place and an interesting experience are important, with riders seeking places with scenic quality and interesting natural or (if in urban setting) built forms <p>Motivation/Activity Style Elements:</p> <ul style="list-style-type: none"> • Many seek escape from motorized traffic and value experiencing nature • Regards bicycling as an important recreational interest and is willing to make an investment in equipment • Often uses amenities, such as parks and rest areas, along the trail • As a group, interested in varying levels of trail difficulty • Destinations at reasonable distances are important to maintaining interest in a given trail
Fitness Bicyclist	<p>Trail Use Pattern:</p> <ul style="list-style-type: none"> • Will use a combination of roads and trails that are long and/or challenging enough for a good workout • Prefers trails if they are long enough (20 or more miles) and allow for faster speeds with minimal user conflicts • Will routinely use the same routes for challenges and timing, often daily <p>Recreation Setting Preferences:</p> <ul style="list-style-type: none"> • Trails need to offer varying difficulty and lengths; interconnected loops are highly preferred • Not primarily motivated by experiencing natural setting, but will select this type of trail if other requirements are met <p>Motivation/Activity Style Elements:</p> <ul style="list-style-type: none"> • Uses bicycle as primary form of exercise to maintain and improve health • Primarily rides alone or in small groups and often rides multiple times per week • Frequently extends the season by riding earlier in spring and later in the fall than recreational riders
Transportation Bicyclist	<p>Trail Use Pattern:</p> <ul style="list-style-type: none"> • Not dependent on trails, but will use them if convenient, safe, and direct <p>Motivation/Activity Style Elements:</p> <ul style="list-style-type: none"> • Bicycle is used as a form of transportation; motivation is fitness, environmental values, and economy • Lack of a safe "system" of roads (with bike lanes or routes) and trails is a major barrier • Trail design is critical, with ability to go fast with good sightlines and directness being most important

Bike Route

A bike route is a shared portion of the roadway that provides some separation between motor vehicles and bicyclists. State statutes define a bike route as a "roadway signed for encouragement of bicycle use." Most people would recognize a bike route as a paved shoulder with signage. A minimum of 4 feet is the recommended shoulder width for roadways where bicycles are present. A 6-foot shoulder is recommended once traffic speeds exceed 50 mph. If rumble strips are provided on the edge of the drive lane, the smooth biking surface should be at least 5 feet wide.

Most bikeways in suburban or rural settings will be designated as bike routes. The need for designated bike lanes is most often associated with downtown areas and major business districts in urban core areas where traffic is heavy. The following photos illustrate the most common bike routes.



Bike route in narrower, slower speed roadway. Where space is limited and traffic speeds are 30 MPH, such as along this scenic byway, a minimum shoulder width of 4 feet would be adequate.



Bike route on wider, higher speed roadway. Once speeds get above 50 mph, a minimum 6 foot shoulder is recommended to provide reasonable separation between bicyclists and motor vehicles.

BIKEWAY CONFIGURATIONS

There are no set standards for the configuration of a bikeway. The primary determinant is the likelihood that bicyclists will use a particular road based on its directness, accessibility from a given location, continuity, comfort and attractiveness, and, above all, perception of safety. In many communities, bikeways are established in a de facto manner as part of roadway projects where paved shoulders are provided for operational safety and maintenance. Where this is the local policy, coordination between trail planners and roadway engineers is critical to ensuring that any nuances associated with bikeways are factored into the design of the roadway at the point of construction planning. Through this approach, many cities have successfully expanded bikeway systems without substantial capital expenditures.

As a general guide, the *Mn/DOT Bikeway Facility Design Manual* provides tables that relate bikeway types to roadway characteristics, as the following illustrates.

BIKEWAY DESIGN OPTIONS FOR ROADWAYS

The following tables provide recommended bikeway design options for various roadways. The tables relate to urban section (with curb and gutter) and rural section (no curb and gutter) roadways. Note that *wide curb lane* refers to a right through-traffic lane is wider than 12 feet. *Shared lane* relates to travel lanes that can be legally used by bicyclists, but are less than 12 feet. ADT relates to average daily motor vehicle traffic.

		ADT (2 lane)						
		< 500	500-1,000	1,000-2,000	2,000-5,000	5,000-10,000	>10,000	
Urban Section Guidelines		ADT (4 lane)						
		N/A	N/A	2,000-4,000	4,000-10,000	10,000-20,000	>20,000	
Posted Speed	< 30 mph	Shared lane	Wide curb lane	Wide curb lane	Bike lane	Bike lane	Bike lane	
	30 mph	Shared lane	Wide curb lane	Bike lane	Bike lane	Bike lane	Bike lane	
	35-40 mph	Wide curb lane	Bike lane	Bike lane	Bike lane	Bike lane	Bike lane	
	> 40 mph	Bike lane	Bike lane	Bike lane	Bike lane	Bike lane	Bike lane	
Rural Section Guidelines		ADT/Lane						
		< 1000*	1,000-2,500	2,500-5,000	5,000-10,000	>10,000		
		< 30 mph	4' paved shoulder	4' paved shoulder	4' paved shoulder	4' paved shoulder	6' paved shoulder	
		30-35 mph	4' paved shoulder	6' paved shoulder	6' paved shoulder	6' paved shoulder	8' paved shoulder	
		35-45 mph	6' paved shoulder	6' paved shoulder	6' paved shoulder	8' paved shoulder	10' paved shoulder	
> 45 mph	6' paved shoulder	6' paved shoulder	8' paved shoulder	10' paved shoulder	10' paved shoulder			

* Shoulders are not necessary when the ADT is less than 500, unless the roadway is heavily used by truck or heavy commercial vehicles. In these situations, bicyclists should be accommodated with a shared lane.

TRAIL SOLUTIONS – IMBA'S GUIDE TO BUILDING SWEET SINGLETRACK

Published by IMBA, this resource provides user-friendly guidelines on building high-quality mountain bike trails. Find it at www.imba.com/resources/trail_building/trail_solutions.html.

FOREST SERVICE TRAILS REPORTS 2004

This collection of reports related to trails covers a wide variety of subjects pertinent to developing natural surface trails. A CD-ROM of the reports is available at www.fhwa.dot.gov/environment/recreails/trailpub.htm, under the publication 0423-2C03-MTDC Forest Service Trail Reports 2004.

GENERAL DESIGN GUIDELINES AND CONSIDERATIONS

The following guidelines provide general design parameters for creating sustainable natural surface trails. These guidelines are not intended to be a substitute for site-specific design that responds to local conditions and safety concerns.

TRAIL TREAD WIDTHS

The physical space required for different trail users provides the base-line for determining the optimal width for a trail. Even within a given classification, site-specific circumstances often require alternative configurations to accommodate the anticipated types and levels of use. The graphics on this and the following page illustrate the basic trail width requirements for different types of uses associated with natural surface trails.

TYPICAL TRAILS WIDTHS FOR NATURAL SURFACE TRAILS – NONMOTORIZED USES

Trail widths vary considerably depending on type of use and whether a trail is single or double track and one or two directions. Trail width must also be based on a solid understanding of how a trail will be used since over time it will take the shape users give it irrespective of how it was originally designed. This is a distinct difference between paved and natural trails and must be accommodated in trail design. The following defines the basic trail widths and directional configurations for each type of natural surface trail use.

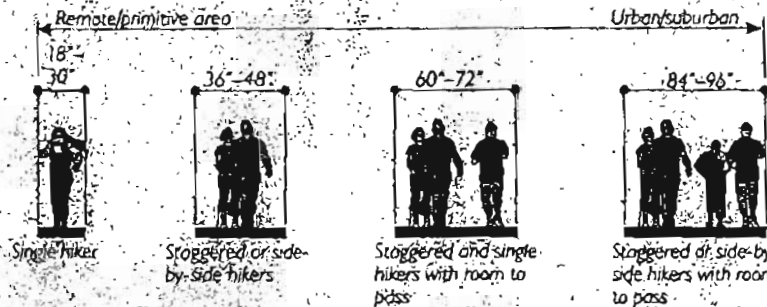

Hikers walk alone, staggered, or side by side, depending on the setting and character of the trail. The more remote or primitive an area, the narrower and more rugged the trail tends to be. In more urban areas, hiking trails tend to be wider due to heavier levels of use. For hiking-only trails, a width more than 96 inches (8 feet) is uncommon.

Typical Hiker

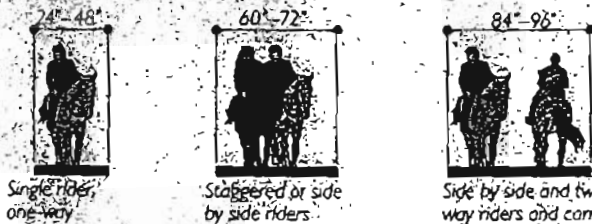

Horseback riders walk single-file, staggered, or side by side, depending on the setting and character of the trail. As with hiking, the more remote or primitive an area, the narrower and more rugged the trail tends to be. In regional and state parks and along linear trail corridors, equestrian trails tend to be wider due to heavier levels of use and the desire to ride side by side. Carriage trails need to be at least 8 feet wide, plus a shoulder.

Typical Horseback Rider



Mountain biking trail widths typically correspond to the trail rating system for difficulty as defined in Section 4 - Trail Classifications and General Characteristics. Two-direction trails are typically easier and wider trails.

Typical Mountain Biker

TRAIL WIDTHS AND CONFIGURATIONS

Trail widths and configurations vary for each of the listed trail classifications. Even within a given classification, site-specific circumstances often require alternative configurations to accommodate the anticipated types and levels of use. The following provides guidelines for determining the appropriate width and configuration for a given situation.

BASIC PHYSICAL INTERRELATIONSHIPS BETWEEN TRAIL USERS

The physical space required for different trail users provides a base-line for determining the optimal width for a given trail. Trail widths increase in line with use levels and the diversity of users being accommodated. The following graphic illustrates the relationships between trail users and trail width.

RELATIONSHIP BETWEEN TRAIL USERS AND TRAIL WIDTHS ON MULTIPURPOSE PAVED TRAILS

BASIC TRAIL USER SPACE REQUIREMENTS

The typical space requirements for common trail uses are shown below. The dimensions denote operating space, which includes the physical space needed for basic maneuvering.

Typical Pedestrian (Walker/Jogger)

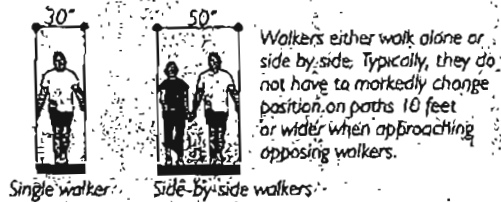

Typical Bicyclist

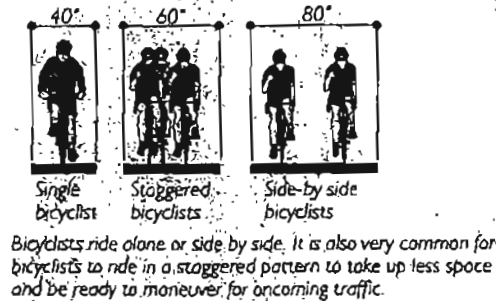

Typical In-line Skater

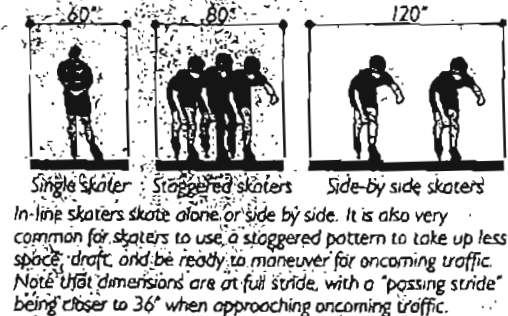

Typical Wheelchair User

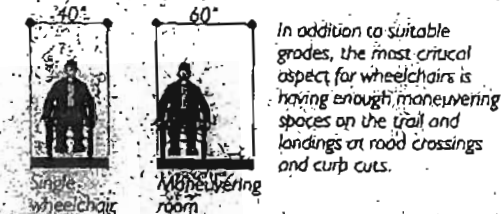

TRAIL WIDTHS REQUIRED TO ACCOMMODATE VARIOUS COMBINATIONS OF TRAIL USERS

Trail widths should be based on the public values offered and a clear understanding of the type of users that will be drawn to it and accommodated. For example, if the setting is scenic, location convenient, and/or length is suitable for elite users, the trail will likely attract many types of users with various skill levels. The trail's width must be based on these realities if the trail is to be successful. Doing otherwise could lead to higher levels of conflict, an increased propensity for accidents, and general visitor dissatisfaction - none of which is a desirable end.

Typical Two-Directional Trails at Various Widths



As trails widen, people begin to use them differently. Understandably, the most successful trails are those that accommodate the patterns of use people are inclined toward. At a neighborhood level, a "strolling width" is appropriate. On a major trail, the expectations of more specialized users and higher volumes of use should rightfully be accommodated.

Typical Shared-use Separated Trails

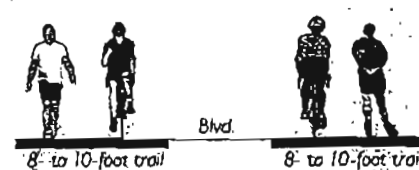

The first level of separated directional trails has shared uses going in a common direction, as illustrated. This is most common in wide-open areas with moderately heavy use patterns.

Typical Designated Use and Direction Trails

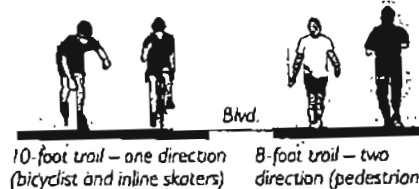

The second level of directional trails separates bicyclists and in-line skaters from walkers and joggers. Bicyclists and in-line skaters are limited to one direction. This is most common around an urban recreational lake or loop within a popular park where users can return to their starting point.

Typical One- and Multi-Directional Trails - Designated Use



The third level of directional trails continues to separate bicyclists and in-line skaters from walkers and joggers. Bicyclists and in-line skaters are separated but can go both directions. This is typically used to create a bicycle "freeway" in major urban areas where use levels are high and space is less limited.

GENERAL GUIDELINE FOR TRAIL-BUILDING PROCESS

The process for developing high-quality natural surface trails centers around two important considerations:

Defining the user group(s). Each type of user group brings with it trail development nuances that must be considered if the trail is to be sustainable with minimal maintenance.

2. **Planning a route that is sustainable and enjoyable.** An interesting, exciting, and rewarding route is critical to trail success and sustainability. If trails do not meet user expectations, the likelihood of bypassing and creating new routes increases. With higher impact uses, bored users are more likely to use the trail recklessly and cause additional impacts to surrounding vegetation.

BASIC STEP-BY-STEP PROCESS FOR DEVELOPING TRAILS

The following outlines the basic step-by-step process for developing a natural surface trail. These steps complement the trail project planning guidelines in Section 1 - Framework for Planning Sustainable Trails, which should be referred to for more extensive checklists and standard requirements when developing a trail. IMBA's *Trail Solutions* is also a suggested reference, especially when laypersons are involved in building a trail with hand tools and require a basic understanding of the process. Typical trail-building steps include:

1. **Confirm property limits** -- to ensure that the trail is being built on the right property.
2. **Confirm trail users** -- to understand the exact trail requirements and the design parameters that must be applied. Refer to Section 4 - Trail Classifications and General Characteristics to determine the specific requirements and layout considerations for each type of use. This also includes defining the different type of users within each group. For example, trails within a designated OHV recreation site are often designed to a different standard than a designated OHV trail.
3. **Layout the trail** -- including control points and desired places to visit and avoid. Loop configurations, trail flow, and rolling grade character are all important factors in creating an appealing trail. (Refer to Section 2 - Principles of Designing Quality Recreational Trails and Section 4 -- Trail Classifications and General Characteristics for pertinent information on creating trails that will meet user expectations.)
4. **Flag the trail corridor** -- incorporating all of the desired features and creating a sequence of events that will make the trail interesting and meet the desired level of challenge. Remember that trail quality is closely related to how well the trail builders pay attention to detail design issues.
5. **Prepare a construction plan** -- which includes input of key participants and land managers to ensure that construction techniques and equipment used are well suited for the type of trail being built. Equipment selection is particularly important in that its size and maneuverability will be reflected in the final form of the trail. For example, an intimate hiking trail is often better built with hand tools than a mechanized dozer if keeping the trail narrow with limited disruption to the surrounding landscape is important.
6. **Construct the trail** -- following the construction plan and making sure that each section of trail is stable and sustainable before moving on to the next section. Avoid exposing extensive sections of the trail to erosion during construction.
7. **Formalize a management and maintenance plan** -- to ensure that ongoing maintenance is being considered at the point when the trail is being constructed. Routine inspections are especially important during the initial season or two that the trail is open to ensure that it is stable and sustainable. Problem areas should be immediately addressed before use patterns are established and realignments become more difficult.

City of Homer
Non-Motorized Trail Planning & Design Criteria Summary
Level 3 Semi-Improved Trail

NOTE: This is a summary. Refer to Article 5.13 Non-Motorized Trails and Public Access Easements for full description of criteria.

TRAIL DESIGN CRITERIA

Trail Width & Shoulders 3 - 5 foot wide improved trail.

- 3 - 4 foot wide trail - for routes with lower volumes of traffic, and one-way or no bicycle use.
- 5 foot wide trail - for routes with moderate to high pedestrian volumes and/or two-way bicycle or equestrian uses.
- Trails should widen in areas of switchbacks, turns, steep side slopes, and as needed near structures or amenities.

Surface 4 inches NFS gravel over geotextile fabric, which may be placed over native vegetation. Alternate surfacing: porous pavement panels filled with native or imported material. Medium duty boardwalk or bridges where needed. Generally clear, with protrusions <4 inches and steps to 10 inches.

Clearance

- Vertical clearance - 8 feet minimum. Optimum 12 feet for winter and equestrian users.
- Horizontal clearance - 12 in. beyond trail edge. 24 in. from signs, trees or structures.

Grade

- Target grade < 8%, with grade reversals as needed to control erosion.
- 15% maximum for up to 50 feet.

Cross Slope of Trail

- Target cross slope - 3%, flowing to downside of tread, or to uphill side, if a drainage ditch is provided.
- Maximum - 10%

Signage

- Trail markers (as needed) to navigate winter use trails.
- Trail information signage posted at each end of the trail: Trail system map (if appropriate), trail name, length, use restrictions or accessibility warnings, and resource protection information.
- Directional signage with trail name and length, at all trail intersections.

Amenities

- Few amenities, as approved by City of Homer, such as bear proof trash receptacles, trail heads, benches for rest or viewing, interpretive signs, such as at interesting historic or natural features.

Structures

- Medium duty structures, as needed.
- Elevated plank crossing of wetlands, creeks.
- Few railings or boardwalks.
- Log, timber or rock retaining structures for cut / fill edges, as needed.

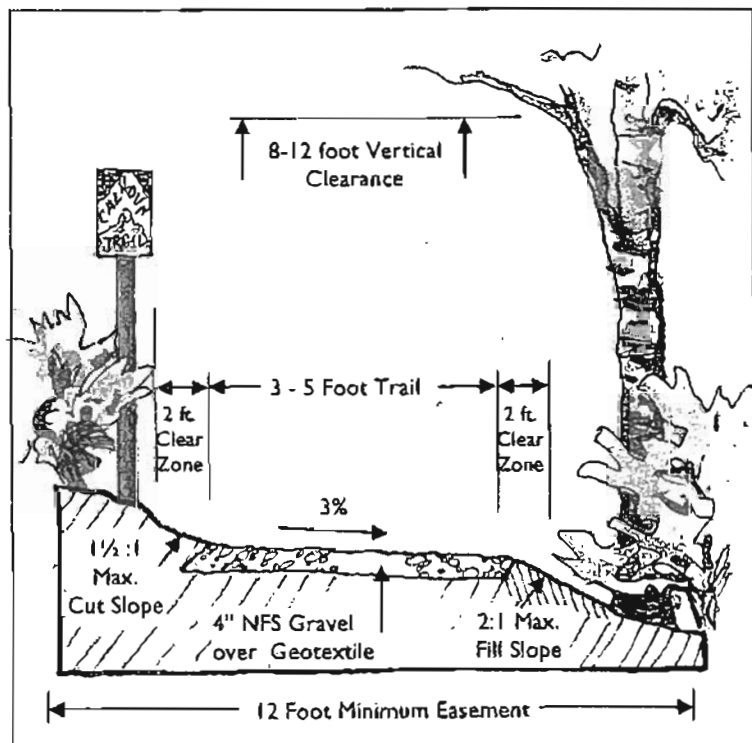

CROSS SECTION - LEVEL 3 SEMI-IMPROVED TRAIL

City of Homer
Non-Motorized Trail Planning & Design Criteria Summary
Level 4 - Fully Improved Trail

NOTE: This is a summary. Refer to Article 5.13 Non-Motorized Trails and Public Access Easements for full description of criteria.

DESIGN CRITERIA

Trail Width & Shoulders 5 - 8 foot wide paved or gravel trail.

- 5 - 6 foot wide trail - for routes with lower volumes of traffic, and fewer recreational users.
- 7 - 8 foot wide trail - for routes with bicycles and/or moderate to high user volumes.
- **PAVED TRAILS** - where a Level 5 trail is recommended, but topography or other physical conditions prevent construction to Level 5 standards, a paved Level 4 trail is acceptable. Any Level 4 trail can be paved. Provide a minimum 12 in. gravel shoulders on all paved trails.

Surface Firm and stable. Smooth, few or no obstacles. Protrusions <3 in. Steps to 8 in. Remove surface vegetation and organic soils. For gravel trails: 2 in. leveling course over 8 in. NFS gravel over geotextile. For paved trails: 2 in. AC pavement over 2 in. leveling course over 24 in. NFS gravel over geotextile. Alternate surfacing: PPP filled with native or imported material.

Clearance

- Vertical clearance - 9 feet above trail and shoulders, 12 feet for equestrian use.
- Horizontal clearance - Minimum 12 in. beyond trail edge. 24 in. from signs and trees.

Grade & Accessibility

- Accessible trails: Target grade $\leq 5\%$, 8.33% for up to 200 feet, 10% for up to 30 feet, 12.5% for up to 10 feet. No more than 30% of trail length shall exceed 8.33%.
- Maximum: 10% for up to 50 feet.
- Stairs used where absolutely necessary and pedestrians are the primary user group.

Cross Slope of Trail

- Gravel trails - 3%
- Paved trails - 2%
- Shoulders - 10% Max.

Signage

- Trail information signage posted at ends and intersections, as necessary, such as a trail system map, trail name, use restrictions, accessibility warnings, and resource protection information.
- Directional signs for nearby destinations, traffic control and warnings for intersections or other trail conditions.
- Directional signage with trail name and length, at all trail intersections.

Amenities

- Amenities common. Lighting, bear proof trash & recycling receptacles, maps, benches for rests or viewing, and interpretive signs, as approved.

Structures

- Heavy duty structures, as needed: bridges, boardwalks, retaining structures, railings.

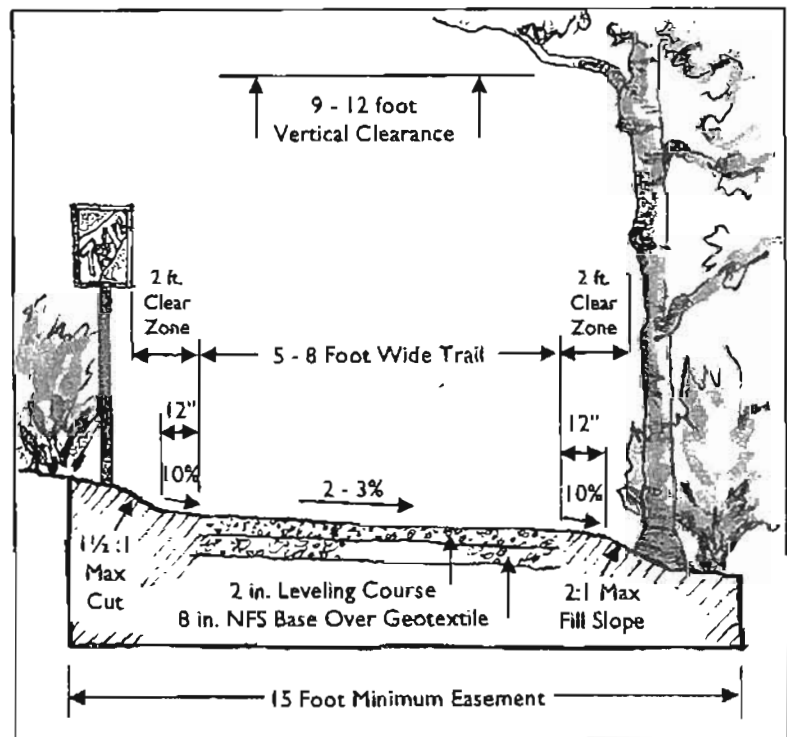

CROSS SECTION - LEVEL 4 FULLY IMPROVED TRAIL

City of Homer
Non-Motorized Trail Planning & Design Criteria Summary
Level 5 - High Use Trail

NOTE: This is a summary. Refer to Article 5.13 Non-Motorized Trails and Public Access Easements for full description of criteria.

TRAIL DESIGN CRITERIA

Trail Width & Shoulders. 8- 12 foot wide paved trail with 2 foot wide gravel shoulders.

- 8 foot Trail - for routes with lower volumes of traffic, few recreational users, or space limitations.
- 10 foot wide trail sections are the standard.
- 12 foot wide trails are recommended where traffic volumes are high, bicycles and in-line skates are common, near intersections with other trails or streets, as the trail approaches a bridge, where grades exceed 5% and handrails are provided, or near points of interest along the trail.
- **ALTERNATE TRAIL DESIGN** - Where trail is highly recreational, with bicycles, equestrians, joggers, an alternative design of 6 foot wide paved trail with 4 foot shoulders on each side or a trail with one 2 foot and one 6 foot wide shoulder is allowable. Or, provide a separated dual trail, one paved, one gravel, with a vegetated median in-between.

Surface. Uniform, firm and stable. Pavement or boardwalk. Smooth, no obstacles. Protrusions <2 inches. Construct using 2 in. AC pavement over 2 in. leveling course over 24 in. NFS gravel over geotextile fabric.

Clearance.

- Vertical clearance - 9 feet above trail and shoulders, 12 feet for equestrian use.
- Horizontal clearance - Minimum 24 inches beyond trail edge. 36 inches for posts and structures.

Grade

- Accessible Trails: Target grade $\leq 5\%$, 8.33% for up to 200 feet, 10% for up to 30 feet, 12.5% for up to 10 feet. No more than 30% of trail length shall exceed 8.33%.

Cross Slope of Trail

- Target cross slope - 2% Shoulders - 10% Max.
- Maximum, where needed for driveway crossings or other intersections - 3%

Signage

- Trail information signage posted at ends and intersections, as necessary: Trail system map (if appropriate), trail name, use restrictions or accessibility warnings, and resource protection information.
- Directional signs for nearby destinations, traffic control and warnings for intersections or other trail conditions.
- Directional signage with trail name and length, at all trail intersections.

Amenities

- Amenities common. Lighting, bear proof trash & recycling receptacles, maps, benches for rests or viewing, and interpretive signs, such as at historic or natural features.

Structures

- Heavy duty structures, as needed: bridges, boardwalks, retaining structures, railings.

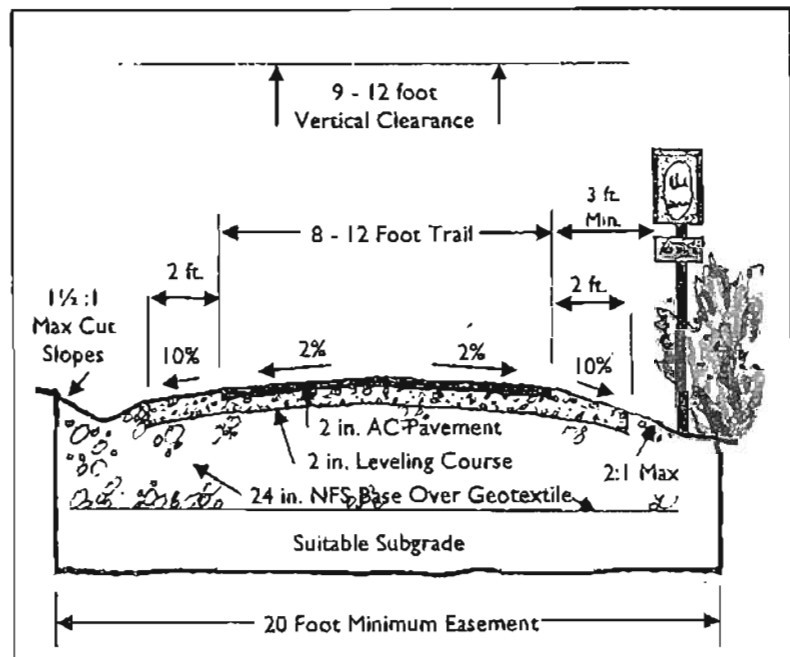

CROSS SECTION - LEVEL 5 HIGH USE TRAIL

D. TRAIL DESIGN CRITERIA

LEVEL 4: Widths can range from 5 feet to 8 feet wide. Increase widths for trails with higher volumes of traffic, or a wide mix of uses, such as equestrians, joggers, bikes, children, etc. Additional width should be provided as needed for a curve, rest areas or amenities, a passing zone, a transition to a bridge, or at intersections.

LEVEL 5: Widths can range from 8 - 12 feet wide. AASHTO recommends a minimum width of 10 feet for two-directional paved multi-use trail. Where lower volumes of traffic are expected, grades are relatively flat, and views are open, the narrower width is allowable. Wider trails are recommended for areas of high use, with frequent amenities, interruptions or intersections, busy areas with mixed land use, or frequent use by all types of users, including equestrians.

ALTERNATE. Joggers and equestrians prefer gravel surfaces. An alternative trail section may be appropriate where a wide mix of users frequent the trail. Options include an 8 foot wide paved trail with 4 foot shoulders on each side, or with one 6 ft. and one 2 ft. shoulder. A dual trail solution is another alternative for accommodating equestrians more comfortably along side a busy paved trail.

FIGURE D-6 Alternate Trail Profile.

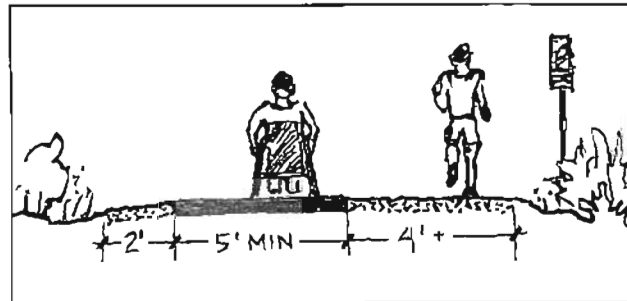

c. Shoulders

Shoulders along side a paved trail offer a transition zone along side the trail, as well as stability for the paved surface. Shoulders are typically needed along all trails, where they abut cut/fill slopes, bridges or other structures, for comfort and safety.

LEVEL 1: Typically none. On bridges, provide minimum 6 in. on each side.

LEVEL 2: Typically none. If a bridge or boardwalk is needed, an additional 2 feet of clearance on each side is recommended.

LEVEL 3: Provide 2 foot wide shoulders for crossing bridges or boardwalks, with or without railings. Provide a 12 in. shoulder between trail edge and cut / fill areas.

LEVEL 4: Provide a 2 foot wide buffer on each side on bridges or boardwalks, with or without railings. Provide 12 in. shoulders between trail edge and cut / fill areas. 2 ft. gravel shoulders required on paved trails.

LEVEL 5: Minimum 2 foot wide gravel shoulders required on all trails.

d. Passing Space

Where Level 3 trails are less than 5 feet wide, 60 x 60 in. passing spaces are required at least every 1000 feet. These areas are to be constructed adjacent to the trail, using the same construction method as the adjacent trail.



Interlocking concrete block (left) was used to harden both the approach and the drainage crossing. While not natural, it effectively controls displacement and erosion. Extensive use of concrete block is recommended only where more natural hardening methods are not feasible. Note that one of the main advantages of blocks over stones is that they interlock, creating a stronger bond.

Porous concrete block (right) hardens only the bottom of this drainage crossing on a popular mountain bike trail. The block extends well under the soil tread to eliminate any lip.



Concrete boat ramp planks. Planks laid on aggregate fill can provide lateral stability for slow water crossings. Planks are laid perpendicular to the trail.

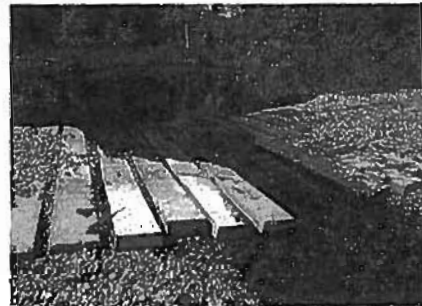

Water flow undermined small diameter aggregate under some of the planks. Larger diameter cobbles are needed as a foundation in channels with higher flow speeds.



Paved dip for ATVs. Small concrete planks have diagonally scored faces for traction. Since this is a low flow, seasonally flowing drainage, planks are set directly in native soil tread.



These crushed stone treads use poured concrete swales to prevent tread erosion by concentrated surface flows. Both trails are accessible. At left, loose stone particles have collected in the dip, partly closing it and possibly forming a slipping hazard. At right, the concrete dip is barely visible – crushed stone from the tread is. If it was used as concrete aggregate and exposed during construction, concrete color and texture exactly match the tread.

Porous Panels

Porous panels are one of the most promising emerging OHV trail-hardening systems for wetlands and sensitive areas. The panels are long lasting, low maintenance, and good at transferring lateral loads. The panels are suitable for OHV use, but a poor choice for horses and only fair for foot traffic.

The grid-like plastic panels are designed to lay on the ground surface. The bottoms of the panels have many holes to allow plants to grow through and enough strength and stiffness to be able to spread a load across the panel (or several connected panels). The top edge of the panel cells are designed to directly support traffic, but can also be ballasted or capped with soil or gravel to completely hide them.

The panels allow for wetland crossings with minimal disturbance to vegetation and the ground. They are less disruptive to vegetation than a boardwalk, which largely kills all vegetation beneath it. The panels can also be used to carry a trail over a cultural site without damaging the site.

Advantages: Panels are quite rigid, strong, and durable, yet lightweight. They can be completely removed with no remnants and no soil disturbance and can be reused elsewhere. Panels are hidden by wetland vegetation until one is near it on the trail (unlike a raised boardwalk, which can be seen from a distance).

Disadvantages: Panels are more expensive than some other surfaces. Uncapped plastic material does not look as natural as do some other hardening materials. Panels are not suitable for wheelchairs, foot traffic, or horse unless they are filled with soil or aggregate.

Installation: There are two major brands of porous panels available on the market as of this publication: GeoBlock (Presto Products, Appleton, WI) and SolGrid (SolPlastics, Montreal, Quebec, Canada). Installation of these or other suitable products should be in accordance with manufacturer specifications and instructions. In general, GeoBlock does a good job of transferring weight between rigid panels, whereas SolGrid has connectors between panel subsections that makes it more flexible. For both products, panels are screwed together to make long continuous surfaces. GeoBlock can be laid directly on top of existing soils and vegetation even in wetland areas, with vegetation growing up through holes in the panels to both anchor and hide the product. If used underwater, panels must be anchored since they will float just below the water surface if submerged. The easiest anchoring method is to fill the cells with aggregate as ballast. The panels can also be diagonally pinned into the ground with custom bent rebar or commercially available L-angled spikes. The panels tend to expand in direct sun so expansion joints are needed for continuous runs. Note that the current panels on the market can support OHMs and ATVs, but ORVs might break the joints or the screws at the joints unless they are on load-bearing soil.

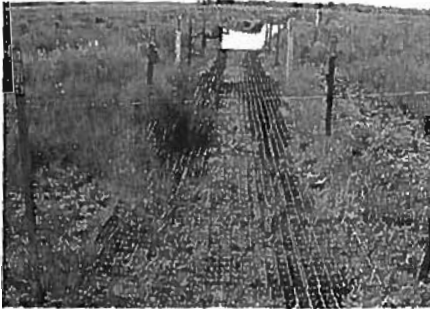

Green hardening. A major advantage of plastic porous pavement panels (top) is their ability to support vegetation. Each cell has a relatively large hole in the bottom through which vegetation can grow. This enables a drainage crossing to support plants even while serving as part of the trail.



Porous pavement panels work underwater. Ballasted with small rock, filled with soil and planted, or otherwise anchored, panels function well underwater, making them highly suitable for drainage crossings. They spread the load enough to carry vehicles, including ATVs, without sinking into the wet soil below. Unlike currently available geocell, porous pavement panels do not need to be protected from sunlight.



Hidden paneled drainage crossing. Ballasted with soil, panels can almost disappear. The top edges of the plastic cells will reappear with trail use when the top layer of soil displaces, but the tread will be laterally unified. Ruts cannot form, displacement and erosion are limited, and plants can potentially grow in the drainage channel and tread for further stabilization.

Paneled drainage crossing installation. Some panels (left) have flexible joints built in to enable them to contour to irregular treads. This photo illustrates a drainage crossing in an early stage. Grids can be left exposed or ballasted with soil or rock.

Stone Paving

Stone paving can be used for drainage crossings, trail approaches, and steep trail sections that need additional protection from erosion. Because they do not interlock, stone paving is more susceptible than concrete blocks to displacement on steep approaches.

Advantages: Stone paving is a relatively effective hardening when care is taken to fit stones together. Flat stones can be used to stabilize challenging trail sections and crossings. Stone paving also tends to be relatively low maintenance if well constructed. Stones are more visually appealing than concrete-based products.

Disadvantages: If not readily available on the site, the cost to import material is high. Stone paving is labor intensive to install and it can be a challenge to get materials to remote sites. Smooth stones may be slippery when wet. Also, stone paving installation requires excavation in a drainage way, which can be challenging to restore.

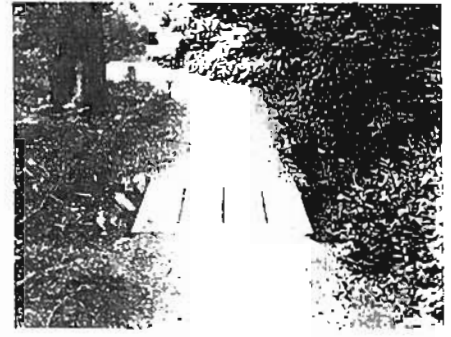
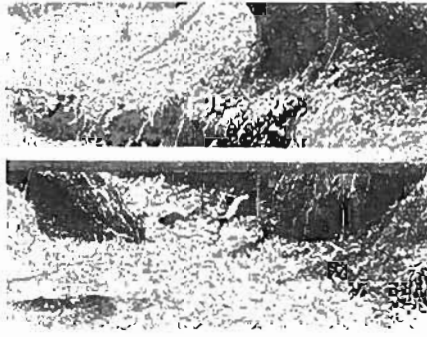
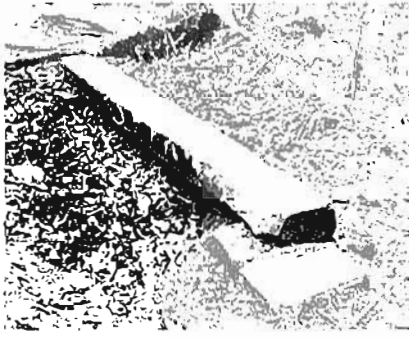

These photos highlight simple solutions to crossing drainages. Select materials based on structural integrity and site appropriateness. This is especially important on nature trails, where all built structures – even simple ones – are inherently part of the experience.



These boardwalks illustrate the range of possibilities and character. The two photos at left are associated with more remote trails where the idea is to simply get through an area without getting wet feet. This simple approach meets user expectations and there is no reason to do more. The two photos at right are associated with popular nature trails in state and regional parks, where the trail will appeal to a wider cross section of users, including those who are less ambulatory. Although more accommodating, these boardwalks still fit well into the settings.

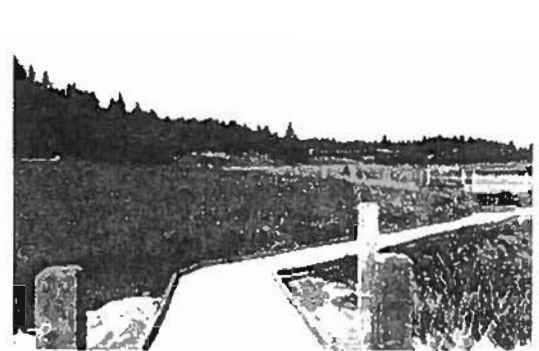
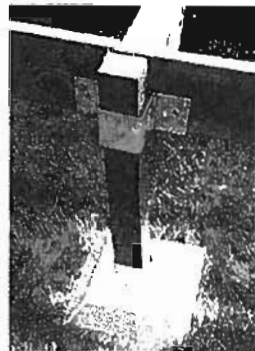
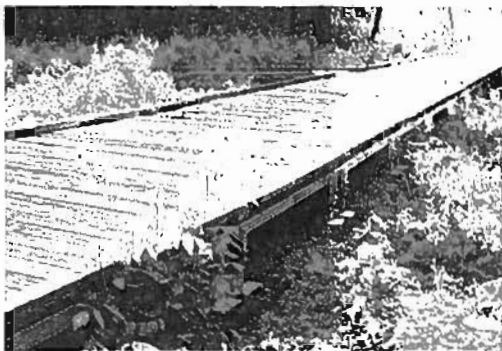

A growing number of premanufactured products are available for boardwalks and bridges. The main advantage to these products is cost and durability. As the photos illustrate, products include treated wood on steel frame (left), patented footings that require no excavation (middle), and various forms of plastic material that can be laid directly on the ground (right). Although these products have some advantages, their aesthetic qualities have to be carefully considered relative to the setting. On more remote or rustic trails, some products may be incongruent with the sense of place.

WETLAND CROSSING TECHNIQUES

The following images are from *Wetland Trail Design and Construction*, part of the *Forest Service Trails Reports 2004* collection of reports (www.fhwa.dot.gov/environment/recreails/trailpub.htm). Refer to this publication for additional information related to each the techniques shown, as well as information on a variety of other techniques and common tools.

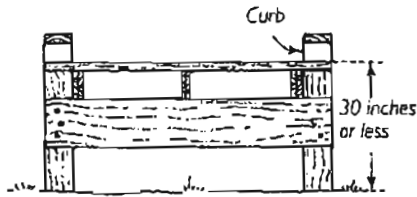

A general rule, a handrail is required whenever the deck height of a boardwalk or footbridge exceeds 30". A curb can be added to alert users of the edge of the deck and add character.

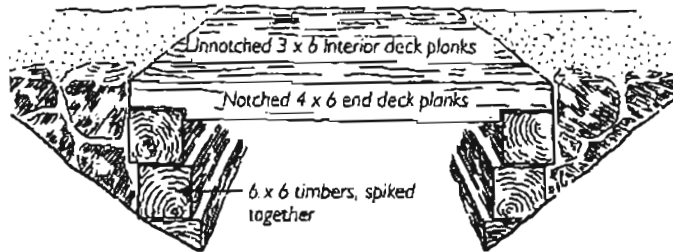

Treated timbers are occasionally used for culverts along natural surfaced trails. Notching the deck planks on both ends helps to brace the walls. Two planks with notches are adequate for a wall up to 24 inches high.

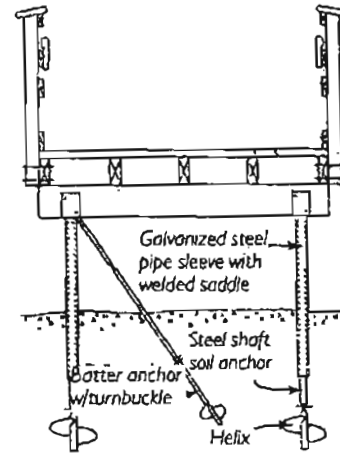
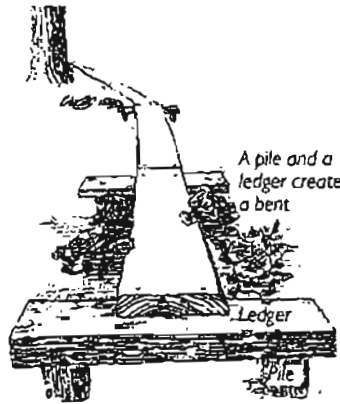
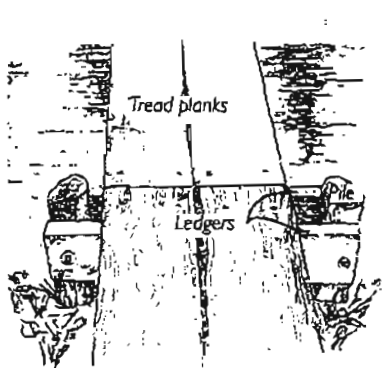

Treated timbers used as piles with either a double ledger (left) or single flat ledger (right) to support a plank tread are commonly used on rustic or remote trails where simplicity is a necessary for ease of construction.

Helical piles (screw piles) are most commonly used where soil conditions make post-hole digging difficult or where minimal grade disruption is desired. Mechanized hand tools can often be used in these instances.

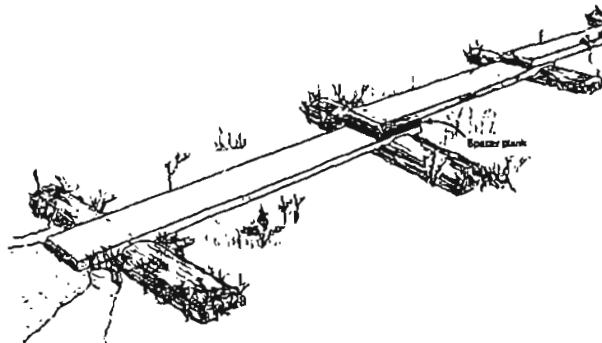
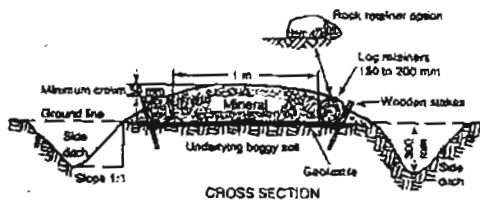
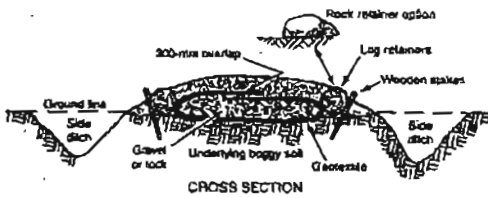

Tumpikes have also been used over the years for crossing wet areas. If this approach is used, caution must be taken to avoid blocking surface water flows or otherwise changing hydrology. If that is likely to occur, a boardwalk is recommended instead.

A simple bag bridge with sleepers is a historically common approach to crossing bogs in remote areas with readily available materials. The limitations of this approach is the sleepers will rot out over a period of years and have to be replaced, requiring more maintenance than other techniques.

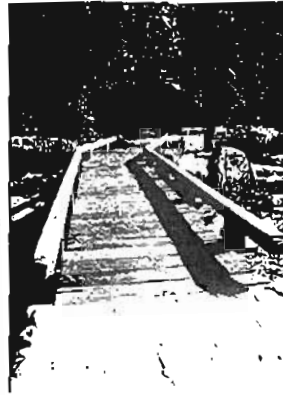
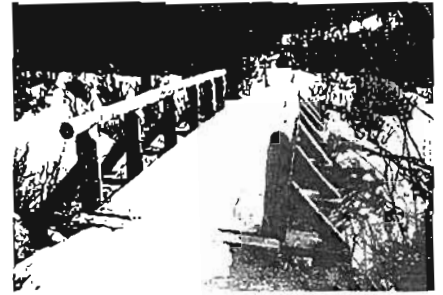

Bridges associated with natural timber, often come in many shapes and forms, as these photos illustrate. With appropriate structural integrity and aesthetic quality, bridges can add to the trail experience by making drainage crossings easier and providing a viewing platform to look up and down the flowline, which can offer some of the most diverse ecological and wildlife views along a trail.



Premanufactured bridges are becoming more popular due to improved materials, aesthetic qualities, and ease of installation. Improvements in design techniques for bridge abutments and foundation systems have also made these appealing.

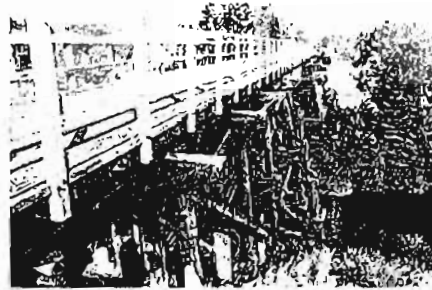

Taking advantage of abandoned rail bridges is common with natural and paved trails. Built decades ago, these bridges are often key destinations along trails, often offering expansive views.

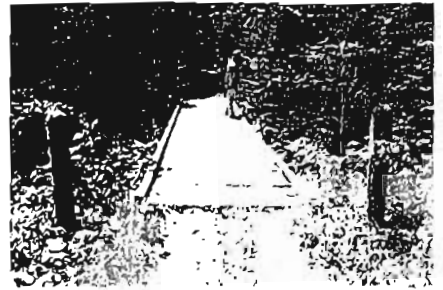

On this ATV trail, bollards are used to make sure that riders are aligned to cross this low bridge. The bollards also help protect the bridge abutment.

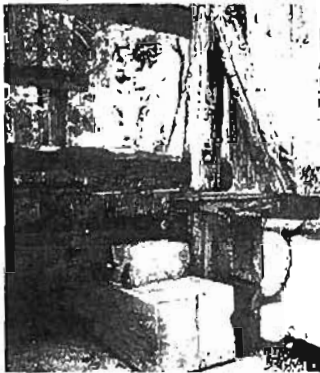

The timber sill on this stone foundation has a mortared cap. The end cap extends behind the sill to protect it from soil contact. The wide endcap and stones harden the edge and help retain the trailbed.

Bridge Foundation and Abutments

The selection of a bridge type and design is often driven by the type of foundation best suited to the site given local soils, the span of the bridge, and load-bearing requirements. In all cases, bridge foundations and abutments must be carefully considered and designed by a trained professional. The following provides an overview of common forms of bridge foundations.

Sills – require little excavation and are only used for small bridges that can move with frost heave. Thick, treated wood sills are often installed on a rocky base or gabions to provide drainage. Bridge stringers rest on top of sills and are protected from soil by a replaceable timber end cap. If a sill rots, the end of the bridge can be jacked up and the sill replaced without dismantling or replacing the entire bridge. Sills can also be used to create a level base for stringers on a bedrock or rock foundation.

Office of the City Clerk

Jo Johnson, CMC, City Clerk

Melissa Jacobsen, CMC, Deputy City Clerk II
Renee Krause, CMC, Deputy City Clerk I



491 E. Pioneer Avenue
Homer, Alaska 99603-7624
(907) 235-3130

(907) 235-8121
Extension: 2227
Extension: 2224

Fax: (907) 235-3143
Email: clerk@cl.homer.ak.us

MEMORANDUM

TO: KACHEMAK DRIVE PATH COMMITTEE
FROM: RENEE KRAUSE, CMC, DEPUTY CITY CLERK I
DATE: DECEMBER 7, 2011
RE: REQUEST TO DISCUSS AND RECOMMEND RE-FORMULATING THE
RESOLUTION ON THE KACHEMAK DRIVE PATHWAYS

Background

Committee member Beth Cumming has requested this item on the agenda under new business and recommends the committee discuss, review and redraft the resolution that city council has remanded back to the Parks and Recreation Advisory Commission prior to actually receiving it to save time and expediency.

Staff recommends that the committee keep in mind that the draft will have to go to the City Attorney prior to going to City Council again.

Recommendation

Discuss and review resolution changes the committee would like to purpose using the copy of the resolution provided on the following page. Staff requests that additions or deletions be done clearly to aid in creating the draft resolution. When possible use line numbering to aid in the added information.

**CITY OF HOMER
HOMER, ALASKA**

Lewis/Zak/Parks and Recreation
Advisory Commission

RESOLUTION 11-090

A RESOLUTION OF THE CITY COUNCIL OF HOMER,
ALASKA, SUPPORTING THE CONCEPT AND
CONSTRUCTION OF NON-MOTORIZED PATHWAYS TO
INCREASE THE SAFETY FOR MOTORIZED AND NON-
MOTORIZED USERS ALONG KACHEMAK DRIVE
LOCATED WITHIN THE CITY LIMITS, FROM THE BASE OF
THE HOMER SPTT TO EAST END ROAD.

1
2 WHEREAS, The Parks and Recreation Advisory Commission established a committee to
3 specifically address possible solutions to the hazards presented to non-motorized and motorized users
4 of Kachemak Drive; and
5

6 WHEREAS, Public input was sought through a variety of channels for solutions to address
7 these safety concerns; and recommendations to Lower the Speed Limit, Alter the Travel Lane
8 Width and Shoulder, Increase the Use of Signage, Construct Separated, Non-motorized Paths
9 paralleling Kachemak Drive using the existing Utility Easements will be contingent on available
10 funding in the future; and
11

12 WHEREAS, The Homer City Council has shown support in approval of the Homer Non-
13 Motorized Transportation and Trail Plan, Homer Area Transportation Plan, Climate Action Plan,
14 HART Policy Manual and inclusion of the Kachemak Drive Rehabilitation/Pathway on the Capital
15 Improvement Plan; and
16

17 WHEREAS, Increasing active transportation, motorized and non-motorized, offers the
18 potential for improved public health, economic development, a cleaner environment, reduced
19 transportation costs, enhanced community connections, social equity, and more livable
20 communities.
21

22 NOW, THEREFORE, BE IT RESOLVED that the City Council of Homer, Alaska,
23 hereby supports the concept and construction of non-motorized pathways along Kachemak Drive in,
24 over, and upon property within the City of Homer, and that said improvements are necessary for the
25 use and benefit of the public; and
26

27 BE IT FURTHER RESOLVED that the City Council of Homer, Alaska, further supports
28 the actions increasing the safety for motorized and non-motorized users along Kachemak Drive
29 in any or all of the following ways:

- 30 - Alteration of the existing Kachemak Drive and Shoulder
 - 31 - Separated Paths paralleling Kachemak Drive using the Utility Easements
 - 32 - Lowering the Speed Limit
 - 33 - Increasing the Use of Signage
- 34

35 PASSED AND ADOPTED by the Homer City Council this 12th day of September, 2011.

36

37

CITY OF HOMER

38

39

40

41

JAMES C. HORNADAY, MAYOR

42 ATTEST:

43

44

45

JO JOHNSON, CMC, CITY CLERK

47

48 Fiscal information: Funding not defined.

49

**CITY OF HOMER
HOMER, ALASKA**

Zak/Lewis/Parks and Recreation
Advisory Commission

RESOLUTION 11-090

A RESOLUTION OF THE CITY COUNCIL OF HOMER,
ALASKA SUPPORTING THE CONCEPT AND
CONSTRUCTION OF NON-MOTORIZED PATHWAYS TO
INCREASE THE SAFETY FOR MOTORIZED AND NON-
MOTORIZED USERS ALONG KACHEMAK DRIVE
LOCATED WITHIN THE CITY LIMITS, FROM THE BASE OF
THE HOMER SPIT TO EAST END ROAD.

1

2 WHEREAS, The Parks and Recreation Advisory Commission established a committee to
3 specifically address possible solutions to the hazards presented to non-motorized and motorized
4 users of Kachemak Drive; and

5

6 WHEREAS, Public input was sought through a variety of channels for solutions to address
7 these safety concerns; and recommendations to Lower the Speed Limit, Alter the Travel Lane
8 Width and Shoulder, Increase the Use of Signage, construct Separated, Non-motorized Paths
9 paralleling Kachemak Drive using the existing Utility Easements will be contingent on available
10 funding in the future; and

11

12 WHEREAS, The Homer City Council has shown support in approval of the Homer Non-
13 Motorized Transportation and Trail Plan, Homer Area Transportation Plan, Climate Action Plan,
14 HART Policy Manual and inclusion of the Kachemak Drive Rehabilitation/Pathway on the Capital
15 Improvement Plan; and

16

17 WHEREAS, Increasing active transportation, motorized and non-motorized, offers the
18 potential for improved public health, economic development, a cleaner environment, reduced

19 transportation costs, enhanced community connections, social equity, and more livable
20 communities.

21
22 NOW, THEREFORE, BE IT RESOLVED that the City Council of Homer, Alaska
23 hereby supports the concept and construction of non-motorized pathways along Kachemak Drive in,
24 over, and upon property within the City of Homer, and that said improvements are necessary for the
25 use and benefit of the public; and

26
27 BE IT FURTHER RESOLVED that the City Council of Homer, Alaska further supports
28 the actions increasing the safety for motorized and non-motorized users along Kachemak Drive
29 in any or all of the following ways:

- 30 - Alteration of the existing Kachemak Drive and Shoulder
- 31 - Separated Paths paralleling Kachemak Drive using the Utility Easements
- 32 - Lowering the Speed Limit
- 33 - Increasing the Use of Signage

34
35
36 PASSED AND ADOPTED by the Homer City Council this 12th day of September, 2011.

37
38 CITY OF HOMER

39
40
41
42
43
44 JAMES C. HORNADAY, MAYOR

45 ATTEST:

46
47
48
49 JO JOHNSON, CMC, CITY CLERK

50
51 Fiscal information: Funding not defined

52

Office of the City Clerk

Jo Johnson, CMC, City Clerk

Melissa Jacobsen, CMC, Deputy City Clerk II
Renee Krause, CMC, Deputy City Clerk I



491 E. Pioneer Avenue
Homer, Alaska 99603-7624
(907) 235-3130

(907) 235-8121
Extension: 2227
Extension: 2224

Fax: (907) 235-3143
Email: clerk@ci.homer.ak.us

MEMORANDUM

TO: KACHEMAK DRIVE PATH COMMITTEE
FROM: RENEE KRAUSE, CMC, DEPUTY CITY CLERK I
DATE: JANUARY 26, 2012
RE: RECOMMENDATION TO REQUEST SURPLUS PLASTIC WALKWAY
FROM PUBLIC WORKS

Background

Committee member Beth Cumming has requested this item on the agenda under new business. She has also asked to have the committee make a formal recommendation to request the Parks and Recreation Commission request the plastic walkway was that is in the possession of Public Works for possible future use in the design of the paths along Kachemak Drive.

Following is a draft memorandum from the committee to the Commission regarding the walkway.

Recommendation

Make a Motion to Recommend Parks and Recreation Advisory Commission submit a Request to City Council to have the Surplus Plastic Walkway that was salvaged from the Beluga Trail Donated for Use in Establishing the Paths Along Kachemak Drive as needed.

Office of the City Clerk

Jo Johnson, CMC, City Clerk

Melissa Jacobsen, CMC, Deputy City Clerk II
Renée Krause, CMC, Deputy City Clerk I



491 E. Pioneer Avenue
Homer, Alaska 99603-7624
(907) 235-3130

(907) 235-8121
Extension: 2227
Extension: 2224

Fax: (907) 235-3143
Email: clerk@ci.homer.ak.us

MEMORANDUM

TO: PARKS AND RECREATION ADVISORY COMMISSION
FROM: KACHEMAK DRIVE PATH COMMITTEE
DATE: DECEMBER 16, 2011
RE: CITY OWNED WALKWAY BETWEEN BUNNELL STREET AND BISHOP'S BEACH

BACKGROUND

The Committee discussed during the November 7, 2011 regular meeting re-purposing a plastic walkway that is being removed from the area between Bunnell Street and Bishop's Beach. This plastic walkway is currently used along the edge of the wetlands starting from the east end of Bunnell Street and going to Bishop's Beach.

The Committee is interested in using it to establish The Kachemak Drive Bicycle/Pedestrian Separated Path, if the City of Homer has no other plans for it.

The Committee is aware that a wooden foundation may be necessary under the plastic part and that the City of Homer may plan to keep the existing wooden foundation.

RECOMMENDATION

1. Make a motion to Approve the Recommendation to Request the Plastic Walkway Salvaged from the Bunnell Street/Bishop's Beach Walkway for possible use within the Proposed Kachemak Drive Bicycle Pedestrian Path.
2. Make a Motion to Forward a Memorandum to Carey Meyer, Director of Public Works and Walt Wrede, City Manager Recommending that the Salvaged Plastic Walkway be given to the Kachemak Drive Path Committee to be Used on the Proposed Path along Kachemak Drive at no Charge.

To: Carey Meyer
From: Parks and Recreation Advisory Commission
Subject: City-owned walkway between Bunnell Street & Bishop's Beach
November 21, 2011

Carey,

We understand that The City of Homer is planning to get rid of the plastic walkway that goes along the edge of wetlands, starting from the east end of Bunnell Street and going to Bishop's Beach . We are interested in having it to use in establishing The Kachemak Drive bicycle/pedestrian separated path, if The City has no other plans for it.

We are aware that a wooden foundation may be necessary under the plastic part and that you may plan to keep the existing wooden foundation.

Thanks for considering The Kachemak Drive Path project.

Bumpo Bremicker, Chairman, Parks & Recreation Advisory Commission

cc: Walt Wrede, Jo Johnson
Oct. 5, 2011

DEC 16 2011 AM 09:13

To: Carey Meyer
From: Parks and Recreation Advisory Commission
Subject: City-owned walkway between Bunnell Street & Bishop's Beach
November 21, 2011

Carey,

We understand that The City of Homer is planning to get rid of the plastic walkway that goes along the edge of wetlands, starting from the east end of Bunnell Street and going to Bishop's Beach . We are interested in having it to use in establishing The Kachemak Drive bicycle/pedestrian separated path, if The City has no other plans for it.

We are aware that a wooden foundation may be necessary under the plastic part and that you may plan to keep the existing wooden foundation.

Thanks for considering The Kachemak Drive Path project.

Bumppo Bremicker, Chairman, Parks & Recreation Advisory Commission

cc: Walt Wrede, Jo Johnson
Oct. 5, 2011

Office of the City Clerk

Jo Johnson, CMC, City Clerk

Melissa Jacobsen, CMC, Deputy City Clerk II
Renee Krause, CMC, Deputy City Clerk I



491 E. Pioneer Avenue
Homer, Alaska 99603-7624
(907) 235-3130

(907) 235-8121
Extension: 2227
Extension: 2224

Fax: (907) 235-3143
Email: clerk@ci.homer.ak.us

MEMORANDUM

TO: KACHEMAK DRIVE PATH COMMITTEE
FROM: RENEE KRAUSE, CMC, DEPUTY CITY CLERK I
DATE: JANUARY 26, 2012
RE: SCHEDULING ADDITIONAL MEETING DATES

Background

It is that time again to select available dates for the meetings to be held in March, April, and May. Please determine one of the following dates for each month and let me know as soon as possible to reserve it for you.

Council Chambers

March 8, 2012 Thursday
March 22, 2012 Thursday
March 29, 2012 Thursday

April 5, 2012 Thursday
April 26, 2012 Thursday

May 3, 2012 Thursday
May 24, 2012 Thursday
May 31, 2012 Thursday

Recommendation

Select a date for the next three months and forward to staff as soon as possible to enter on the Clerk's Calendar.

City of Homer
TRAIL MANUAL
Design Criteria



City of Homer Design Criteria Manual
Article 5.13

Non-Motorized Trails and Public Access Easements

Adopted: February 9, 2009

Prepared By: Casey Planning & Design and Wm. J. Nelson & Associates, Kenai, Alaska

Table of Contents

	PAGE
A. INTRODUCTION	
1. General	5
2. Codes and Regulations	6
3. Resource Information	9
B. TRAIL & EASEMENT PLANNING	
1. General	13
2. Planning and Approval Process	13
3. Submittal Requirements	14
4. Review Checklist	15
TRAIL LEVEL DESIGN PARAMETER MATRIX	16
5. Trail Selection & Planning Criteria	17
C. HOMER TRAIL TIERS - PLANNING & DESIGN CRITERIA SUMMARIES	
1. General	21
2. Description of Trail Tiers	21
LEVEL 1 Backcountry Trail	22
LEVEL 2 Recreation Corridor	24
LEVEL 3 Semi-Improved Trail	26
LEVEL 4 Fully Improved Trail	28
LEVEL 5 High Use Trail	30
D. GENERAL TRAIL DESIGN CRITERIA	
1. General	33
2. Trail Alignment	33
3. Grade & Cross Slope	37
4. Widths	40
5. Trail Construction	43
6. Structures	44
7. Wetlands, Water Crossings & Drainage	46
8. Traffic Control, Access & Safety	48
9. Amenities	49
10. Special Uses & Considerations	50

A. INTRODUCTION

I. GENERAL

This is an article of the Homer Design Criteria Manual. It is supplemental to and based upon the Homer Non-Motorized Transportation & Trails Plan (HNMTTP). Criteria in this section provides specific direction for planning and designing trails in public access easements.

The HNMTTP articulates the goals of the community regarding trails, and provides city officials and developers specific direction for creating a comprehensive network of non-motorized transportation and recreation routes in the City of Homer. It states that "by establishing a truly superb trails network that enables visitors and residents alike to travel safely and comfortably through Homer without the need for an automobile, the community will capitalize on its outdoor culture and unmatched natural setting."

a. Objectives

The intent of this article is to provide guidelines and design criteria for establishing public access easements and for designing trails within such easements. City of Homer officials will use the criteria provided in this chapter to review subdivision applications, easement proposals, and development plans for trails with public access easements. The criteria will help protect the health, safety and welfare of the public while minimizing maintenance, environmental impact, and liability concerns for the City of Homer.

Based on meeting the criteria set forth in this article, the City of Homer accepts public access easements and approved trails that are constructed within those easements. The City of Homer is responsible for maintenance of all accepted trails. The purpose of this article is to provide a uniform set of design criteria that results in trails that are planned and constructed appropriately for their location and purpose. It is also a resource for owners and designers in navigating the planning and construction process.

This article provides criteria for both the planning and design phases of a trail project. Planning criteria focuses on identifying the appropriate trail type, trail uses, location, alignment, connectivity, and access. Design criteria and guidelines address the specific design parameters and details needed to construct each trail in a manner that suits the location and use, for maximum access and minimal impacts and maintenance.

b. Applicability

Those who need to comply include:

- Subdivision projects that include a public access easement, whether it is required by Homer City Code, required or recommended in an adopted plan, or a voluntary effort by the owner;
- Projects proposing to dedicate a public access easement and construct a trail, either required or voluntary;
- Trail construction projects within already platted public access easements or within public recreation areas.

INTRODUCTION

c. How to Use This Document

Consult the Homer City Code and review the Homer Non-Motorized Transportation & Trails Plan (HNMTTP) to identify any trail requirements that apply to the property. After determining that a trail is required or desired on a piece of property, the owner, sub divider, designer, or project manager, herein referred to as the "Responsible Party", reviews the Trail & Easement Planning section of this article to understand the review process and begin to identify which trail level best fits the project. By reviewing the Trail Level Design Parameters Matrix on page 16, the Trail Level Summaries, and the Trail Selection & Planning Criteria to analyze the site, the Responsible Party should be able to select a trail level that best suits the project. Use the Trail Design Criteria to assist with fine-tuning the alignment of the easement and the design of the trail.

Developers and project designers shall adhere to the criteria in this article and the referenced documents unless compliance with such criteria is found to be unsafe or in conflict with the goals of the Design Criteria Manual or the HNMTTP, or where physical conditions restrict the ability to meet design criteria. This article gives the City of Homer Public Works Director the ability to approve alternative design solutions where required by extenuating circumstances. The Responsible Party is responsible for ensuring all trail projects meet safety standards.

d. Abbreviations and Acronyms

AASHTO	American Association of State Highway and Transportation Officials
ADA	Americans with Disabilities Act
ADAAG	Americans with Disabilities Act Accessibility Guidelines
ATBCB	U.S. Architectural and Transportation Barriers Compliance Board
ADOT&PF	Alaska Department of Transportation and Public Facilities
FHWA	Federal Highway Administration
IMBA	International Mountain Bike Association
MUTCD	Manual on Uniform Traffic Control Devices
HNMTTP	Homer Non-Motorized Transportation and Trail Plan
OHM	Ordinary High Water Mark
UFAS	Uniform Federal Accessibility Standards
USDA	United States Department of Agriculture

2. CODES AND REGULATIONS

a. Homer City Code

Homer City Code 11.04.058 Design Criteria Manual—Adopted. The City of Homer adopts by reference the "Design Criteria Manual for Streets and Storm Drainage," dated April, 1985 and revised February 1987. The "Design Criteria Manual" shall augment the standards of this chapter and shall govern site reconnaissance, survey and soils and design for streets and storm drains. (Ord. 87-6(S) 1(part), 1987).

b. ADA Accessibility Requirements and Resources

The Americans with Disabilities Act (ADA), passed by Congress in 1990, prohibits discrimination on the basis of disability. **ADA Standards for Accessible Design** (Department of Justice title III regulation 28CFR Part 36, Appendix A) are the adopted regulations, and they apply to "Places of Public Accommodation and Commercial Facilities" (private sector), "State and Local Government Facilities", and "Transportation Facilities". www.access-board.gov

Additionally, there are *design guidelines* for accessibility that are written and produced by the U.S. Architectural and Transportation Barriers Compliance Board (aka ATBCB or Access Board) that may apply to pedestrian facilities, including trails. Whether or not these are adopted by the federal government, compliance is recommended, as they represent the current thinking and may likely become the adopted standards. The City of Homer expects all trail projects to adhere to applicable standards and to most recently developed guidelines.

Accessible Trail Design. It is the responsibility of the owner (Responsible Party) to determine which standards or guidelines apply to their project. The following information may be of assistance:

ADAAG (ADA Accessibility Guidelines) 2002 These are the Access Board's accessibility guidelines, which include a combination of adopted standards and recommended guidelines. Recent (2004) supplements to ADAAG cover play areas, state and local government facilities, and some recreation facilities, such as amusement rides, fishing and boating facilities, golf courses, and sports facilities.

(DRAFT) Guidelines for Outdoor Developed Areas Additional supplements to ADAAG have been drafted by the ATBCB and (as of January 2009) but not yet approved, including guidelines for outdoor developed areas and public rights-of-way. These guidelines may apply to trail projects within the City of Homer. The federal government recognizes that not all trails can or should be constructed to be accessible, such as when it will result in irresponsible damage to the environment. Therefore, the ATBCB Guidelines for Outdoor Developed Areas include allowances and exemptions to providing accessible trails.

The design criteria for achieving "accessibility" on a *trail* is different than that for the pedestrian access routes for facilities currently required by ADA. A *trail*, as defined by the Access Board is "a route that is designed, designated, or constructed for recreational pedestrian use or provided as a pedestrian alternative to vehicular routes within a transportation system."

Accessible trails are required when connecting to accessible trail heads or to other accessible trails, elements, or spaces. Where an accessible trail is provided, the amenities along that trail must also be accessible.

The U.S. Department of Transportation Federal Highway Administration (FHWA), which oversees implementation of accessibility standards within public rights-of-way, has produced **Designing Sidewalks and Trails for Access; A Best Practices Design Guide, 2001**.

INTRODUCTION

c. Environmental Permitting

The following list is provided as a resource for project planning and may not include all information necessary for all projects. The Responsible Party shall identify and obtain all necessary permits prior to easement dedication and/or trail construction.

For multi-agency information regarding environmental permitting on the Kenai Peninsula, contact the Kenai River Center, 514 Funny River Road, Soldotna. 907-714-2478, or online at www.kenairivercenter.org. Agencies located in this office indicated with *.

U.S. Army Corps of Engineers - Administers Section 404 of the Clean Water Act; oversees permitting for projects in waters of the U.S., including wetlands. Kenai Field Office, 805 Frontage Road, Kenai 907-283-3519. Online at www.poa.usace.army.mil/reg

State of Alaska at www.state.ak.us

Department of Environmental Conservation, Division of Water. For projects requiring a National Pollutant Discharge Elimination System (NPDES) permit, such as when construction activity disturbs more than 1 acre of land. www.dec.state.ak.us/

Department of Fish and Game, Division of Wildlife Conservation. A Special Area Permit is required for many land and water use activities, including any construction activity in a designated state refuge, critical habitat area, or sanctuary. www.adfg.state.ak.us/

* Department of Fish and Game, Division of Habitat. Authorization from this agency is needed for work in designated anadromous fish streams or other fish-bearing waters.

State of Alaska Department of Natural Resources, Division of Coastal & Ocean Management. For projects within the Kenai Peninsula Coastal District.

State of Alaska Department of Natural Resources, Division of Parks and Outdoor Rec., Office of History & Archaeology. Section 106 of the National Historic Preservation Act requires review of any project funded, licensed, permitted, or assisted by the federal government for impact on significant historic properties. www.dnr.alaska.gov

* **Kenai Peninsula Borough. Coastal Management Program, Floodplain Administration, Habitat Protection**. Issues permits and/or guidance for other agency permits for projects in coastal zones, and those within 50 feet of salmon streams. For more information contact the Kenai River Center or visit www.kenairivercenter.org

City of Homer - Contact the Planning & Zoning Department to determine whether the project requires any City of Homer development permits. Construction activities, such as clearing, grading or paving, can trigger the need for such permits. www.ci.homer.ak.us/

3. RESOURCE INFORMATION

a. References and Design Resources

The following resources were used in the development of design criteria for this article, and may provide additional useful information for project designers.

United States Access Board Resources www.access-board.gov

ADA Standards for Accessible Design

ADAAG 2002 - ADA Accessibility Guidelines for Buildings and Facilities provides design standards and design guidelines for numerous facilities.

ATBCB Guidelines for Outdoor Developed Areas, 2007 (DRAFT). Includes guidelines for accessibility on trails designed for pedestrian use.

ATBCB Guidelines for Public Rights-of-Way, 2005. Includes accessibility guidelines for sidewalks and pedestrian amenities within public rights-of-way.

American Association of State Highway and Transportation Officials (AASHTO) www.transportation.org

A Policy on Geometric Design of Highways and Streets.

Guide for Planning, Design, and Operation of Pedestrian Facilities, 2004

Guide for the Development of Bicycle Facilities, 1999.

USDA Forest Service www.fs.fed.us

U.S. Department of Transportation Federal Highway Administration www.fhwa.dot.gov www.fhwa.dot.gov/environment

Designing Sidewalks and Trails for Access, Best Practices Design Guide

MUTCD (Manual of Uniform Traffic Control Devices)

Wetland Trail Design and Construction

Equestrian Design Guidebook for Trails, Trailheads, and Campgrounds

Trail Construction and Maintenance Handbook

Rails-to-Trails Conservancy www.railstotrails.org

Trails for the Twenty-First Century

International Mountain Bike Association IMBA www.imba.com

Alaska Trails www.alaska-trails.org

INTRODUCTION

b. Definitions

ACCESSIBLE TRAIL - A trail designed for use by pedestrians which is constructed to meet the accessibility criteria established by ATBCB for trails in outdoor developed areas with respect to grades, cross-slope, amenities, and surfacing.

BICYCLE - A vehicle propelled solely by human power upon which a person may ride, having two, three or four wheels.

CROSS SLOPE - The slope measured perpendicular to the direction of travel. For the purposes of this article, cross-slope refers to the trail itself, versus the general side slope of the natural terrain upon which the trail is constructed.

FILL - Material placed above the original or natural ground lines.

FULL BENCH TRAIL - A trail constructed on a cut slope. No part of the trail is built over fill material.

GEOTEXTILE - See current edition of Homer Standard Construction Specifications.

GRADE - The slope parallel to the direction of travel, measured in percent. For example, a 1 foot change in vertical elevation on a 50 foot long section of trail has a 2% grade.

GRADE REVERSAL - A change in the direction of the running grade along a trail, from uphill, to downhill, and vice versa. Used to control erosion.

HALF RULE - A general rule used when determining the grade of a trail on a hillside. The trail grade should be no more than half the side slope grade.

INTERSECTION - Area where two or more trails or roadways meet or cross.

MEAN (ORDINARY) HIGH WATER MARK - A line on the shore established by the fluctuations of water and indicated by physical characteristics such as clear, natural line impressed on the bank, shelving, changes in the character of soil, destruction of terrestrial vegetation, the presence of litter and debris, or other appropriate means that consider the characteristics of the surrounding areas.

MULTI-USE TRAIL - A trail designed for more than one type of user, or use, such as bicycles and pedestrians, or for transportation and recreation.

NFS (Non Frost Susceptible) - A classification for soil that is not as likely to be affected by seasonal freezing and thawing. Nonorganic soil containing less than three percent (3%) by weight, of grains smaller than .02mm obtained from minus three inch (3 in.) material.

NON-MOTORIZED - Trail recreation by modes such as bicycle, pedestrian, equestrian, skate, or ski. May include electric wheelchairs.

OBSTACLE - A physical object that limits the horizontal or vertical passage space, by protruding into the circulation route and reducing the clearance width of a trail.

INTRODUCTION

PAVEMENT - Surfacing constructed with asphaltic concrete (AC), Portland cement concrete (PCC) or dry laid concrete pavers.

PASSING SPACE - A widened section along a trail to allow for two users to more comfortably or safely pass one another.

PEDESTRIAN - A person on foot or who is using an assistive device, such as a wheelchair, for mobility. Pedestrians, for the purpose of this document, may include those using electrically powered mobility devices.

PPP (POROUS PAVEMENT PANELS such as GeoBlock or EcoGrid) - Porous pavement panels are three-dimensional, structural hi-density polyethylene panels designed to provide a durable wear surface and load distribution system.

PUNCHEON - Short-span footbridges or a series of short-span footbridges supported by sleepers.

RAMP - A sloped transition between two elevation levels. In reference to ADA accessibility, a portion of an accessible pedestrian walkway with a running grade $>5\% \leq 8.33\%$, for a maximum rise of 30 inches.

RESPONSIBLE PARTY - The property owner, either private or public.

SIDE SLOPE - Existing cross-slope of the natural terrain.

SIGHT DISTANCE - the length of a roadway visible to a trail user; the distance a person can see along an unobstructed line of sight.

SHOULDER - The area directly adjacent to either side of the trail surface.

TRAIL - As used in this article, a trail is a path or route identified and/or constructed for the purpose of non-motorized recreation and/or transportation. It may be located within an public access easement or right-of-way, or on public property.

TRAIL PROFILE - An elevation or cross-section through a trail easement, showing the proposed design of the trail and adjacent

TRAIL SEGMENT - That portion of a trail that lies between two intersections or destinations and is consistent in its design and use for it's entire length. Most trails are composed of multiple trail segments.

TRAIL SPUR - A short segment of trail that leads off a trail and connects the user to a nearby point of interest, such as an overlook, restroom, or picnic area.

TRIP GENERATOR - Any origin or destination that a trail user may be traveling to or from, including public facilities, residential or commercial areas, or another trail.

UNDERDRAIN - Drainage technique for allowing water to flow under the tread of low use, rustic trails, such as Level 1 or 2 trails.

VERTICAL CLEARANCE - Minimum unobstructed vertical passage space required along a sidewalk or trail.

B. TRAIL & EASEMENT PLANNING

I. GENERAL

This section provides guidelines for the planning of public access easements and non-motorized trails within and near the City of Homer. The criteria established in this section also provides the basis for review and approval by the City of Homer, prior to accepting public access easements or constructed trails. Proposed easements or trails that are in conflict with this article, the HNMTTP, the Homer Comprehensive Plan, or any other adopted plans, will not be approved.

The purpose is to ensure that access easements and trails are planned and designed to result in a cohesive network of safe, enjoyable, low maintenance trails that blend with the varied landscapes of Homer and offer year round transportation and recreation opportunities for the citizens and visitors of Homer.

2. PLANNING & APPROVAL PROCESS

The following is an outline of steps that the Responsible Party may need to follow to dedicate public access easements or to construct trails on public property or within public access easements or rights-of-way. This process may vary depending on the individual circumstances of each development project.

Table B-1 Outline of the Planning & Approval Process

PLANNING PHASE I Preliminary Plat or Easement Dedication
<ul style="list-style-type: none"> - Research and Analysis - The Responsible Party reviews adopted plans and ordinances for any trail requirements or recommendations, conducts site analysis, and uses Trail Planning Criteria to begin to identify an appropriate trail level, location, alignment and use. - Discuss the trail project with the City of Homer Planning & Public Works Departments, and environmental permitting agencies to identify Issues and adjust the trail proposal. - Conduct preliminary engineering as necessary to fine-tune the trail level, location and alignment. Develop a trail plan & profile, typical sections, and cross-sections at 50 foot intervals, or as required by Public Works. - Submit a preliminary plat application or a proposal for easement dedication, based on the planning criteria of this chapter, to the City of Homer Planning Department. See following page for submittal requirements.
PLANNING PHASE II Final Plat, Easement Dedication, or Subdivision Agreement
<ul style="list-style-type: none"> - Field locate and survey the final trail alignment as necessary to ensure it meets planning and design criteria. - Obtain environmental permits. - Submit final plat or easement dedication to City of Homer Planning Department.
CONSTRUCTION PHASE Subdivision Agreement or Construction Permit
<ul style="list-style-type: none"> - Submit trail construction documents to the City of Homer Department of Public Works for review and approval. - Trail construction. - City of Homer inspection of the constructed trail.

B. TRAIL & EASEMENT PLANNING

3. SUBMITTAL REQUIREMENTS

Refer to Table B-2 for a list of the information that is required during the planning and approval process for trail easement and trail construction projects.

Table B-2 Submittal Requirements

PLANNING PHASE Preliminary Plat or Easement Dedication
<p>Project Narrative. A written description of the proposed project including:</p> <ul style="list-style-type: none"> - How the proposed trail is consistent with adopted plans; - Proposed Trail Level, easement width, trail width, running grades, amenities or structures; - The intended and expected transportation and recreational uses for the trail or for each segment of the proposed trail, and any foreseen challenges or opportunities; - Existing and future land use of the project area, including trails, structures, features, as well as any designated areas of preservation; - Character of surrounding areas, including land use type and density; - How and where the trail will connect to public areas or adjacent destinations; - Natural features and how the project will incorporate or work around them, such as topography, vegetation, rocks, beach, wetland, and creeks, as well as views into or beyond the project area; - Explanation as needed to justify a proposed trail that does not conform to adopted plans and ordinances, does not meet design criteria standards, or involves any special user conflicts or construction challenges. <p>Project Maps, Drawings, Information. Submit scaled plan drawings and/or maps with the following information. All sheets are required to illustrate the location of the proposed trail or easement.</p> <ul style="list-style-type: none"> - Context: Large scale map of the project area as it relates to surrounding areas. Identify all existing trails, easements, roads, public facilities, water bodies, natural features, land uses, and any other relevant features in and around the project area; - Topographic contours at 2 foot intervals; - Trail Route - identify the width, location and general alignment of the proposed easement on all plan views provided. Include locations of any existing trails or trails identified in any adopted plans, as well as proposed trail heads, amenities, points of interest; - Trail profile along the length of the trail, illustrating preliminary grades along the trail route; - Typical section of the trail, and cross-sections at intervals of 50 feet, or as required by the Department of Public Works. Identify existing and proposed slope across easement, proposed cut and fill requirements; - Wetlands, rivers, or other water bodies and all setbacks or areas with developmental restrictions; - Soils Information, mapped. For Level 1,2 & 3 trails: Conduct a field assessment, consult wetland maps to determine potential for saturated soils, post hole to 12 in. deep. For Level 4 & 5 trails: Soil boring to 4 ft .minimum and provide soils report as per Article 5.1.c. or as required by Public Works; - Vegetation - general vegetation areas; uplands, wetlands, pasture, etc.; - Site Analysis- show views into, beyond, or within the site, and land use conflicts or opportunities.
PLANNING PHASE II Final Plat or Easement Dedication
<ul style="list-style-type: none"> - Revised plat and updated project narrative, maps and drawings; - Environmental permits; - Any other information required by City of Homer Planning or Public Works Departments.
CONSTRUCTION PHASE Subdivision Agreement or Construction Permit
<p>Submit the following to the Department of Public Works for a Subdivision Agreement or Construction Agreement:</p> <ul style="list-style-type: none"> - Final plat or easement dedication and environmental permits; - Construction drawings.

B. TRAIL & EASEMENT PLANNING

4. REVIEW CHECKLIST

a. Planning Phase.

The following is a review checklist for the City of Homer to assess a proposed trail route or access easement:

- Conforms to all required and/or recommended trail routes for the project area, as found in Homer City Code and adopted plans. If not, there are justified reasons for deviation, such as: safety, excessive impact to surrounding area, land use conflict.
- All necessary environmental permits have been obtained. If not, demonstrates the permitting process is sufficiently underway with respect to the timeline of the trail project.
- Addresses any need for upgrading, re-locating or preserving of existing trail routes that do not meet the intent or design criteria of this article.
- The proposed trail level is appropriate for the existing land use and anticipated user groups and user volumes.
- Easement width meets minimum design criteria and is adequate to accommodate turns, structures, amenities and trail maintenance for the proposed trail.
- Proposed trail or easement route meets all planning and/or design criteria for the proposed trail level and uses, including:
 - Connectivity - compliments existing trails or walkways, provides logical and safe alignments, connections, and intersections;
 - Horizontal Alignment - safe and comfortable curves and sight distances, addresses views and slopes;
 - Design Fits Existing Conditions - Running grade, cut-fill, stairs, retaining structures, drainage, soils;
 - Minimizing Water Crossings - streams and wetlands;
- Maintenance Considerations - Proposed trail meets planning and design criteria while minimizing the use of structures.

b. Construction Phase.

The following is a review checklist for trail design / construction approval.

- Plans provide for appropriate level of trail hardening or surfacing, signage, amenities, structures, or other features as appropriate or necessary for the location and use.
- The trail design is consistent in its accessibility level, design and use throughout the entire length of the trail. If not, individual segments are consistent.
- Trail design is consistent with what was approved in the planning process.
- The trail design meets the minimum design criteria for the designated trail level and for the anticipated user groups.

TRAIL LEVEL DESIGN PARAMETERS

	LEVEL 1 Backcountry	LEVEL 2 Recreation Corridor	LEVEL 3 Semi-improved Trail	LEVEL 4 Fully Improved Trail	LEVEL 5 High Use Trail
Description and Application	A simple, narrow, potentially rugged natural surface trail primarily for recreation. Moderate skill needed, with steeper slopes, light curves, and obstructions common. Users may include hiking, snow-shoeing, skiing, equestrian, mountain biking. User volumes are very light.	An unimproved, informal, wide, flat or gently sloping natural surfaced trail corridor for single or multi-use recreation in rural or semi-rural areas or within public parks or recreation areas. Users may include hiking, snow-shoeing, skiing, mountain biking. User volumes are very light to moderate, depending on the use.	An informal trail through semi-urban to rural areas, used for access between neighborhoods and destinations, or for recreation. Accessibility may be limited. Use is primarily pedestrian, but may include bicycling, equestrian, snow-shoeing, skiing. User volumes light to moderate.	A wide multi-use trail with a firm surface meeting ADA accessibility standards for recreation trails. A transportation and recreational route through the developed areas of Homer and within residential neighborhoods. May accommodate occasional equestrians. User volumes moderate to heavy.	A wide, accessible paved trail that accommodates a wide variety of non-motorized users. These multi-use trails provide access between public spaces, sidewalks, civic & cultural buildings and other major destinations within the core civic and commercial areas of Homer. Two-way multi-use trail for pedestrians, in-line skates, bicycles. May be designed for equestrians. Heavy use.
Widths					
Easement	8 feet	20 feet	12 feet	15 feet	20 feet
Trail	6 - 24 inches	6 - 16 feet, depending on terrain and managed use	3 - 5 feet, depending on bicycle use	5 - 8 feet	8 - 12 feet, depending on user volumes.
Shoulders	None	None	None	12 in. for paved routes	24 in.
Surface					
Material/Type	Native materials. Plants, rocks, PPP or other turf reinforcement materials. Limited grading.	Native earth, ground cover and/or seeding. Boardwalk or turf reinforcement materials. Limited grading.	4 in. NFS gravel over geotextile. Boardwalk, PPP or other turf reinforcement materials.	Firm and stable, NFS gravel over geotextile. Paving optional. Boardwalk.	Uniform, firm and stable. Paved trail or boardwalk.
Obstacles	Roots, rocks, and log protrusions to 6 in., steps to 14 inches	Generally clear. Protrusions <6 in. No steps.	Generally clear. Protrusions < 4 in. Steps discouraged.	Few or no obstacles, protrusions 2-3 in., Steps discouraged	Smooth, no obstacles. Protrusions < 2 in. Steps discouraged.
Structures	Minimal, rustic structures	Typically unimproved with no structures	Medium duty boardwalks and retaining structures	Bridges, railings, retaining walls.	Bridges, railings, retaining wall.
Clearance					
Vertical	6 ft. hiking, 8 ft. bicycle & equestrian, 10 ft. snowshoeing	12 feet	8 feet ; 12 feet for winter and equestrian use	9 feet; 12 feet for equestrian use	9 feet; 12 feet for equestrian use
Horizontal	36 in. with minimal encroachment	8 - 20 feet wide, depending on managed use	12 in. beyond tread, 24 in. for trees, signs, structures	12 in. beyond tread, 24 in. for trees, signs, structures	24 in. beyond tread, 36 in. for signs, trees, structures
Grade					
Target	< 12%	< 10%	< 8%	< 8%	< 5%
Maximum	30%, for <30 feet	15% for < 50 feet	For Level 5 and other accessible trails: 5% for any length, 8.33% for up to 200 feet, 10% for up to 30 feet, 12.5% for up to 10 feet. No more than 30% of trail length shall exceed 8.33%. Otherwise: Level 3 = Max 15% for up to 50 feet, Level 4 = Max 10% for up to 50 feet.		
Cross Slope					
Target	3 - 10%	5%	3%	2%	2%
Max	Up to natural side-slope; 10% for bicycle use	10%	10%	3%	3%, at driveway crossings

B. TRAIL & EASEMENT PLANNING

5. TRAIL SELECTION & PLANNING CRITERIA

This section provides guidance and planning criteria for selecting the appropriate trail location, level, use and alignment for the project location. The criteria will help ensure that all trails are constructed to provide safe and convenient routes between destinations, improve the continuity and connectivity of the whole trail network, meet the needs of all users, minimize impacts to surrounding areas, and utilize construction methods that are economical and will result in long lasting, low maintenance trail facilities.

The Responsible Party should be prepared to discuss how the proposed easement and/or trail will meet the intent and requirements of this article, and how it will mitigate any specific challenges encountered with the project. Refer to Design Criteria section (pages 33-49) for additional trail design criteria.

a. Codes, Regulations and Plans

All proposed development projects are required to provide trails and easements where they are required by Homer City Code, the HNMTTP, the Homer Comprehensive Plan, the Town Center Plan, and other adopted plans. All proposed trails within the City of Homer shall be in accordance with the standards of this manual and meet the intent of the HNMTTP, and any other plans adopted by the City of Homer. If a proposed trail is not in accordance with plans and ordinances, submit sufficient explanation and support data to justify an alternative design solution.

The HNMTTP identifies locations of existing, proposed, and recommended trail corridors, and provides direction to community leaders and developers for the development of a functional network of trails. It represents the latest cooperative effort by the community to identify the future direction of Homer's trail system. Use this document for direction when planning for new trails or when reconstructing or relocating existing trails.

b. User Volumes and Types

The design of a trail must accommodate the use of the trail. It is easier to build a trail to suit the anticipated users than to control the users to match the design of the trail. For this reason, it is important to carefully research and analyze the project area to determine the anticipated volume and types of users. Generally, high volumes and wide ranges of user groups warrant wider, more developed trails with shorter segments between destinations and more signage and amenities. Some recreational uses require specialized design solutions. For further assistance, refer to D. Trail Design Criteria.

i) **User Volumes.** Consider the following when establishing the anticipated volumes:

- How many destinations or trip generators within 1/4 mile of the trail corridor, including other trails.
- If the trail connects to any large volume trip generators, such as a school, a visitor's center, a library, a popular recreation area, or a busy commercial area, such as the Spit, or Pioneer Avenue;
- If the trail provides multiple connections to nearby trails or destinations.

B. TRAIL & EASEMENT PLANNING

ii) **Use Types.** Land use, existing and future (planned), establishes the basis for the type of trail users. Understanding the range and types of users that will use the trail is a critical component guiding the design of the trail.

Recreational Use. Trail conditions that attract recreational users:

- Connects to recreation destinations;
- Offers a scenic, or otherwise interesting route;
- Specially located and designed for a particular recreational use or event;
- Long routes, with few intersections or interruptions, especially loop trails;
- Wide, paved trails are attractive to in-line skaters and young families.

Transportation use. Trail conditions that serve transportation needs:

- Direct routes between destinations and trip generators;
- Few user conflicts;
- Frequent and convenient connections between trails, streets, sidewalks, parking areas and destinations;
- Safe and accessible trail routes and conditions.

Mixed Use. Trail conditions that attract a wide mix of user groups, including pedestrians, bicycles, in-line skates, strollers, wheelchairs, and children tend to require more width, structure, signage, and amenities:

- Paved trails;
- Trails that connect to a variety of generators, such as the Senior Center, a grocery store, a park, the library, a trailhead, and a neighborhood;
- Trails that provide access to a variety of destinations as well as an interesting and enjoyable route.

c. History, Access, & Connectivity

Each new trail segment improves the continuity and connectivity of Homer's trail network. Proposed trail easements are required to meet the following criteria:

- It is as accessible as possible, within reason;
- It connects to other nearby trails, where safe, reasonable and appropriate;
- Existing trails are not removed or disrupted. They are upgraded, relocated or realigned to ensure they meet the planning and design criteria of this article;
- The trail is continuous and provides for the same design, use and level of accessibility for each segment;
- The trail provides a logical connection between publicly accessible destinations for all trail users. Dead end trail segments are not allowed unless it is shown that there are plans for continuation of the trail in the near future;
- Provide trail heads and/or parking, as needed;
- Trails with higher use volumes and a wide variety of user groups are high level trails, such as Level 4 or 5;
- Lower level trails and those of lesser accessibility and limited uses are in locations with physical constraints, low user volumes, or where the trail segment is not providing a transportation link between generators and destinations;
- A trail segment that connects two other trails is designed to the same level as the other trails;
- Intersections are located and aligned to provide for adequate site stopping distances, maximum safety, and logical connections between destinations;

B. TRAIL & EASEMENT PLANNING

- Trails provide options and alternatives and avoid conflict or confusion;
- Where trails begin or end at another trail, those of lesser accessibility or more restrictive uses shall branch from those of higher level of accessibility, so as not to trap or inconvenience a trail user.

d. Topography & Natural Features

A well designed trail feels natural, tends to flow with the natural landscape, avoids steep climbs and unnecessary exposure to water, and endures over time with little maintenance. Existing conditions, such as slopes, water, soils, vegetation, roads and structures, all affect the planning and design of trails.

i) Objectives. The three primary objectives relating to trail alignment and terrain:

- Access - Providing a trail that is as safe and as accessible as possible.
- Environmental Impacts and Maintenance - Minimizing contact with hydric soils and surface water, either flowing across or along the trail.
- Experience - Creating an interesting and enjoyable trail experience.

ii) Criteria

1. Select a trail level that suits the landscape and align it to fit the terrain meet the design criteria for the trail's use;
2. Trail alignment should provide the most accessibility with the least impact to surroundings;
3. Avoid long segments where the trail travels only up or downhill. Provide grade reversals as needed to meet trail design criteria for water and erosion management;
4. Avoid excessive costs and engineering, (cut, fill, or structures) to make a particular trail design fit into the landscape. Balance costs and benefits to suit the trail location and use;
5. Locate trail or easement to avoid or minimize water crossings (creeks, seeps, wetlands). Re-route existing trails where practical;
6. Avoid intersections on curves or with maximum running grades.
7. Avoid stairs where possible, especially on multi-use trails;
8. Refer to Homer City Code Title 21 for steep slope requirements;
9. Align trail to minimize switchbacks, avoid problem soils, and protect existing natural features;
10. Align trail to take advantage of natural features and views, and to provide a variety of experiences.

e. Costs—Budget Planning

Construction costs should align with the trail level and the volume and type of use. Higher Trail Levels are inherently more expensive to construct and maintain. Balance trail priority, use, cost and benefit for the location and purpose of the trail.

Proper trail selection and design should minimize maintenance. Specialized use trails, such as groomed ski trails and equestrian trails may require more maintenance, as do those that interface with water, such as bridges or boardwalks.

C. HOMER TRAIL TIERS

I. GENERAL

The City of Homer's goals are to have non-motorized recreation trails and transportation corridors that provide a range of accessibility and experience for many types of users throughout the year.

This trail tier system is intended to provide for a logical hierarchy of public trails for access and recreation throughout the diverse developments and landscapes of Homer. Planning and design criteria are provided for each of the five standard trail types addressed in this chapter.

The objective is to have planning and design criteria that will result in trails that are planned and constructed appropriately for their purpose and their location. All trails will provide for maximum access for their users with minimum impacts and maintenance.

This section is intended to provide a brief overview of the planning and design criteria for each of the five (5) TRAIL LEVELS. These summaries are a starting point for the planning of an easement, and the design of a trail. The Responsible Party should refer to all applicable criteria in this Chapter and to the referenced resources, as needed, to plan and develop a trail that meets the City of Homer's objectives for a non-motorized transportation and trail system.

These trail levels should be applicable to most trail projects. If an alternative trail design is necessary, it should be as consistent as possible with the Forest Service trail design parameters and the criteria of this article. The City of Homer Public Works Director has the authority to accept alternate trail design solutions.

2. DESCRIPTION OF TRAIL TIERS

The trail matrix is a set of five (5) trail levels, with varying accessibility, widths, applicability, character and use. This section provides a two-page summary of planning criteria, design parameters, and a typical cross section for each trail level. The summaries are not intended to stand alone as the design criteria for any trail. The Responsible Party should consult all applicable criteria sections of this article when designing a specific trail.

- a. **Level 1 - Backcountry Trail.** For rural areas, rugged terrain and very low recreational use situations.
- b. **Level 2 - Recreation Corridor.** A basically unimproved natural terrain corridor primarily for groomed ski trails or low use, casual recreation routes, with little or no visible tread area.
- c. **Level 3 - Semi-Improved Trail.** A medium sized, constructed gravel trail, with limited accessibility, intended for a mix of recreational and transportation uses.
- d. **Level 4 - Fully Improved Trail.** A wide, accessible gravel or paved trail for medium to high use areas.
- e. **Level 5 - High Use Trail.** A wide paved, accessible trail, with amenities and structures for a mix of transportation and recreational uses.

City of Homer
Non-Motorized Trail Planning & Design Criteria Summary
Level 1 - Backcountry

NOTE: This is a summary. Refer to Article 5.13 Non-Motorized Trails and Public Access Easements for full description of criteria.

PLANNING CRITERIA

Location

- Rural, remote or lightly traveled recreational trails, typically in residential or undeveloped areas where a higher level trail is not feasible or appropriate.
- Branching off a higher level trail, with loops or connections to public access areas.
- Historic hiking routes through more remote areas, steep or rugged terrain. Alignment may change, as needed to meet design criteria.
- Connects to recreation destinations such as overlooks, trail heads, camping areas, and parks.

Use Recreational trail for very light volumes of traffic. May be designed and maintained for hiking, mountain biking, snow-shoeing, or equestrians.

Easement Width 8 feet minimum. More as needed to accommodate switchbacks, slopes, and trail maintenance operations.

Trail Maintenance. Cut vegetation within clearance zones, and provide repairs or upgrades to trail surface, water crossings, signage and other amenities or structures, as needed, and as funding allows.

Topography Terrain can be quite varied, including flats or steep slopes, rocky, wet, wooded, or open. Topography must allow for a trail alignment that meets design criteria with little or no structures, cut or fill.

Alignment Level 1 trails are primarily recreation routes through semi-rural to remote areas. They connect neighborhoods, parks, trailheads, and other recreation destinations.

- The alignment of the easement must be finalized in the field, to ensure a feasible route that meets the objectives and the trail design criteria, and which utilizes existing features that will enhance the user's experience;
- Re-align any problematic portions of an existing trail as needed to provide a safe and sustainable trail route;
- Refer to IMBA "Trail Solutions" and USDA Forest Service Trails Management Handbook and "Trail Construction and Maintenance Notebook" - resources for planning and building Level 1 trails;
- Take advantage of natural features by meandering trail to align views, wrap around rocks or other features, and generally follow the natural flow of the terrain;
- Provide switchbacks as needed to meet design criteria;
- Erosion Control Criteria:
 - Follow the *half rule* as developed by IMBA; trail grade should be no more than 1/2 the side slope grade.
 - Align trail to follow natural dips in the terrain, or to create dips (grade reversals) along the trail, every 20-50 feet. These prevent water from flowing along, and eroding, the trail. They also enhance the trail experience.

Soils, Water & Hydrology Saturated soils are highly susceptible to erosion. Avoid seeps and other areas with saturated soils. Minimize the crossing of creeks, rivers and wetlands, which is more expensive to build and more difficult to maintain.



Level 1 Trail Description

A simple, narrow, potentially rugged natural trail primarily for recreation. Moderate skill needed, with steeper slopes, tight curves, and obstacles common.

City of Homer Non-Motorized Trail Planning & Design Criteria Summary Level 1 - Backcountry

NOTE: This is a summary. Refer to Article 5.13 Non-Motorized Trails and Public Access Easements for full description of criteria.

TRAIL DESIGN CRITERIA

Trail Width & Shoulders. 6 - 24 inch wide tread on native soil, or boardwalk. No shoulder necessary.

Surface. Native, with limited grading. Rock, soil, or wood where needed to cross wet areas. Roots, rocks and log protrusions to 6 inch, steps to 14 inches.

Clearance.

- Vertical clearance - 6 feet for hiking, 8 feet for bicycle, 10 feet for equestrian and snowshoeing.
- Horizontal clearance - Minimum 36 in. width.

Grade

- Target grade <12%, with grade reversals every 20-50 feet.
- Maximum 20% for trails where underlying soils are sand, silt, or clay. 20%- 30% for gravel or rock base.
- For grades over 30%, natural trail base and surface should be composed of angular rock, large rock or solid rock. Use steps to minimize erosion and steep grades.

Cross Slope of Trail

- Target cross slope - 3-10%. Flowing toward the down hill side of the tread.
- Maximum - up to natural side slope, 10% for bicycles.

Signage

- Trail markers, as needed, to navigate trail year round.
- Resource protection information and trail identification signs including trail name, length, and any use restrictions or accessibility warnings posted at each end of the trail.
- Directional signage with trail name and length, at all trail intersections.

Amenities

- Trail head, with parking and trail signage.

Structures

- Minimal use of structures. Rustic plank with sleeper logs typical for low volume water crossings. Porous pavement panels or underdrains for short wet crossings.
- Steps constructed with on-site material such as rocks and logs.

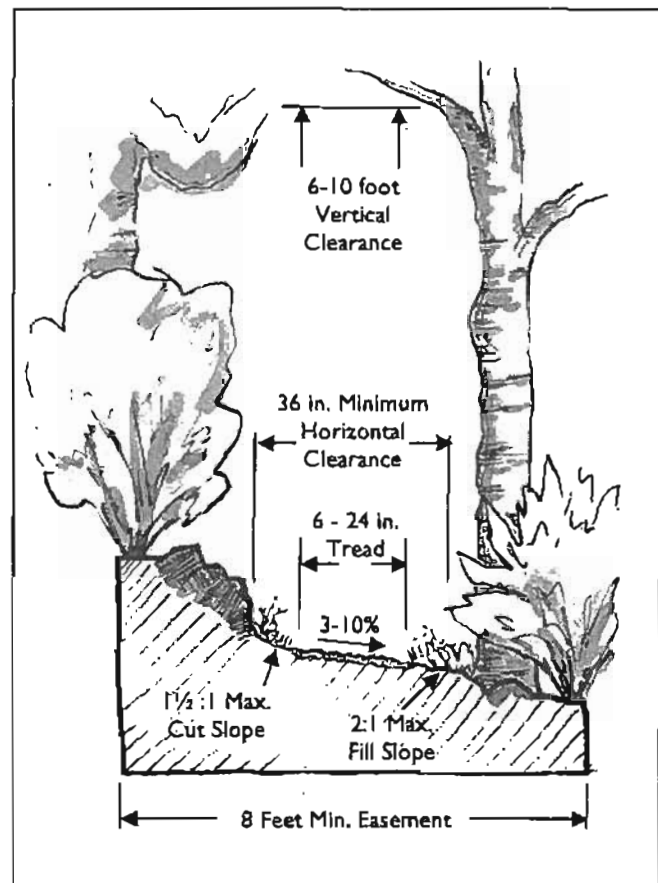

CROSS SECTION - LEVEL I BACKCOUNTRY

City of Homer

Non-Motorized Trail Planning & Design Criteria Summary

Level 2 - Recreation Corridor

NOTE: This is a summary. Refer to Article 5.13 Non-Motorized Trails and Public Access Easements for full description of criteria.

PLANNING CRITERIA

Locations

- Groomed X-country ski trail corridors, or light use trails in public parks and recreation areas.
- Within utility easements, where the corridor has historic use as a recreational route and there are no existing or anticipated use conflicts or concerns with utilities or adjacent land use.
- Light use trail connections between residential areas and recreation destinations, where topography allows for gentle grades with little or no cut / fill.
- Wetland Routes - unimproved ski or snowshoe routes across wetlands, for winter use only.

Use Primarily a recreation route for light to heavy volumes of traffic, depending on the use. Heavy use for winter only. May be designed for one-way or two-way bicycle trails, classic and/or skate skiing, hiking and snow-shoeing, or equestrian use.



Level 2 Trail Description

A basically unimproved, informal, wide, flat or gently sloping natural surfaced trail corridor cleared and/or mowed for single or multi-use recreation in rural or semi-rural areas or within public parks or recreation areas.

Easement Width 20 feet minimum. Wider, as needed, for safe turns, intersections, or where use requires a wider clear zone.

Trail Maintenance Mowing optional. Cut vegetation within clearance zones, and provide repairs or upgrades to trail surface, water crossings, signage and other amenities or structures, as needed, and as funding allows. Winter grooming optional. Seasonal installation of trail signs or markings on winter use trails, as needed.

Topography Generally located in flat to gently sloping areas. Must be able meet design criteria for the intended use with minimal disruption to natural terrain. Side slope: Max. approx. 20% (~2.5 feet difference) across a 12 foot wide easement, 10% is recommended for bicycle routes.

Alignment

- The route may align with an existing utility easement corridor, if topography meets Level 2 running grade and cross-slope criteria. Occasional areas of moderate cut / fill allowed to level cross-slopes or soften grade changes.
- Wide curves. Meander as necessary to construct the trail with minimum disturbance to natural surroundings.
- Never align trail to run directly up or down slope. Provide turns and grade reversals to prevent erosion.
- Connects to similar trails, trail heads or recreation areas.
- Access trail to a Level 1 trailhead.
- Avoid alignments that result in maximum grades within 20 feet of intersections.
- Water Crossings: Minimize or avoid crossing ground seeps, creeks, wetlands, or other water bodies, other than for winter use only routes.

Soils, Water & Hydrology Saturated soils are highly susceptible to erosion. Avoid seeps and other areas with seasonally saturated soils. Minimize the crossing of creeks, rivers and wetlands. These structures are more expensive to construct and maintain. Avoid constructing trails along side slopes of 20% or greater.

City of Homer
Non-Motorized Trail Planning & Design Criteria Summary
Level 2 - Recreation Corridor

NOTE: This is a summary. Refer to Article 5.13 Non-Motorized Trails and Public Access Easements for full description of criteria.

TRAIL DESIGN CRITERIA

Trail Width & Shoulders 6 - 16 foot wide grass corridor for a variety of low volume year-round recreational use. A worn central tread area may occur naturally over time.

- 6 foot wide trail in areas with challenging terrain, more cross-slope, wet soils, or other restrictions.
- 8-12 foot wide corridors are the standard - a mix of hiking, snowshoeing, biking, informal skiing, low volume equestrian.
- 16 foot wide corridor for ski routes that are groomed for both classic and skate ski.

Surface Native earth or ground cover with limited grading, imported material and/or seeding. Porous pavement panels or turf reinforcement materials may be used in wet areas. Generally clear, with protrusions <6 inches. No steps or retaining structures.

Clearance

- Vertical clearance - 12 feet minimum above both trail and shoulders.
- Horizontal clearance - Vegetation clear zone 8-20 feet, depending on use. 2 feet beyond each side of trail.

Grade

- Target grade: <10%. Maximum: 15% for distances up to 50 feet.

Cross Slope of Trail

- Target cross slope - 5% Maximum, where natural cross slope warrants: 10%

Signage & Amenities

- Trail markers as needed to navigate trails year-round.
- Trail information signage posted at each end of the trail: Trail system map (if appropriate), trail name, length, use restrictions or accessibility warnings, and resource protection information.
- Directional signage with trail name and length, at all trail intersections.

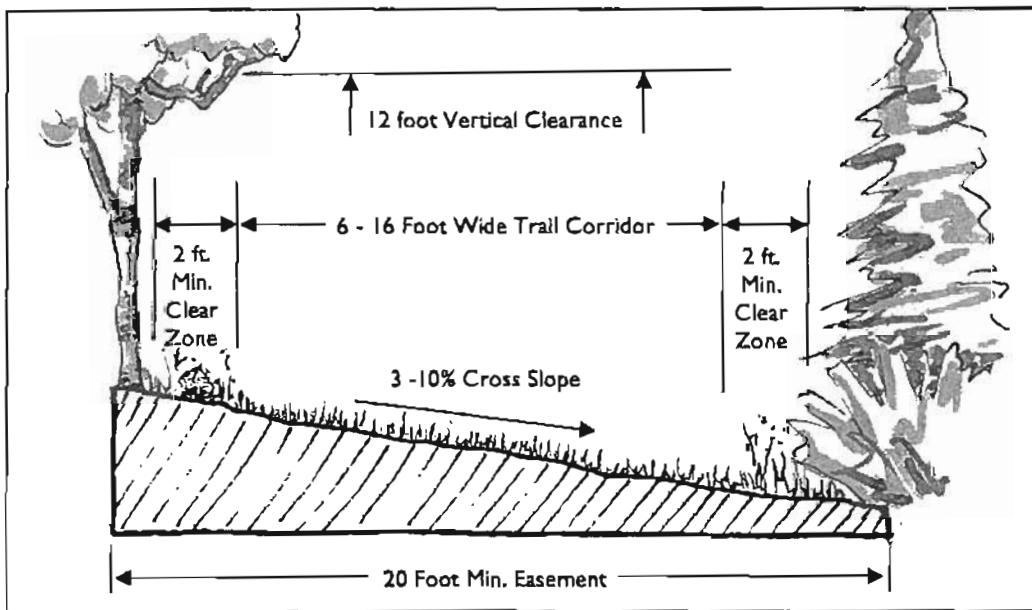

CROSS SECTION - LEVEL 2 RECREATION CORRIDOR

City of Homer
Non-Motorized Trail Planning & Design Criteria Summary
Level 3 Semi-Improved Trail

NOTE: This is a summary. Refer to Article 5.13 Non-Motorized Trails and Public Access Easements for full description of criteria.

PLANNING CRITERIA

Location

- Connections within and between residential areas where use volumes are not high, or where topography precludes meeting Level 4 Trail criteria.
- Light use, or specialized use trails within public parks and recreation areas.
- Rural trails with light to moderate traffic and year-round informal recreational use.

Use Primarily a recreational route for light volumes of traffic. May be designed for one-way or two-way bicycle trails or for equestrian use. Winter use may include snow-shoeing or classical skiing, depending on terrain.

Easement Width 12 feet minimum. Wider easements as needed for curves, side slopes, and maintenance.

Trail Maintenance Yearly maintenance of gravel surface, clearance zones, signage, and amenities. Cut vegetation within clearance zones, and provide repairs or upgrades to trail surface, water crossings, signage and other amenities or structures, as needed, and as funding allows. Winter grooming optional.

Topography Allows for construction to meet design criteria. Existing side slope within easement; Max. approx. 20% (~2.5 feet difference) across 12 foot wide easement.

Alignment Level 3 trails provide casual recreation and transportation routes through semi-rural to rural areas. They connect neighborhoods, parks, or other recreation destinations.

- The route can meander as necessary to construct the trail with minimum disturbance to natural surroundings.
- Route should not run directly up slope, but rather traverse a slope at <math><30^\circ</math> angle to the slope, with occasional grade reversals.
- Trail has public access at all ends, such as other trails of equal or greater Level, a parking lot, street ROW, park, school, etc.
- Connects to Level 5 or Level 4 trails. A Level 1 trail may branch from a Level 3 trail.
- Avoid alignments that require maximum grades within 20 feet of intersections with trails, rights-of-way or parking areas.
- Stairs are only allowed on Level 3 trails when an alternate alignment is not reasonable and when grades would otherwise exceed Level 3 maximums.
- Water Crossings: Minimize or avoid crossing ground seeps, creeks, wetlands, or other water bodies. Align crossings at 90° to water flow, choose narrow crossings, avoid crossing river bends or near naturally eroding banks.

Soils, Water & Hydrology Saturated soils are highly susceptible to erosion. Avoid seeps and other areas with saturated soils. Minimize the crossing of creeks, rivers and wetlands, which is more expensive to build and more difficult to maintain. Avoid constructing trails along side slopes of 20% or greater.

Level 3 Trail Description

An informal trail through semi-urban to rural areas, used for access between neighborhoods and destinations, or for recreation. Accessibility may be limited.



City of Homer
Non-Motorized Trail Planning & Design Criteria Summary
Level 3 Semi-Improved Trail

NOTE: This is a summary. Refer to Article 5.13 Non-Motorized Trails and Public Access Easements for full description of criteria.

TRAIL DESIGN CRITERIA

Trail Width & Shoulders 3 - 5 foot wide Improved trail.

- 3 - 4 foot wide trail - for routes with lower volumes of traffic, and one-way or no bicycle use.
- 5 foot wide trail - for routes with moderate to high pedestrian volumes and/or two-way bicycle or equestrian uses.
- Trails should widen in areas of switchbacks, turns, steep side slopes, and as needed near structures or amenities.

Surface 4 inches NFS gravel over geotextile fabric, which may be placed over native vegetation. Alternate surfacing: porous pavement panels filled with native or imported material. Medium duty boardwalk or bridges where needed. Generally clear, with protrusions <4 inches and steps to 10 inches.

Clearance

- Vertical clearance - 8 feet minimum. Optimum 12 feet for winter and equestrian users.
- Horizontal clearance - 12 in. beyond trail edge. 24 in. from signs, trees or structures.

Grade

- Target grade < 8%, with grade reversals as needed to control erosion.
- 15% maximum for up to 50 feet.

Cross Slope of Trail

- Target cross slope - 3%, flowing to downside of tread, or to uphill side, if a drainage ditch is provided.
- Maximum - 10%

Signage

- Trail markers (as needed) to navigate winter use trails.
- Trail information signage posted at each end of the trail: Trail system map (if appropriate), trail name, length, use restrictions or accessibility warnings, and resource protection information.
- Directional signage with trail name and length, at all trail intersections.

Amenities

- Few amenities, as approved by City of Homer, such as bear proof trash receptacles, trail heads, benches for rest or viewing, interpretive signs, such as at interesting historic or natural features.

Structures

- Medium duty structures, as needed.
- Elevated plank crossing of wetlands, creeks.
- Few railings or boardwalks.
- Log, timber or rock retaining structures for cut / fill edges, as needed.

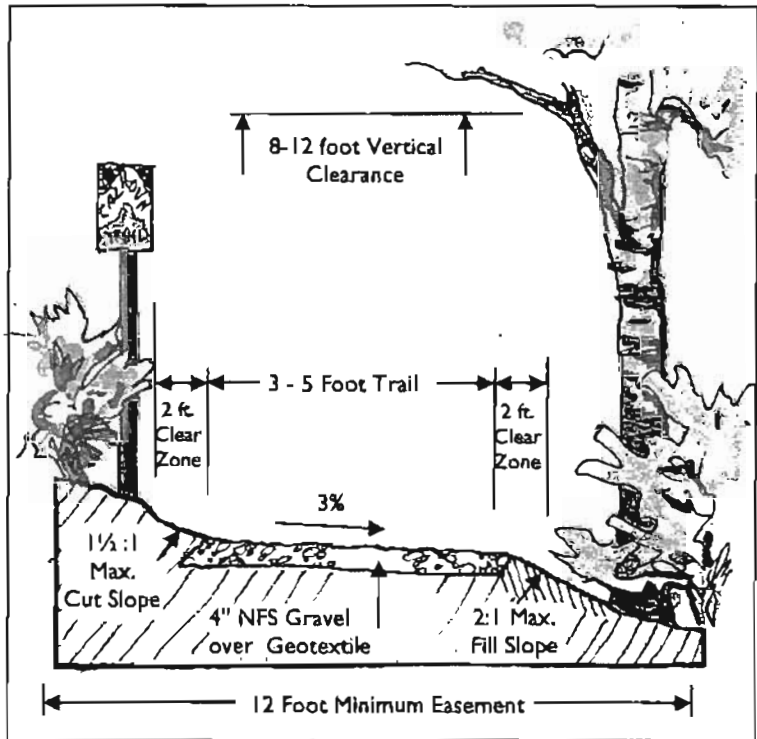

CROSS SECTION - LEVEL 3 SEMI-IMPROVED TRAIL

City of Homer
Non-Motorized Trail Planning & Design Criteria Summary
Level 4 - Fully Improved Trail

NOTE: This is a summary. Refer to Article 5.13 Non-Motorized Trails and Public Access Easements for full description of criteria.

PLANNING CRITERIA

Location

- For transportation and recreation routes through core civic or commercial areas and residential neighborhoods with moderate use levels.
- Where recreational use volumes are high and full accessibility is not critical.
- Moderate pedestrian activity, especially where accessibility is not critical.
- Where a Level 5 trail width is needed to accommodate volumes and user groups, but costs or topography preclude construction of a fully accessible route.

Use Two-way transportation routes with light to moderate volumes of primarily pedestrian & bicycle traffic. They may be designed for use by skiers and equestrians, where appropriate.

Easement Width 15 feet minimum.

Trail Maintenance Maintenance of clearance zones, trail surface, water crossings, signage and other amenities or structures, as needed, and as funding allows. Regular maintenance of approved trash receptacles. Winter maintenance, as use volumes dictate, and funding allows.

Topography Allows for construction with maximum running grades <8%, Existing side slope within easement: Max. approx. 12% (~2 feet difference) across width of easement, unless using retaining structures.

Alignment Level 4 trails provide comfortable, moderately accessible transportation and recreation routes with the following criteria:

- The route provides a fairly direct connection between major destinations, with spurs and exits where possible.
- Trail has public access at all ends.
- Avoid using stairs, where possible.
- Connects to Level 5 or Level 4 trails. Lower level trails may branch from a Level 4.
- Avoid alignments that require maximum grades within 20 feet of intersections with trails, rights-of-way or parking areas.
- **Water Crossings:** Minimize or avoid crossing ground seeps, creeks, wetlands, or other water bodies. Align necessary crossings at 90° to water flow, choose narrow crossings, avoid eroding banks.

Soils, Water & Hydrology Saturated soils are highly susceptible to erosion. Avoid seeps and other areas with saturated soils. Minimize the crossing of creeks, rivers and wetlands, which is more expensive to build and more difficult to maintain. Avoid constructing trails along side slopes of 20% or greater.

Level 4 Trail Description

A wide multi-use trail with a firm surface meeting ADA accessibility standards for recreation trails. A transportation and recreational route through the developed areas of Homer and within residential neighborhoods.



City of Homer
Non-Motorized Trail Planning & Design Criteria Summary
Level 4 - Fully Improved Trail

NOTE: This is a summary. Refer to Article 5.13 Non-Motorized Trails and Public Access Easements for full description of criteria.

DESIGN CRITERIA

Trail Width & Shoulders 5 - 8 foot wide paved or gravel trail.

- 5 - 6 foot wide trail - for routes with lower volumes of traffic, and fewer recreational users.
- 7 - 8 foot wide trail - for routes with bicycles and/or moderate to high user volumes.
- PAVED TRAILS - where a Level 5 trail is recommended, but topography or other physical conditions prevent construction to Level 5 standards, a paved Level 4 trail is acceptable. Any Level 4 trail can be paved. Provide a minimum 12 in. gravel shoulders on all paved trails.

Surface Firm and stable. Smooth, few or no obstacles. Protrusions <3 in. Steps to 8 in. Remove surface vegetation and organic soils. For gravel trails: 2 in. leveling course over 8 in. NFS gravel over geotextile. For paved trails: 2 in. AC pavement over 2 in. leveling course over 24 in. NFS gravel over geotextile. Alternate surfacing: PPP filled with native or imported material.

Clearance

- Vertical clearance - 9 feet above trail and shoulders, 12 feet for equestrian use.
- Horizontal clearance - Minimum 12 in. beyond trail edge. 24 in. from signs and trees.

Grade & Accessibility

- Accessible trails: Target grade ≤ 5%, 8.33% for up to 200 feet, 10% for up to 30 feet, 12.5% for up to 10 feet. No more than 30% of trail length shall exceed 8.33%.
- Maximum: 10% for up to 50 feet.
- Stairs used where absolutely necessary and pedestrians are the primary user group.

Cross Slope of Trail

- Gravel trails - 3%
- Paved trails - 2%
- Shoulders - 10% Max.

Signage

- Trail information signage posted at ends and intersections, as necessary, such as a trail system map, trail name, use restrictions, accessibility warnings, and resource protection information.
- Directional signs for nearby destinations, traffic control and warnings for intersections or other trail conditions.
- Directional signage with trail name and length, at all trail intersections.

Amenities

- Amenities common. Lighting, bear proof trash & recycling receptacles, maps, benches for rests or viewing, and interpretive signs, as approved.

Structures

- Heavy duty structures, as needed: bridges, boardwalks, retaining structures, railings.

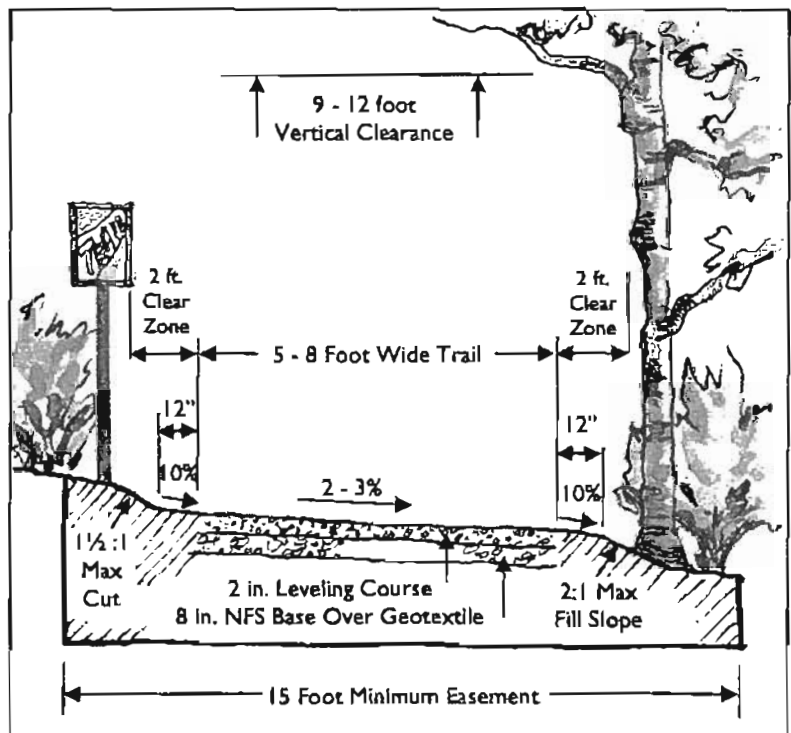

CROSS SECTION - LEVEL 4 FULLY IMPROVED TRAIL

City of Homer

Non-Motorized Trail Planning & Design Criteria Summary

Level 5 - High Use Trail

NOTE: This is a summary. Refer to Article 5.13 Non-Motorized Trails and Public Access Easements for full description of criteria.

EASEMENT PLANNING CRITERIA

Locations

- Where required or recommended in Codes or Plans adopted by the City of Homer.
- Long, regional commuter routes.
- On-site pedestrian routes, as required by ADAGG, and any accessible connections between these and nearby pedestrian routes, such as sidewalks.
- Connections between Level 5 Trails and nearby streets, trails, public areas, or other destinations.
- Where high volumes and/or varied types of users are known or anticipated to use the existing route.

Use Accommodates two-way traffic of pedestrians, cyclists, in-line skaters, wheelchair users, and others. May be year-round for pedestrians, bicyclists, and wheelchairs.

Easement Width 20 feet wide minimum. Additional width may be needed to accommodate bridges, cut / fill needs, curves, trail amenities, or maintenance.

Trail Maintenance Maintain clearance zones, trail surface, water crossings, signage and other amenities or structures, as needed, and as funding allows. Regular maintenance of approved trash receptacles. Full winter maintenance as use dictates and funding allows.

Topography Must allow for an accessible trail without excessive cut / fill requirements; Structural slope management techniques, such as retaining walls, are encouraged as needed to meet design criteria with minimal impact to surrounding areas.

Alignment The primary objective is to provide accessible pedestrian transportation routes or high use recreation routes. Alignment should be based on the following criteria:

- Efficient and direct routes between origins and destinations;
- Avoid creating tunnels or blind corridors with restricted visibility;
- Avoid trail alignments that direct views into private residences;
- Align trail, where possible, to provide views of natural features and destinations;
- Water Crossings: Minimize or avoid crossing ground seeps, creeks, wetlands, or other water bodies. Align necessary crossings at 90° to water flow, choose narrow crossings, avoid eroding banks.

Soils, Water & Hydrology Saturated soils are highly susceptible to erosion. Avoid seeps and other areas with saturated soils. Minimize the crossing of creeks, rivers and wetlands, which is more expensive to build and more difficult to maintain. Avoid constructing trails along side slopes of 20% or greater.

Level 5 Trail Description

A wide, accessible paved trail that accommodates a wide variety of non-motorized users.



These multi-use trails provide access between public spaces, sidewalks, civic & cultural buildings and other major destinations within the core civic and commercial areas of Homer. Winter maintenance can allow for convenient year round use of these transportation and recreation routes.

City of Homer

Non-Motorized Trail Planning & Design Criteria Summary

Level 5 - High Use Trail

NOTE: This is a summary. Refer to Article 5.13 Non-Motorized Trails and Public Access Easements for full description of criteria.

TRAIL DESIGN CRITERIA

Trail Width & Shoulders. 8- 12 foot wide paved trail with 2 foot wide gravel shoulders.

- 8 foot Trail - for routes with lower volumes of traffic, few recreational users, or space limitations.
- 10 foot wide trail sections are the standard.
- 12 foot wide trails are recommended where traffic volumes are high, bicycles and in-line skates are common, near intersections with other trails or streets, as the trail approaches a bridge, where grades exceed 5% and handrails are provided, or near points of interest along the trail.
- **ALTERNATE TRAIL DESIGN** - Where trail is highly recreational, with bicycles, equestrians, joggers, an alternative design of 6 foot wide paved trail with 4 foot shoulders on each side or a trail with one 2 foot and one 6 foot wide shoulder is allowable. Or, provide a separated dual trail, one paved, one gravel, with a vegetated median in-between.

Surface. Uniform, firm and stable. Pavement or boardwalk. Smooth, no obstacles. Protrusions <2 inches. Construct using 2 in. AC pavement over 2 in. leveling course over 24 in. NFS gravel over geotextile fabric.

Clearance.

- Vertical clearance - 9 feet above trail and shoulders, 12 feet for equestrian use.
- Horizontal clearance - Minimum 24 inches beyond trail edge. 36 inches for posts and structures.

Grade

- Accessible Trails: Target grade ≤ 5%, 8.33% for up to 200 feet, 10% for up to 30 feet, 12.5% for up to 10 feet. No more than 30% of trail length shall exceed 8.33%.

Cross Slope of Trail

- Target cross slope - 2% Shoulders - 10% Max.
- Maximum, where needed for driveway crossings or other intersections - 3%

Signage

- Trail information signage posted at ends and intersections, as necessary: Trail system map (if appropriate), trail name, use restrictions or accessibility warnings, and resource protection information.
- Directional signs for nearby destinations, traffic control and warnings for intersections or other trail conditions.
- Directional signage with trail name and length, at all trail intersections.

Amenities

- Amenities common. Lighting, bear proof trash & recycling receptacles, maps, benches for rests or viewing, and interpretive signs, such as at historic or natural features.

Structures

- Heavy duty structures, as needed: bridges, boardwalks, retaining structures, railings.

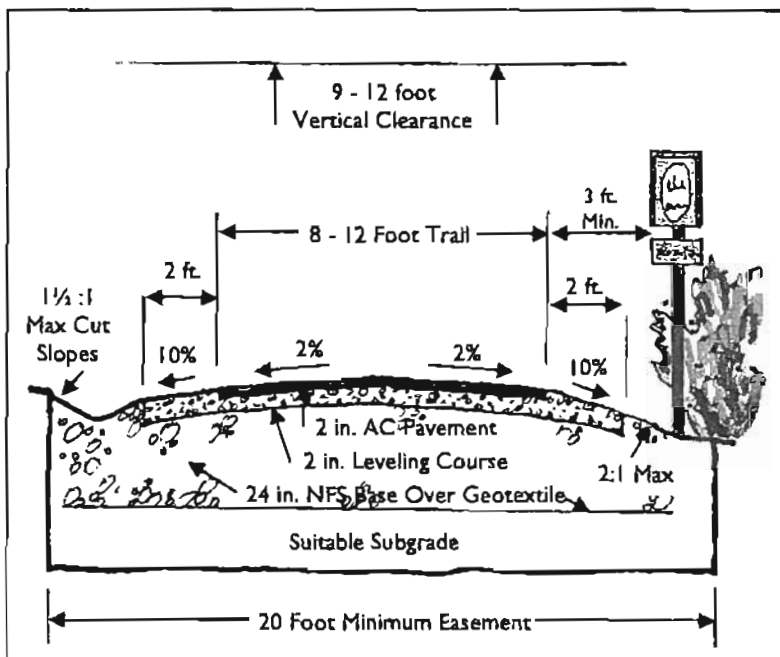

CROSS SECTION - LEVEL 5 HIGH USE TRAIL

D. TRAIL DESIGN CRITERIA

I. GENERAL

The City of Homer's goals include having non-motorized trails that provide for a range of accessibility and experiences, through varying terrain and neighborhoods for a range of users. Such a system of trails will provide year round transportation and recreation routes throughout the City of Homer.

Accessible trails are expected within the central development area of Homer, connecting pedestrians to schools, parks, the hospital, the library, residential neighborhoods, businesses, and other public facilities.

a. Objectives

This section provides design criteria for trail alignment, width, grade, cross-slope, clearance, materials, steps, railings, signage, boardwalks, ramps, switchbacks, water crossings, structures, bridges, and specialized uses. It is for use by project engineers when designing a trail and by City of Homer staff when reviewing applications for subdivisions, easement dedications, or trail construction.

The objective is to provide design criteria for most typical trail situations; however, the design criteria in this article does not dismiss the responsibility of the trail engineer or designer from appropriately addressing all site conditions and applying design solutions that are safe, structurally sound, attractive, and functional. Refer to the list of resources in section A.3.a. of this article when more specific design research is necessary for unique circumstances or issues.

2. TRAIL ALIGNMENT

Trail alignment refers to the horizontal and vertical curvatures of the trail, and is responsible for ensuring the safety and comfort of trail users. Many factors are involved in determining a safe and effective alignment for a specific trail, including user volumes and types, and the condition, width and grade of the trail. For example, a wide, paved trail with an 8% grade will produce faster speeds and require broader curves and longer sight stopping distances.

a. Design Speed

Design all trails based on the preferred speed of the fastest users, which are typically bicyclists and cross-country skiers. According to AASHTO's Guide for the Development of Bicycle Facilities, 1999, a paved shared use trail (Level 4 or 5) should be designed for a minimum speed of 20 mph, which is the appropriate maximum speed for a bicyclist on a paved trail. The design speed should increase to 30 mph if the grade exceeds 4 percent or where strong winds are prevalent.

On unpaved trails, such as Levels 1, 2, 3 or 4, a design speed of 15 mph is adequate. For ski trails with 0-4 percent grade, use a design speed of 15 mph, for grades 4-10 percent, 20 mph, and for grades over 10 percent, 25 mph. Where ski racing events are expected, higher design speed may be necessary.

D. TRAIL DESIGN CRITERIA

b. Horizontal Alignment

Horizontal alignment addresses the curvature of a trail corridor, and must be calculated to accommodate the user group with the greatest needs in order to provide a safe and comfortable trail facility. AASHTO recommends using the bicycle to calculate horizontal alignment on multi-use trails that are used by bicycles. The bicycle has a tendency to lean into a curve as needed to round a corner while traveling at top speed, but without a high rate of superelevation, the lean may result in the pedals striking the trail surface. Increasing the superelevation beyond 3%, however, does not comply with ADA requirements for pedestrian facilities. Therefore, multi-use trails need to accommodate a wider curve radius in order to accommodate both the speed of cyclists and the comfort of all pedestrians.

For Level 2, 3, 4 & 5 trails, use the formulas on this page to calculate curvature requirements, based on bicycle speed.

Table D-1

Desirable Minimum Radii for Paved Multi-Use Trails Based on 15° Lean Angle (AASHTO, 1999)	
Design Speed (V)	Minimum Radius (R)
mph	Feet (ft)
12	36
20	100
25	156
30	225

Use the following simple equation to determine the minimum radius of curvature for any given lean angle:

$$R = \frac{0.067 V^2}{\tan \Theta}$$

R = Minimum radius of curvature (m) or (ft)
 V = Design Speed (km/h) or (mph)
 Θ = Lean angle from vertical (degrees)

Table D-2

Desirable Minimum Radii for Paved Multi-Use Trails Based on 2% Superelevation Rates and 20° Lean Angle (AASHTO, 1999)		
Design Speed (V)	Friction Factor (f) (paved surface)	Minimum Radius (R)
mph		ft
12	0.31	30
20	0.28	90
25	0.25	155
30	0.21	260

For gravel trails and situations where the lean angle approaches 20°, the following formula can be used:

$$R = \frac{V^2}{15(e/100 + f)}$$

Where:
 R = Minimum radius of curvature (ft)
 V = Design Speed (mph)
 e = Rate of bikeway superelevation (%)
 f = Coefficient of friction

D. TRAIL DESIGN CRITERIA

c. Stopping Sight Distance

Trail users need adequate time to see and react to unexpected obstacles or situations along a trail. Appropriate stopping site distances help to prevent accidents and provide a safe and comfortable environment for trail users. Proper design is based on the trail's design speed and is accomplished by the vertical and horizontal curvature and clearing limits of the trail corridor. The following summarizes AASHTO recommendations for providing effective Stopping Sight Distances. Consult AASHTO for more detailed information, diagrams and tabulated charts.

Stopping distance is a function of the trail user's perception and reaction time, the initial speed they're traveling, the coefficient of friction between the trail user and the trail (tires, wheels, skis), and the stopping ability of the user (brakes, etc.). Since many users tend to 'hug' the middle of the trail, lateral clearance on horizontal curves should be calculated based on the sum of the stopping sight distances for trail users traveling in opposite directions. If this is not feasible, place warning signs (in accordance with MUTCD), widen the trail through curves, and/or install centerlines.

For Minimum Stopping Site Distance vs. Grades for Various Design Speeds:

$$S = \frac{V^2}{30(f \pm G)} + 3.67V$$

For Minimum Length of Crest Vertical Curve (L) Based on Stopping Sight Distance:

$$\text{When } S > L \quad L = 2S - 900 / A$$

$$\text{When } S < L \quad L = AS^2 / 900$$

Height of cyclist's eye = 4.5 feet Height of object = 0 feet
Minimum Length of Vertical Curve = 3 ft.

For Minimum Lateral Clearance on Horizontal Curves:

$$M = R [1 - \cos (28.65S / R)]$$

$$S = R / 28.65 [\cos^{-1} (R-M / R)]$$

A = Algebraic grade difference (%)

S = Stopping sight distance (ft)

V = Velocity (mph)

f = Coefficient of friction (use 0.25)

G = Grade rise/run (ft/ft)

L = Minimum length of vertical curve (ft)

R = Radius of centerline of lane (ft)

M = Distance from centerline of lane to obstruction (ft)

SOURCE: AASHTO, Guide for the Development of Bicycle Facilities, 1999

D. TRAIL DESIGN CRITERIA

d. Intersections

Safety on a trail becomes most critical at intersections, especially those between a trail and a roadway. Placement and treatment of trail intersections can make all the difference when it comes to the safety and function of a trail system. Consult AASHTO and MUTCD for additional guidance when designing trail intersections. Trail intersections are subject to the following design criteria:

i) Criteria for All Intersections:

- Adequate stopping site distances and warning signs should be provided to ensure users will stop before the intersection;
- Provide clear sight lines to see on-coming traffic from all directions;
- All intersections and approaches should be as close to perpendicular as possible and on relatively flat grades. Exceptions include ski trails, or other recreational trails that utilize triangular intersections;
- Where an unpaved path crosses a paved path or road, a paved apron should be provided for the unpaved trail, extending a minimum 10 feet from the paved path or road (AASHTO 1999);
- Widen the intersection area if high volumes of traffic are present, or if the users tend to bunch up or move slowly, such as children, groups, or the elderly.
- Place warning signs 400 feet in advance of intersections.

ii) Trail with Trail Intersections:

- Stop signs are required on one of the two trails, typically the lower level, lower volume, or lower speed trail. See section 8 of this article for additional safety and signage information;
- All intersections on higher level trails should be signed to alert users as to the type of crossing and the expected type of traffic;
- Assign right of way to each intersection, giving one trail priority and requiring the other to stop or yield. Consider the comfort and convenience of the trail user, any unique behavioral characteristics of the user, and trail conditions (approach grades, curves, visibility issues).

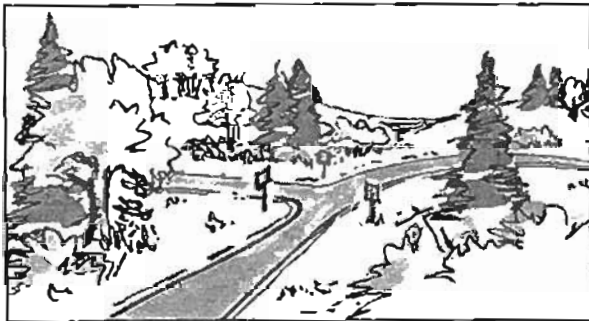

Figure D-1. Visibility and signage at trail intersections.

iii) Trail with Road Intersections:

- If alternate locations for the intersection are available, the most favorable intersection condition should be selected;
- Establish right-of-way and provide traffic control in accordance with MUTCD;
- Sign type, size and location should be in accordance with MUTCD;
- Stop signs should be visible from 200 feet.

D. TRAIL DESIGN CRITERIA

3. GRADE & CROSS SLOPE

This section discusses design criteria for running grade, cross slope, cut / fill, and the use of retaining structures. Grade and cross slope affect the safety, comfort, and sustainability of a trail. Keeping water off a trail is critical to minimizing erosion and reducing puddles and ice build-up on the trail surface.

It is the City of Homer's intent that trails are designed for maximum access with minimum impact. Proposed running grades and accessibility levels are subject to approval by City of Homer Planning or Public Works Departments.

a. Running Grade

Accessibility, topography, soils, construction methods, project budget, and trail use all play a role in determining the appropriate running grade of a trail. In general, grades should be kept to a minimum, especially on long inclines. Comfort and accessibility are a priority on all trails.

i) General Criteria for all Trails.

- Construct all Level 3, 4 & 5 trails to be accessible, unless exemptions apply;
- Apply the "half rule" on all trails, which says that the trail grades should be no more than half the side slope grade;
- Provide grade reversals to manage the flow of water;
- Plan switchbacks to navigate side slopes greater than 15%, to add interest to the trail, and to avoid using maximum grades for long distances. Place switchbacks at relatively flat areas or natural benches. Fewer, longer switchbacks are preferable to frequent, short ones. Switchbacks are not recommended on trails used by bicycles or for skiing.
- Use climbing turns on side slopes <15%.

ii) **Required ADA Accessibility.** Full ADA accessibility (<5% grade) is preferred for higher level trails, but is only required by law on trails that provide primary pedestrian access to facilities that are ADA accessible. For these trails, Table D.3 applies.

iii) **Accessible Trails.** Although not required by law, the Access Board has developed criteria for accessible trails in outdoor developed areas. Level 3, 4 and 5 trails should meet the criteria in Table D.4, unless they meet the exemption criteria.

iv) **Accessible Trail Exemptions.** Portions of trails that meet the following may be exempt from accessibility criteria:

- Compliance would cause substantial harm to cultural, historic, religious, or significant natural features of characteristics.

Table D-3

<p align="center">ADA Pedestrian Accessibility Standards Grades ≤ 5% (1:20) Ramps ≤ 8.33% (1:12) for maximum vertical rise ≤ 30 in. Level landings, 60 x 60 in., are required at each end of a ramp. Hand rails are required for most ramps; Consult ADAAG for more details.</p>

Table D-4

<p align="center">ATBCB Criteria for Accessible Trails 1:20 (5%) any length 1:12 (8.33%) for up to 200 feet 1:10 (10%) for up to 30 feet 1:8 (12.5%) for up to 10 feet No more than 30% of the total trail length shall exceed 1:12</p> <p align="center">Rest Area Criteria Resting areas are required at intervals no greater than the above permitted lengths. 60 inch length, at least as wide as the widest trail segment adjacent to the rest area.</p>

D. TRAIL DESIGN CRITERIA

- Compliance would substantially alter the nature of the setting or the purpose of the facility, or portion of the facility.
- Compliance would require construction methods or materials that are prohibited by Federal, State, or Local Regulations or Statutes.
- Compliance would not be feasible due to terrain or the prevailing construction practices.

v) Running Grade Criteria by Trail Level.

LEVEL 1: Maximum grade is based primarily on the ability of the trail to resist erosion caused by trail use, surface water, or wet soils. Target grade <12%. Maximum 20% for trails where underlying soils are sand, silt, or clay. 20%- 30% for gravel or rock base. For grades over 30%, natural trail base and surface must be composed of angular rock, large rock or solid rock. Provide grade reversals every 20-50 feet. Construct steps to minimize erosion.

LEVEL 2: Target grade: <10%. Maximum: 20% for distances up to 50 feet. Use on-site cut and fill to soften dips or peaks in trail corridor.

LEVEL 3: Target grade: < 8%. Maximum: 15% for up to 50 feet.

LEVEL 4/5: Target grade: \leq 5%. Maximum: 8.33% for up to 200 feet, 10% for up to 30 feet, 12.5% for up to 10 feet. No more than 30% of trail length shall exceed 8.33%.

b. Grade Reversals

A grade reversal is a change in the direction of running grade, from an upslope grade to a down slope grade. They are used on unpaved trails to prevent erosion that is caused by water running *along* the surface of a trail versus *across* the trail. They should be provided every 20-50 feet along the trail corridor.

c. Cross-Slope & Cut / Fill

All trails require enough cross-slope to shed water off the trail surface, but not so much that it impacts the comfort or safety for the trail user. Managing surface water drainage along a trail corridor is critical to maintaining a safe and long lasting trail. Poorly managed drainage can erode soils and destroy vegetation. Keeping water moving across the surface of a trail will prevent ponding, erosion, and icing.

Steep side slopes (> 30%) are a common obstacle to the construction of trails on Homer's hillside terrain, and often trigger the need for extensive cut and fill to "fit" a trail into a hillside. Careful planning can minimize expense and environmental damage.

Figure D-2. An existing fall line trail is re-routed to gradually climb the hill. Grade reversals, or rolling grade dips, are added to create a sustainable trail that sheds water and provides rest areas.

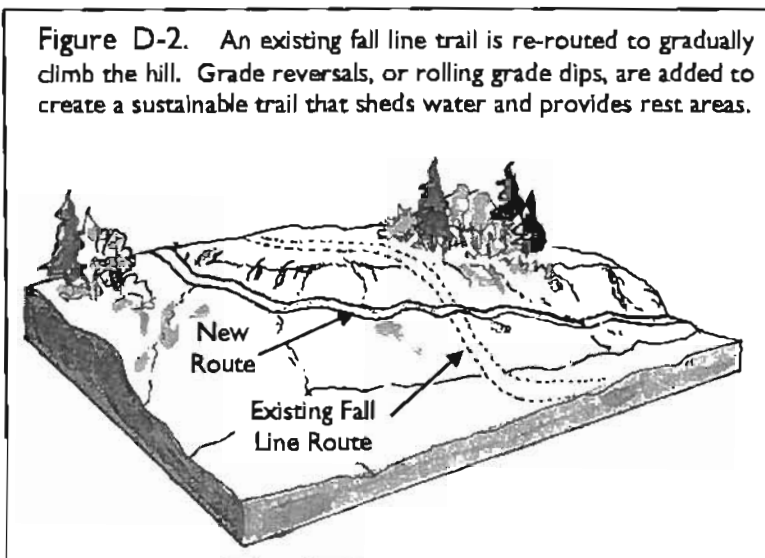

D. TRAIL DESIGN CRITERIA

i) General Cross-Slope and Cut / Fill Criteria:

- All construction-related disturbance, including areas of cut or fill, shall occur within the limits of the easement;
- Limits of cut and fill should be in proportion to the construction level of the trail. For example: low level trails justify very little cut / fill, high level trails may utilize the entire easement for most of the length of the trail;
- Maximum 1½ :1 (75%) cut slopes, maximum 2:1 (50%) fill slopes. Where soils are unstable, sandy, or saturated, 3:1 (33%) max slopes are recommended.
- For trails along side slopes of 30% or greater, construct the trail on the cut bench portion only. Avoid locating the trail on fill portions of the side slope;
- Provide retaining structures, as needed to minimize disturbance and to improve accessibility on Level 3, 4 or 5 trails;
- Construct trails to ensure water flows across or under the trail surface, not along the trail. Where it is necessary to run the water along the trail, it should be contained in a ditch with provisions made to protect against erosion. Ditch length should be minimized by diverting runoff across the trail at the nearest point feasible.
- To accommodate vision-impaired or wheelchair users on Level 4 or 5 trails with an adjacent fill slope, provide a vertical barrier along the cut slope edge of the shoulder, such as vegetation, or a minimum 3 in. curb or barrier.

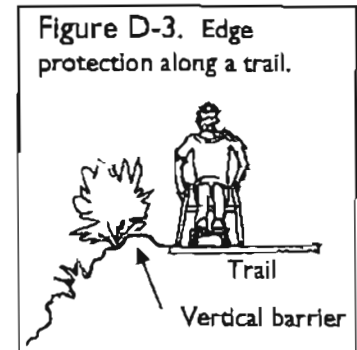

ii) Criteria by Trail Level

LEVEL 1: Target cross slope is 3-10%. Maximum is up to the natural side slope. If the trail is designed for mountain bikes, cross slope maximum is 10%. Very minimal cut and fill. Little or no use of (rustic) retaining methods.

LEVEL 2: Target cross slope: 5%. Maximum: 10%. For ski trails, if bicycles are not allowed, steeper side slopes may be allowed. Minimal cut and fill as necessary to meet criteria and soften dips, ruts, bumps or peaks.

LEVEL 3: Target cross slope is 3%. Maximum is 10%. Cut and fill as needed to meet design criteria. Rock or timber used for most retaining needs.

LEVEL 4: Gravel trails: Target cross slope: 3%, Max.: 4%. Paved trails: target cross slope: 2%, Max.: 3%. Cut and fill may be significant, as needed to meet design criteria. May likely extend to edges of easement for much of the trail length. Imported materials for retaining structures common.

LEVEL 5: Target cross-slope is 2%. Where necessary, such as when crossing driveways, a cross-slope of 3% is allowable. Paved surfaces must be uniform enough to prevent ponding and icing. Shoulders should slope away from the paved sections of the trail with a target slope of 3%, and a maximum of 10%. Cut and fill may extend to the outer edges of the easement. Retaining structures common.

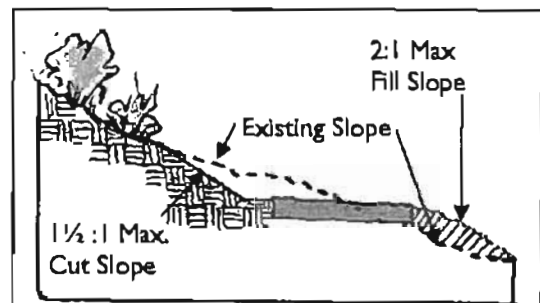

Figure D-4. A Full Bench Trail, placed on cut portion of the slope only, provides a more stable base than a trail placed on fill material.

iii) Re-vegetation. All cut / fill slopes should be vegetated with native species. Attempts should be made to salvage and stockpile existing vegetation for re-use on cut / fill slopes. Avoid reseeding with non-native species.

D. TRAIL DESIGN CRITERIA

4. WIDTHS

The complete trail cross-section is composed of the easement, the trail surface, the shoulders, and the clearance zone. The desired width is primarily related to the volume and mix of users. Secondary considerations include topography, curves, intersections, structures, and amenities.

Table D-5

REQUIRED EASEMENT WIDTHS	
LEVEL 1:	8 Feet
LEVEL 2:	20 Feet
LEVEL 3:	12 Feet
LEVEL 4:	15 Feet
LEVEL 5:	20 Feet

a. Easement Width

The following criteria apply to easement widths:

- A narrower portion of easement may be allowed when available space is limited by existing structures or property boundaries, for a short duration of the trail, and the narrow segment of the trail does not create a safety hazard or an uncomfortable trail segment of trail;
- Vary the easement width as needed to accommodate switchbacks or turns;
- Wider easement sections are allowed where existing side slopes require additional cut and fill, and retaining structures are not feasible, and the widened area is not extensive.

b. Trail Width

The width of the trail surface, or tread, is determined by the volume and type of users, as well as the nature of the terrain and the trail surface. Always provide for the user with the most demanding needs.

LEVEL 1: Trail tread width may range from 6 - 24 inches. Consistent width along the length is preferred, but not required on this level of trail. Natural obstacles and topography may both affect variability of the tread width. Provide 24 in. width when the trail is expected to attract mountain biking, equestrians, snow-shoeing, or skiing.

LEVEL 2: There is typically not a constructed trail tread for recreation corridors. They are a specified width of area that is cleared of woody vegetation and obstacles, mowed (optional), and identified with trail markers for use as a recreation corridor. Minimum width for an un-programmed low use corridor is 6 feet. Groomed ski trail routes require up to a 16 foot wide mowed corridor.

FIGURE D-5 Trail Profile

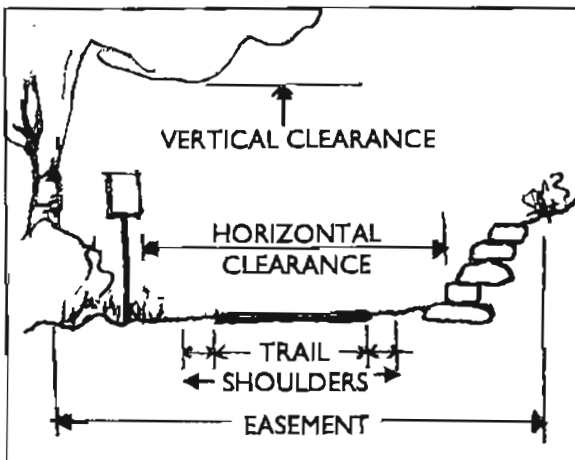

LEVEL 3: Widths may range from 3-5 feet. Safety may be a concern on narrow trails with a mix of pedestrians, bicycles and equestrians, even if the volumes are low. It cannot be expected that bicycles will use these routes as "one-way" trails, or stay off them altogether, so it is imperative that they be designed to mitigate potential hazards. For trails that will expect regular use by bicycles, overall use volumes are moderate, or hills are frequent, the width should be 5 feet. Narrower trails are allowed for lower use trails, but horizontal clearance and sight stopping distance should both be increased, curves widened, and passing areas provided at a minimum of every 1000 feet.

D. TRAIL DESIGN CRITERIA

LEVEL 4: Widths can range from 5 feet to 8 feet wide. Increase widths for trails with higher volumes of traffic, or a wide mix of uses, such as equestrians, joggers, bikes, children, etc. Additional width should be provided as needed for a curve, rest areas or amenities, a passing zone, a transition to a bridge, or at intersections.

LEVEL 5: Widths can range from 8 - 12 feet wide. AASHTO recommends a minimum width of 10 feet for two-directional paved multi-use trail. Where lower volumes of traffic are expected, grades are relatively flat, and views are open, the narrower width is allowable. Wider trails are recommended for areas of high use, with frequent amenities, interruptions or intersections, busy areas with mixed land use, or frequent use by all types of users, including equestrians.

ALTERNATE. Joggers and equestrians prefer gravel surfaces. An alternative trail section may be appropriate where a wide mix of users frequent the trail. Options include an 8 foot wide paved trail with 4 foot shoulders on each side, or with one 6 ft. and one 2 ft. shoulder. A dual trail solution is another alternative for accommodating equestrians more comfortably along side a busy paved trail.

FIGURE D-6 Alternate Trail Profile.

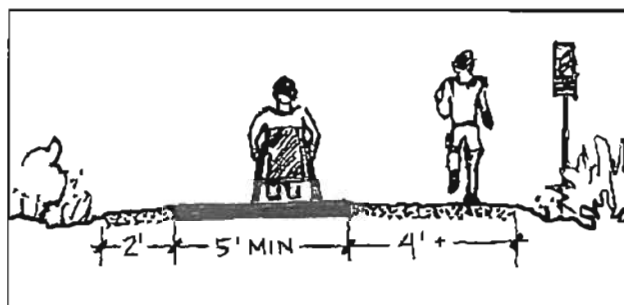

c. Shoulders

Shoulders along side a paved trail offer a transition zone along side the trail, as well as stability for the paved surface. Shoulders are typically needed along all trails, where they abut cut/fill slopes, bridges or other structures, for comfort and safety.

LEVEL 1: Typically none. On bridges, provide minimum 6 in. on each side.

LEVEL 2: Typically none. If a bridge or boardwalk is needed, an additional 2 feet of clearance on each side is recommended.

LEVEL 3: Provide 2 foot wide shoulders for crossing bridges or boardwalks, with or without railings. Provide a 12 in. shoulder between trail edge and cut / fill areas.

LEVEL 4: Provide a 2 foot wide buffer on each side on bridges or boardwalks, with or without railings. Provide 12 in. shoulders between trail edge and cut / fill areas. 2 ft. gravel shoulders required on paved trails.

LEVEL 5: Minimum 2 foot wide gravel shoulders required on all trails.

d. Passing Space

Where Level 3 trails are less than 5 feet wide, 60 x 60 in. passing spaces are required at least every 1000 feet. These areas are to be constructed adjacent to the trail, using the same construction method as the adjacent trail.

D. TRAIL DESIGN CRITERIA

e. Horizontal and Vertical Clearance

One of the most critical factors in developing safe and comfortable trail facilities is the provision of adequate clearance from obstacles that may be found along a trail. Sufficient clearances are needed for visibility and sight distance, trail maintenance, user comfort, passing room, snow storage, crowding, and emergency situations.

Much variability is found in trail clearances, and is based upon the trail design and setting, the various user groups, and the overall volume of users. Adjust clearance as needed for special user groups and maintenance vehicles.

Horizontal clearance refers to the width of clear space from the surface and sides of a trail corridor that is free of obstructions such as rocks, shrubs, amenities, sign posts, trees, railings.

Vertical criteria refers to the height of the clear zone. Trail users are higher when on bicycles, horses or skates, and snow conditions often raise the trail few feet, or more. Highly developed trail settings require a higher vertical clearance, due to our natural shy distance in these environments, compared to our tolerance for tree branches near our heads in wilderness settings.

- LEVEL 1: Horizontal: Maintain 36 inch wide clear zone.
Vertical: 6 ft. Hiking, 8 ft. bicycle & equestrian, 10 ft. snowshoe.
- LEVEL 2: Horizontal: 2 feet additional clearance beyond the edge of the designated trail corridor, or more as needed for ski run-out.
Vertical: 12 feet
- LEVEL 3: Horizontal: 2 feet beyond outer edge of trail to any trees, posts, railings, or signs. 12 in. beyond for other vegetation and cut / fill slopes.
Vertical: 8 ft. for most trails, 12 ft. for equestrian and winter uses.
- LEVEL 4: Horizontal: Minimum 2 feet beyond outer edge of trail to any trees, posts, railings, or signs. 12 in. beyond for other vegetation and cut / fill slopes.
Vertical: 9 ft. for most uses, 12 ft. for equestrians.
- LEVEL 5: Horizontal: Minimum 3 feet beyond trail edge (1 foot beyond shoulder) for any vertical obstructions, such as signs, railings, trees. 2 feet beyond outer edge of trail for vegetation and cut / fill slopes.
Vertical: 9 ft. for most uses, 12 ft. for equestrians.

D. TRAIL DESIGN CRITERIA

5. TRAIL CONSTRUCTION

Trails should be constructed to last a very long time. High quality construction results in a more safe, enjoyable and low maintenance trail. Design higher level trails to withstand snow removal or maintenance vehicles, such as trucks.

a. Trail Base

The base material, or structure, under the trail surface is responsible for the trail's ability to endure loads and repeated freeze-thaw cycles. A soils investigation is required prior to trail design and will have a bearing on the engineering of the trail. More highly constructed or rigid trail surfaces, such as pavement, bridges and boardwalks, require more highly engineered base structure, such as excavating native material and replacing with NFS material, or using piles that are driven to a depth of at least 5 feet. Light use trails require minimal engineering.

b. Trail Surface

Trail surfaces vary with user groups, seasons, volumes and trail locations.

i) **Pavement.** Preferred for high use areas. Paved trails are best for accommodating commuter bicycles, in-line skates, wheelchairs and strollers. Edge reinforcement is recommended where the width of the trail is such that maintenance vehicle tires will likely be at the edge of the pavement.

ii) **Gravel Surfacing.** Suitable for many uses, and is preferred for jogging and equestrian use, but is not as accessible or durable as pavement.

iii) **Natural Surface.** Appropriate for very light summer use, and for winter use. Horses and bicycles can easily damage natural surface trails, especially in wet conditions.

iv) **PPP - Porous Pavement Panels.** Synthetic trail hardening materials are useful in a variety of situations. They are most applicable for wet conditions on Level 1, 2 or 3 trails.

v) **Other surfacing.** Rock, wood, recycled plastic, treated wood, metal.

c. Criteria for Trail Levels

LEVEL 1: Base - Native materials. Surface: native rock, gravel, or earth. For wet crossings use logs, PPP, or other turf reinforcement materials.

LEVEL 2: Base - Native materials. Surface: existing vegetation mat. For wet crossings, use log, metal, synthetic, PPP or other turf reinforcement.

LEVEL 3: Base - Native materials. Surface: 4 in. NFS gravel over geotextile fabric. Wet crossings: wood, metal, synthetic, PPP or other turf reinforcement.

LEVEL 4: Gravel Trails. Base: Remove vegetation and organic soils. 8 in. NFS gravel over geotextile over suitable soil. Surface: 2 in. leveling course.

Paved (or future paved) trails. Base: 24 in. NFS gravel over geotextile. Surface: 2 in. AC pavement over 2 in. leveling course. For wet crossings, wood, metal, synthetic.

D. TRAIL DESIGN CRITERIA

LEVEL 5: Base: Remove vegetation and organic soils. 24 in. NFS gravel over geotextile over suitable soils. Surface: 2 in. AC pavement over 2 in. leveling course. For bridges and wet crossings: wood, synthetic, recycled plastic, treated wood, or metal.

6. STRUCTURES

Where trails cross creeks or traverse areas where existing grades or side slopes are too steep to construct the trail without excessive disruption to adjacent areas, structures may be necessary.

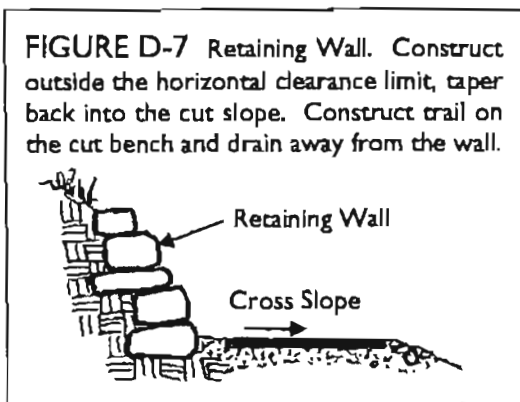

a. Retaining Walls

Construct all retaining walls outside the horizontal clearance limit of the trail. Retaining walls higher than 24 in. on the down slope side of a trail are discouraged. Where necessary, they should include a railing, for safety. Retaining wall materials vary depending on the level of the trail, with rock, concrete block, or timbers used on higher level trails and on-site materials, such as logs or rocks used on lower level trails. Where seeps occur behind retaining walls, provide method to ensure drainage through and under the wall.

b. Steps or Stairs

Steps and stairs are obstacles to many trail users, and are to be avoided, where possible. As needed, construct steps on Level 1 trails using on site materials, such as rocks. Only when all other options, including ramps, have been ruled out, are stairs allowed on Level 3, 4 or 5 trails. When stairs are necessary, consider providing long perron style steps, as strollers and wheelchairs can maneuver them easier.

c. Ramps

Along required ADA accessible pedestrian routes, sections of trail greater than 5% may be considered ramps, and are allowed for limited lengths (see section 3. GRADE & CROSS SLOPE).

d. PPP (Porous Pavement Panels)

These are three dimensional structural grids designed to provide a durable wear surface and load distribution system in wetland and other degradable soils

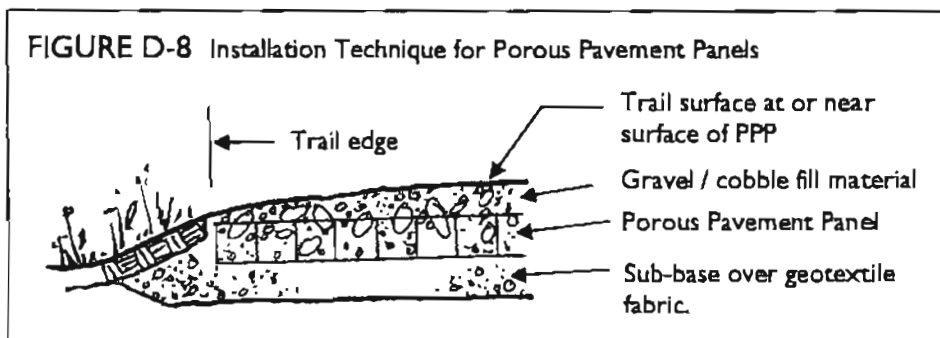

D. TRAIL DESIGN CRITERIA

e. Bridges

Bridges should be designed for pedestrian live loads and for maintenance or emergency vehicles if they may be expected to cross the bridge. Bridge decking should be designed with bicycle safe expansion joints or planks laid perpendicular to the trail direction unless bicycles are not allowed or not expected. Bridge widths should be the same as that of the approach trail plus 2 feet clear area on each side. Bridge decking should be flush with the approaching trail surface.

f. Railings

Railings are provided for safety on elevated trail segments, such as bridges. All railings should be engineered to withstand all loads that may be expected to occur on the bridge. The type of railing that is required is determined by the accessibility level of the trail, and fall into three basic types:

i) **Urban Setting.** Railings in highly pedestrian urban settings must meet International Building Code (IBC) requirements. Railings must be at least 42 inches high with vertical rails to prevent climbing, and be spaced to not allow a 4-inch sphere to pass through. Railings are required on ADA accessible ramps.

ii) **Rural Bridges.** Handrails on bridges or crossings, that are elevated at 30 inches or more, on accessible trails, such as Level 4 & 5 trails, need to meet AASHTO standards for pedestrian highway bridges. These standards require a 6-inch sphere must not pass through the railing in the bottom 27 inches, and an 8-inch sphere must not pass through the area higher than 27 inches. It also requires that the top railing is at least 42 inches for bicycles use, and 54 inches high for equestrian traffic. Rails should also be horizontal to prevent wheels and other objects from catching. All accessible trail bridges that do not have a rail system must have a minimum 3 inch high curb.

iii) **Remote Bridges.** For bridges in remote areas with a drop of 30 in. or more, railing requirements must meet OSHA standards. For typical crossings along Level 1, 2 & 3 trails, handrails are required to be at least 42 inches high for pedestrian traffic and 54 inches high for bicycle and equestrian traffic. They must include an intermediate rail so that vertical distances between rails do not exceed 15 inches between 2x4 wood rails or 19 inches between steel rails.

iv) **Railing Exceptions.** Not all trail bridges require railings. An analysis should be completed to identify and evaluate the bridge's potential users and the hazards of not having a rail system, including situations where a railing is provided on only one side. As a general rule, a remote trail or bridge with a drop of 8 feet or more, should have a pedestrian railing system.



FIGURE D-9 Bridge, railing and typical warning sign on a Level 5 Trail (Urban setting).

FIGURE D-10

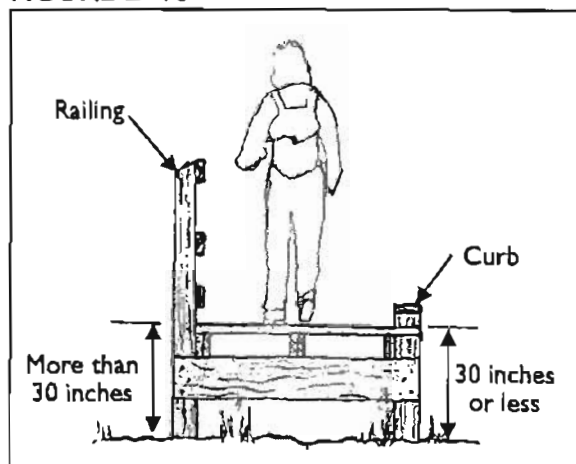

D. TRAIL DESIGN CRITERIA

7. WETLANDS, WATER CROSSINGS & DRAINAGE

a. General Crossing Criteria for all Trails:

- Route the trail to minimize the number and length of crossings;
- Allow for water to pass freely under the trail, with minimal use of piping, culverts, or other constructed passage;
- Best alignment for crossing rivers, streams, and creeks: At a 90° angle on high ground, at a narrow point along the stream and away from curves or eroding soils;
- Best methods for seeps, saturated soils and wetlands: minimize crossing distance, avoid the need for fill, elevate and construct the structure to allow flow of water and growth of plant materials;
- All crossings shall be as wide as the approaching trail, with 1-2 feet additional clearance on each side, depending on the volume and type of users, and the level of the trail.

b. Crossing Techniques

Many techniques are available for use in crossing wet areas along trails. Choose the crossing technique that best suits the users, the volume of use, the trail level, and the specific location. For additional guidelines on wetland crossings, see USDA Forest Service manual titled Wetland Trail Design and Construction, 2007. An investigation of soils and water will help avoid surprises when constructing trails in the hillside terrain. Problematic soil conditions may not be visible until a trail has experienced heavy use.

FIGURE D-10

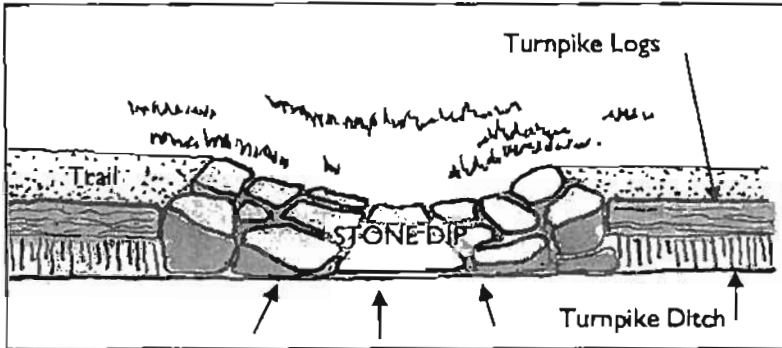

i) **Dips.** Simple and effective ways to drain wet areas. The slope angle and depth vary with soil and water conditions. Stones help reinforce the dip. Geotextile may be installed underneath to prevent fines from washing out.

FIGURE D-11 Underdrain, or French Drain

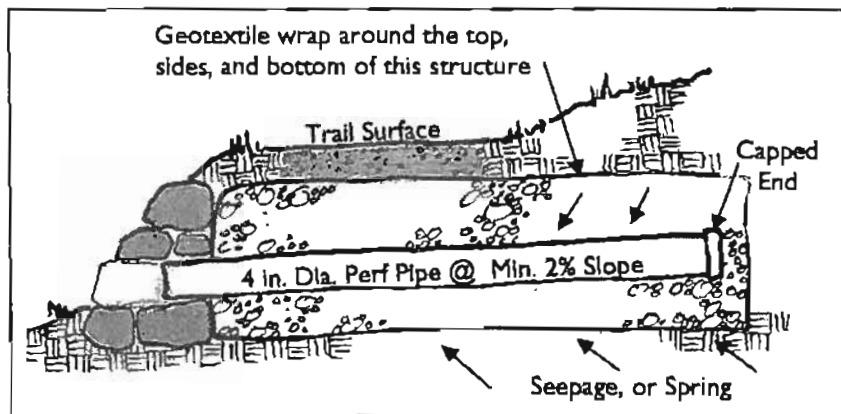

ii) **French Drains or Underdrains.** For crossings over areas of low flow, on low level trails. Trail is constructed over a bed of round rock and perforated pipe, covered with fabric.

SOURCE OF DRAWINGS:
Wetland Trail Design and Construction, USDA Forest Service, 2007.

D. TRAIL DESIGN CRITERIA

iv) **Planks with Piles, Cribbing or Bents.** An elevated trail technique where one or more tread planks are laid parallel to the trail corridor, attached to piles, cribbing, or bents. Choice of support method depends on type of wetland, range of water depth, user volumes, size of trail. Piles are not recommended on low level trails, due to the depth needed to prevent frost heaving.

v) **Puncheons.** A crossing technique for low water areas that utilizes sleepers. Some have linear planks, others also have stringers to support perpendicular decking, which is necessary for bicycle travel.

vi) **Boardwalks.** These are the most substantially constructed form of elevated crossings. They use piles, diagonal bracing, stringers, and planking laid perpendicular to the direction of travel. They often include curbed edges or railings, and can be constructed to suit many user groups, including bicycles and wheelchairs.

vii) **Other Techniques.** Avoid using ditches, culverts or other channelization techniques to divert water, as they may create issues with landslides and super-saturation of soils. Corduroy, turnpikes and causeways are all variations of at-grade wetland crossings, each with their pros and cons. Use of these may be appropriate in some situations, but they are typically not the most environmentally friendly.

c. Materials

Choose materials that are long-lasting and environmentally safe. More investment is expected on higher level trails.

FIGURE D-12 Log Cribbing with Two Sleepers

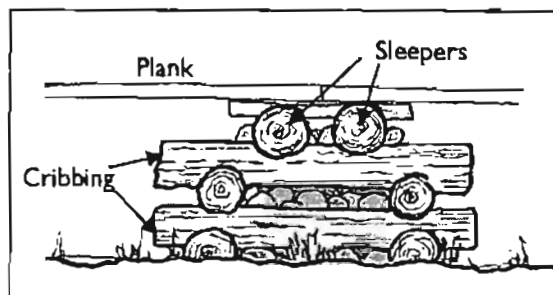

FIGURE D-13 Bog Bridge with Sleepers, or Single Plank Boardwalk

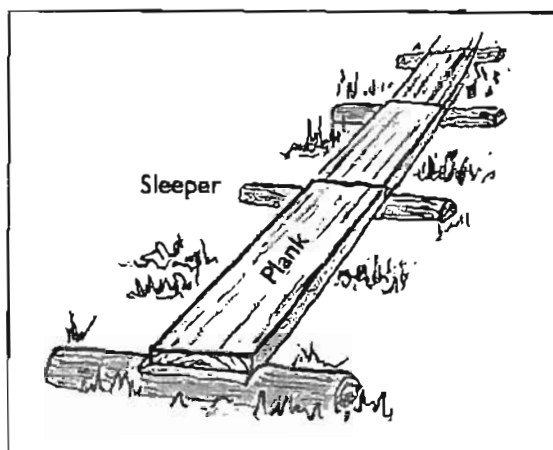

FIGURE D-15 Puncheon

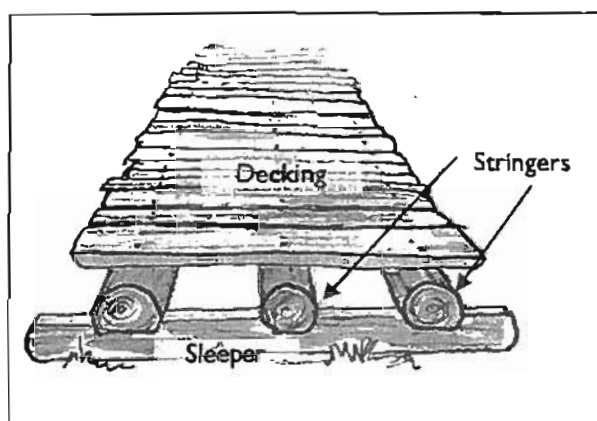
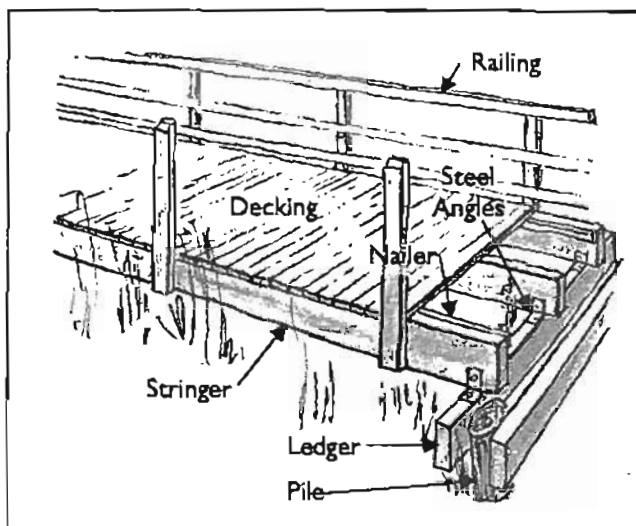

FIGURE D-14 Boardwalk



SOURCE OF DRAWINGS: Wetland Trail Design and Construction, USDA Forest Service, 2007.

D. TRAIL DESIGN CRITERIA

8. TRAFFIC CONTROL, ACCESS & SAFETY

a. Signage & Striping

Signage and marking are essential to ensure the safety, compatibility and enjoyment of multi-use trails. In general, uniform application of traffic control devices, as described in the MUTCD shall be used and will tend to encourage proper behavior. Additional criteria for signage located in D.2.d Intersections.

i) **Trail Identification Signs.** Locate at access points, trailheads, intersections, and at regular intervals along trail corridors. For consistency, use standard tan on brown recreation identification signs. Identification signage may include trail name, allowed and/or restricted uses, trail rules, accessibility level, directional information, and trail length information, as appropriate. Customized trail identification or character signs may be used in addition to standardized brown recreation signs.



FIGURE D-16 Trail signage.

ii) **Traffic Control Signage.** Provide as needed on trails or roadways, in compliance with MUTCD standards, including shapes and colors, where feasible.

iii) **Directional Signs.** are intended to be simple diagrams informing trail users as to trail direction and alignment, and are especially important in busy, high-use locations.

iv) **Regulatory and Warning Signs.** Use for hazards, cautions or for other traffic control information, in accordance with MUTCD. Place no less than 50 feet in advance of the hazard.

v) **Sign Placement.** Signs are intended to be post mounted 4-5 feet above trail grade to bottom of sign (MUTCD). Recommended distance from the edge of the trail or shoulder ranges from 1-7 feet, depending on the type of sign, volumes of users, mix of user groups, trail width, and potential for speed.

vi) **Striping.** Provide centerline striping on paved trails where bicycle traffic is heavy, on curves, and as needed to assist with trail safety. General guidance on marking is provided in the MUTCD.

b. Other Safety Criteria

Provide Detectable Warnings, as required by ADAAG, on the surface of curb ramps, and at other areas where pedestrian ways blend with vehicular ways. Provide detectable edges (no less than 3 in.) along the edge of a trail that abuts a hazard, such as a steep drop, or obstacle.

c. Motorized Vehicle Access and Restriction

Motorized vehicles are prohibited from all trails, except as needed for maintenance or emergencies. In addition to signage, vertical barriers such as bollards, either removable or permanent, posts, vegetation, or boulders may be used to limit vehicular access. Set bollards 48-60 inches apart, and use removable bollards for maintenance access by authorized vehicles.



FIGURE D-17 Boulder used for access restriction.

D. TRAIL DESIGN CRITERIA

d. Trail Heads & Parking

Provide adequate parking, signage and staging areas as needed to accommodate various recreational activities on trails. Amenities such as maps, educational information, trash receptacles, seating, and other trail information are all possible features found at trail heads. Place trail heads and parking areas at the most logical locations along the trail, typically at ends.

9. AMENITIES

Trails are expected to serve many purposes including transportation, recreation, education and social interaction. Amenities, such as benches, trash receptacles, lighting, interpretive panels, and structures are appropriate and necessary for a trail network that meets these objectives. Generally, the higher level trails require more amenities. All amenities should be located outside the trail's clear zone. All amenities provided on accessible trails must also be accessible.

a. Benches

Benches are integral to recreation facilities, and can be used to provide seating for resting, socializing, or viewing. They should be provided at crests of hills, at midpoints of long inclines, in conjunction with other trail amenities, near recreation areas such as playgrounds, and at overlooks or viewpoints along a trail. All benches should meet ATBCB Guidelines for Recreation Facilities.

b. Trash & Recycling Receptacles

Provide bear proof facilities for trash and recycling along higher level trails in locations such as trail heads, rest areas, & interpretive facilities. Locate these facilities for easy maintenance.

c. Lighting

Lighting provides safety and comfort on trails used for transportation, which is primarily Level 4 and Level 5 trails. Where ambient lighting from nearby areas is not adequate to light the trail, additional pedestrian scale lighting may be advisable on these trails, especially at intersections.

d. Information

Trail maps, interpretive information is useful and appropriate in many circumstances along trails, such as to provide information on nearby historic, cultural or natural features. Such amenities enhance the user experience and also protect those community assets. Provide a minimum 4 feet clearance between informational amenities, such as interpretive signs and kiosks, and the edge of the trail.

e. Bicycle Racks

Provide bicycle racks at trail heads, parking areas, and other destinations along the trail corridor. Provide a minimum 4 feet clearance between bicycle racks and the trail.



FIGURE D-18 Trail widens to accommodate interpretive signage.

D. TRAIL DESIGN CRITERIA

10. SPECIAL USES AND CONSIDERATIONS

Where a trail will accommodate a variety of uses, design it for the mode of travel requiring the most demanding design, construction, and maintenance specifications.

a. Winter Only Trails

Level 2 - Recreation Corridors may be located through wetlands, with the intent that these routes are not used during summer months, and that the entire trail segment, or loop, is managed and identified as winter use only. These routes require seasonally installed, removable, vertical identification markers to guide trail groomers and trail users.

b. Ski Trails

Ski trails typically refer to one or two-way groomed x-country tracks and/or skate ski lanes. Minimum widths for classical ski trails is 6 feet. Minimum for a groomed skate track is 12 feet. Grooming for skate skiing with a classical track along side requires 16 feet.

When calculating design speed, turning radii, and sight stopping distance for ski trails, the effects of icy conditions must be considered, as well as any increased speed expected for specific events or races. A skier's speed may be as much as 30 mph at the bottom of a long hill. And, their turning and stopping ability are both impaired. Additional widths and clearances, as well as 'run out' zones are recommended to avoid accidents. On one-way ski trails, doubling travel time is not necessary for calculating sight stopping distance, and hills can be managed for one way travel, providing clearances only where needed for one direction of down-hill travel.

c. Mountain Biking

Assume that mountain bikes will find their way to every type of trail. If designing a trail specifically for mountain biking, refer to design guidelines developed by the IMBA when designing the trail. Always design for pedestrians to share the trail.

d. In-line Skates

For paved multi-use trails that may attract in-line skaters, a minimum 10 foot width is advisable to accommodate a wide mix of users.

e. Beach Access Routes

The U.S. Access Board provides design criteria for beach access in their draft guidelines for Recreational Facilities and Outdoor Developed Areas, 2007.

D. TRAIL DESIGN CRITERIA

f. Equestrian Use

Designing for equestrians involves many special considerations. Horses prefer not to travel on paved surfaces. Horse hooves are very destructive to natural surface trails, especially in wet or soft conditions. Gravel and stone surfaces are the most resilient to horse traffic. Porous pavement panel products can also be very durable and compatible surface hardening materials where equestrians are present.

Compatibility with other user groups can also be an issue. Typically, horses are more comfortable in the presence of pedestrians or motorized vehicles than they are around bicycles. Separation, or at least a wide trail profile, is recommended when both bicycles and equestrians frequent the trail.

Increase horizontal clearance (2-3 feet each side of the trail) for equestrian use. Provide 10-12 feet vertical clearance depending on the character of the trail. Low development setting - 10 foot clearance. Highly developed settings - 12 feet.

For trails that are design for equestrian use, at grade crossings are preferred to bridges, and should be used when practical.

For additional information and design criteria for equestrian facilities, refer to the [Equestrian Design Guidebook for Trails, Trailheads, and Campgrounds](#), produced by the USDA Forest Service, 2007.

FIGURE D-19 Example of a divided trail for equestrian routes where space is available.

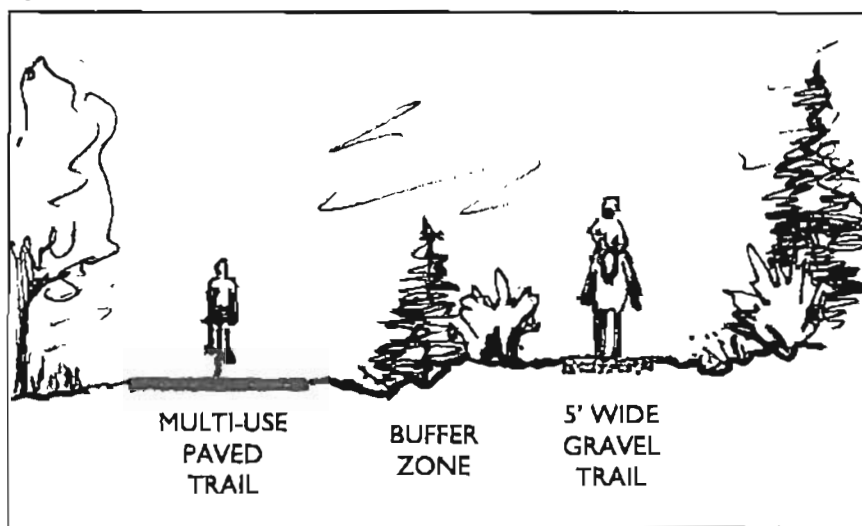

4

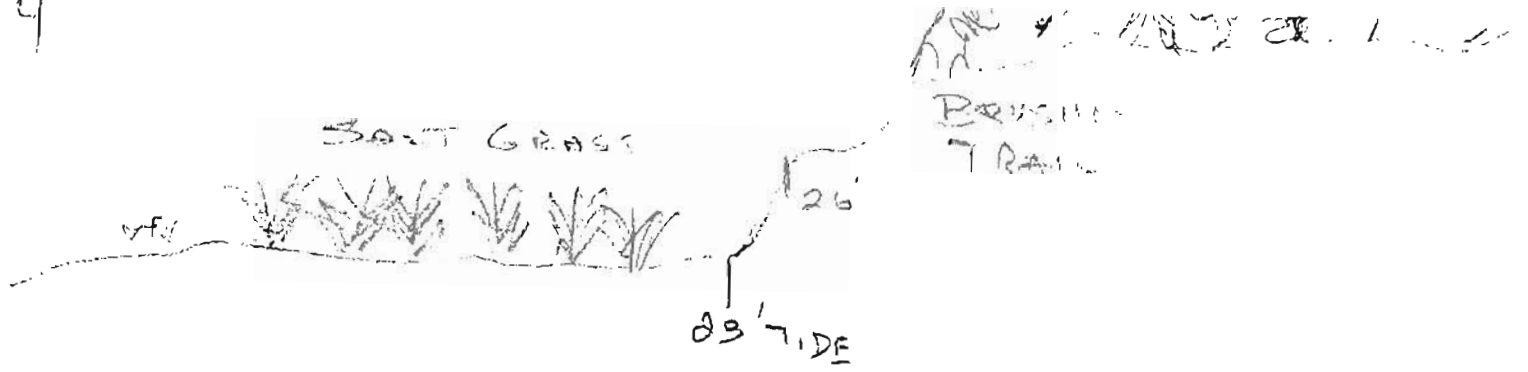

5



6

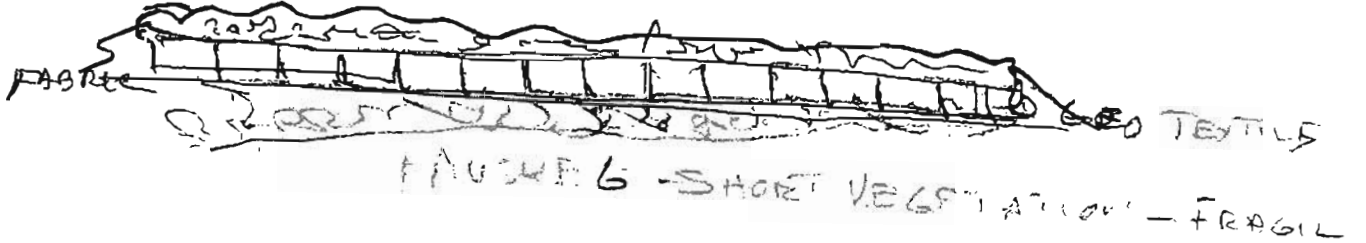



City of Homer Planning & Zoning

491 East Pioneer Avenue
Homer, Alaska 99603-7645

Telephone (907) 235-3106
Fax (907) 235-3118
E-mail Planning@ci.homer.ak.us
Web Site www.ci.homer.ak.us

MEMORANDUM

TO: Mayor Hornaday and Homer City Council
THRU: Rick Abboud, City Planner
FROM: Julie Engebretsen, Planning Technician
DATE: November 2, 2011
SUBJ: Homer Advisory Planning Commission comments on the Kachemak Drive Pathway

At the September 12, Homer City Council meeting, the Council considered Resolution 11-90, brought forward by the Parks and Recreation Advisory Commission. The resolution supported the concept and construction of a pathway or other non-motorized improvement along Kachemak Drive. The Council referred the matter to the Planning Commission.

At the September 21st HAPC meeting, the Commission made and approved the following motions:

- THE ADVISORY PLANNING COMMISSION SUPPORTS THE CONCEPT OF A NON MOTORIZED ACCESS ALONG KACHEMAK DRIVE.
- A LARGE PART OF THIS PROJECT IS A PRIVATE PROPERTY RIGHTS ISSUE THAT SHOULD BE ADDRESSED CAREFULLY FROM THE ONSET. THE UTILITY EASEMENTS ARE PRIVATE PROPERTY.
- THE ADVISORY PLANNING COMMISSION RECOMMENDS THE CITY ADD THE KACHEMAK DRIVE PATH IMPROVEMENTS TO THE STIP NEEDS LIST AS AN AVENUE FOR STATE FUNDING.
- THE COMMISSION APPRECIATES THE EFFORTS OF THE PARKS AND RECREATION ADVISORY COMMISSION AND ENCOURAGES THEM TO CONTINUE WITH THIS GRASS ROOTS EFFORT.

