

CITY OF HOMER

Wayfinding & Streetscape Plan

February 2022 - Technical Review Draft



TABLE OF CONTENTS

DOCUMENT PURPOSE	1
Introduction	2
Purpose And Use Of Document	3
INDEX OF SIGN TYPES	5
Destination - Gateway	6
Directional - Road (ADOT&Pf)	7
Directional - Road (Homer)	8
Information (Homer)	9
Information (Area)	10
Directional - Post	11
Directional - Bollard	12
Destination - Post	13
SIGN DETAIL	15
Destination - Gateway	16
Directional - Road (Homer)	18
Information - Homer & Area	20
Directional - Post	22
Directional - Bollard	24
Destination - Post	26
SPECIFICATIONS & DETAILS	29
Typeface And Colors	30
Sign Graphics	31
Standard Specifications	32
Sign Attachment Detailing	35
Post Cap And Lashing Detailing	39
COST ESTIMATES	41
Cost Estimates	42



DOCUMENT PURPOSE

INTRODUCTION

It is a City of Homer priority to establish a standard wayfinding system and streetscape branding. This Wayfinding and Streetscape Plan sets this standard signage system, providing a strong identity, unified aesthetic, and consistency in wayfinding and the provision of information.

Implementing this signage system unifies people's experience between all roads and streets and helps people identify and locate destinations. The target audiences are both Homer residents (new and long-standing) or visitors. A unified sign design helps users orient themselves and navigate through Homer comfortably.

The signage family is simple, easily recognizable, and legible. Six sign types provide for a variety of situations.

This Wayfinding and Streetscape Plan presents the overall look and feel of the signage family and provides specific information for graphic design, materials, and fabrication. City of Homer staff will determine sign locations on a case-by-case basis, in addition to the informational and graphic content explicit to a particular site.

The City of Homer Wayfinding and Streetscape Plan Package includes the following components:

Index of Sign Types

The Index of Sign Types section provides a quick overview of the sign graphics and content, information on the specific function and proper use for each sign, and their basic components.

Sign Detail

The Sign Detail section provides the standard generic information that is needed for the fabrication of each sign type, and information/guidance on the necessary sign content customization needed for specific locations.

Specifications & Details

The Specifications & Details section provides information required for sign customization, fabrication, and installation.

Cost Estimates

The Cost Estimate section provides expected sign costs at the time of development of this document (December 2021). These costs are expected to change over time.

PURPOSE AND USE OF DOCUMENT

The intent of signage guidelines for the City of Homer's Wayfinding and Streetscape system is to create a cohesive system of presenting information. The goals of such a system are to effectively brand and label major roads, neighborhoods, trails, and facilities; to help people identify and navigate to desired destinations; to provide continuity within and between locations through a common aesthetic; and to streamline the development of new signage and maintenance of existing.

This document serves two purposes: to illustrate the sign types, and to provide the information needed for their fabrication and installation.

The beginning of this document shows the range of sign types and their uses, and provides a hierarchy of applications for guidance in their selection. Key to the proper use of signage is the recognition of how any particular sign fits into an overall hierarchy of information presentation.

Whether an individual sign, or a network of signs, their design and implementation are dependent upon the level of information they are expected to provide. This level of information is dictated through such things as choosing the proper sign, and for how it is used.

This document illustrates the typical information required for each sign, and how this information is typically arranged. Each sign type provides guidance in developing the information needed to develop content for a sign.

Lastly, this document provides the specific information needed to construct each sign type. This includes information for designers or contractors to modify, construct, and install the signs properly.



INDEX OF SIGN TYPES

DESTINATION - GATEWAY

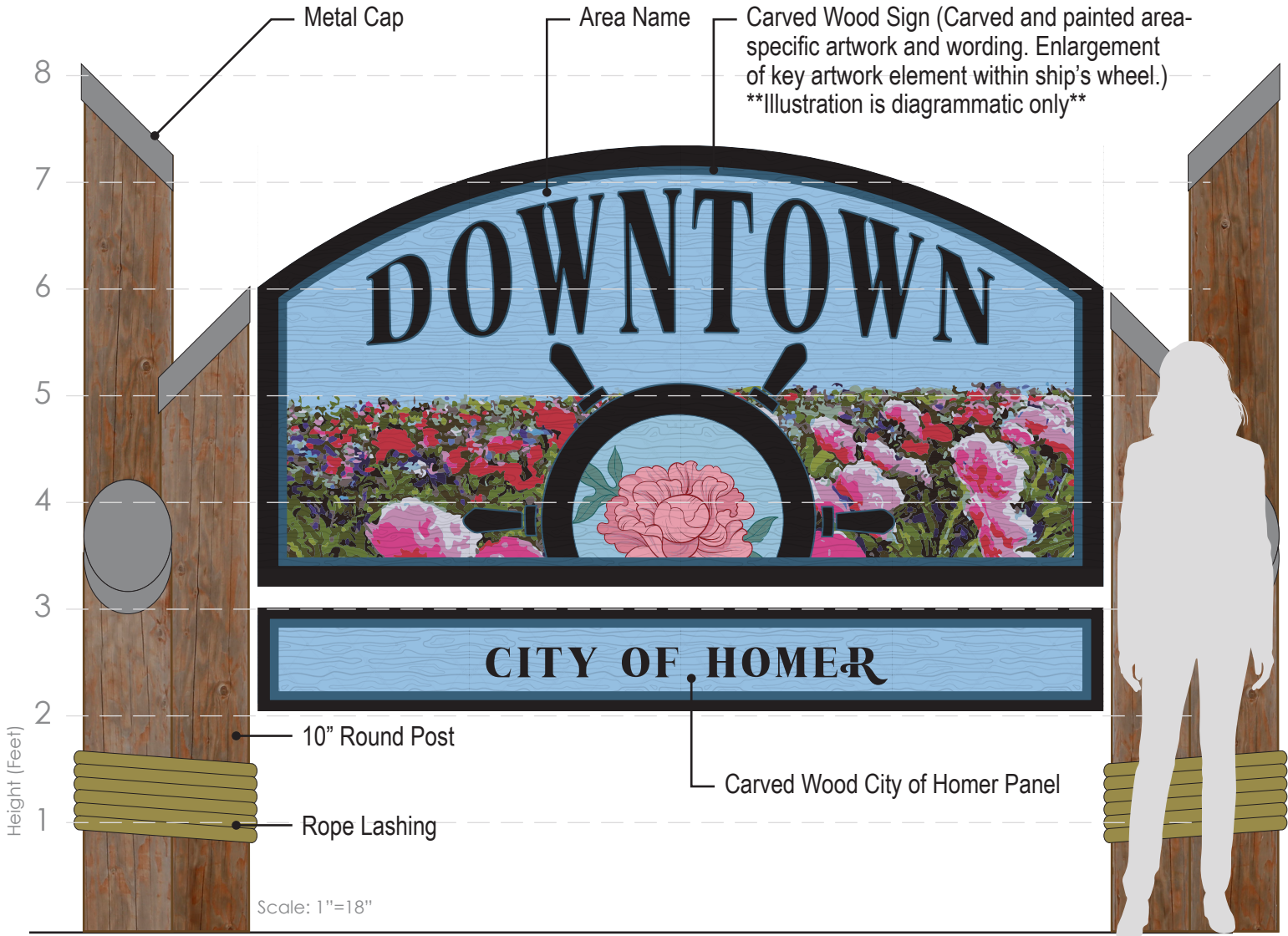

The Destination - Gateway Sign is used at key vehicular entry points to an 'identity' area within Homer. These will be for: Homer Spit, Downtown (shown), Old Town, Ocean Drive, and potential future locations.

The main and secondary sign panels (carved wood) are mounted to a steel frame that is attached to groupings of three timber posts (one grouping on either side of the panels).

The artwork for each sign location will be determined at the time of design and fabrication. The intent is that a conceptual design is procured, with a fabricator turning the design into a commercial sign product. While the conceptual design for each location will be different, the final products will be stylistically the same for consistency.

DIRECTIONAL - ROAD (ADOT&PF)

Pioneer Avenue and the Sterling Highway are Alaska Department of Transportation and Public Facilities (ADOT&PF) rights-of-way. Signage within these road corridors should prioritize using standard ADOT&PF sign types for directional purposes. Non-standard signs will need to meet ADOT&PF standards and their limitations.

There are three standard sign types:

- Road Guide Sign (green)
- RCIA - Recreational and Cultural Interest Area sign (brown)
- TODS - Tourist Oriented Directional Sign (blue)



The Directional - Road (ADOT&PF) is used to direct vehicular traffic. These require ADOT&PF permitting and design and construction need to meet ADOT&PF standards.

DIRECTIONAL - ROAD (HOMER)

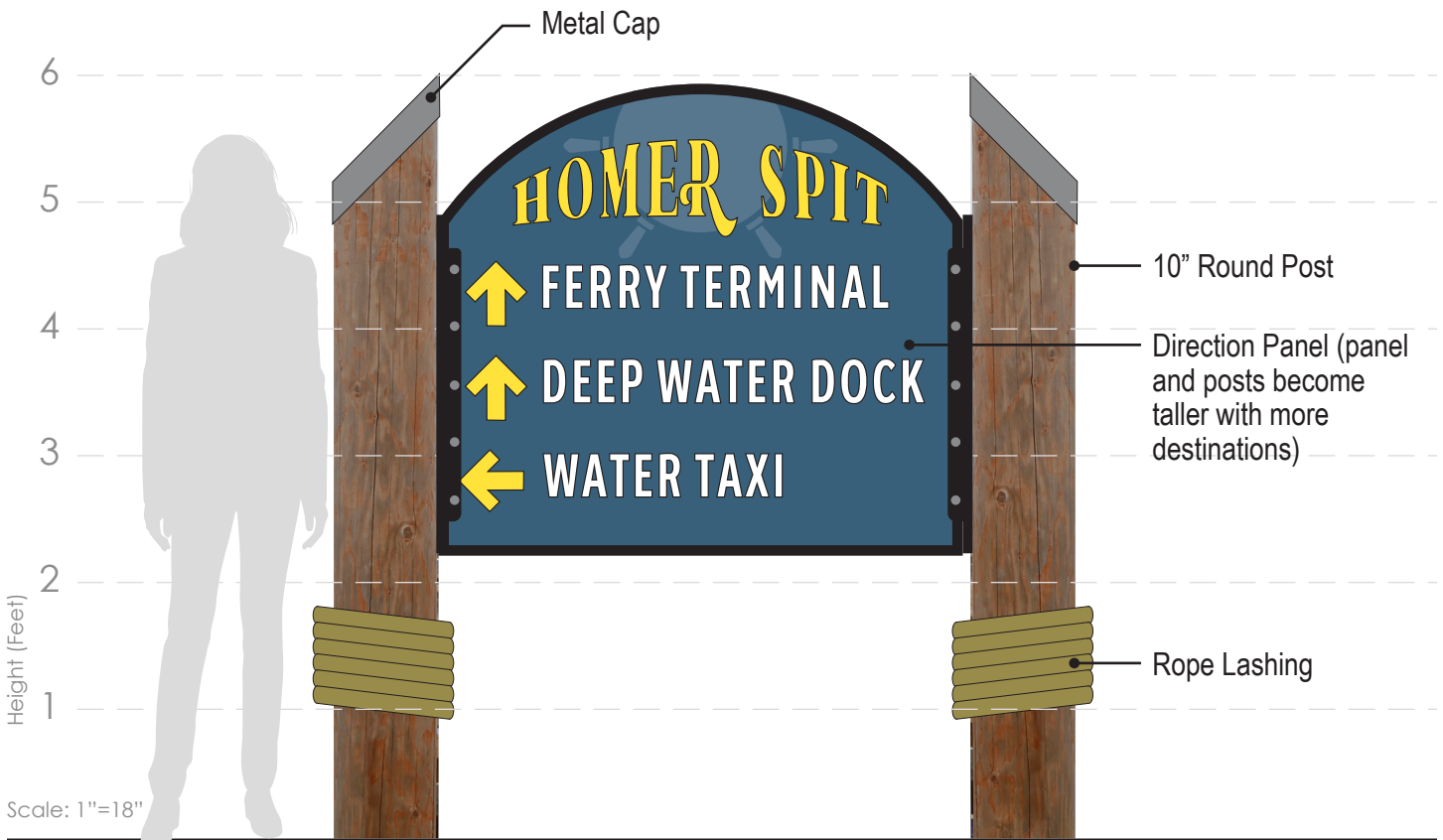

The Directional - Road (Homer) Sign is used on City of Homer roads to direct vehicular traffic to an area or specific destination. Use of these signs within ADOT&PF rights-of-way would require permitting, and potential re-design for safety requirements.

The main sign panel (high pressure laminate) is mounted to a steel frame attached to two timber posts.

INFORMATION (HOMER)

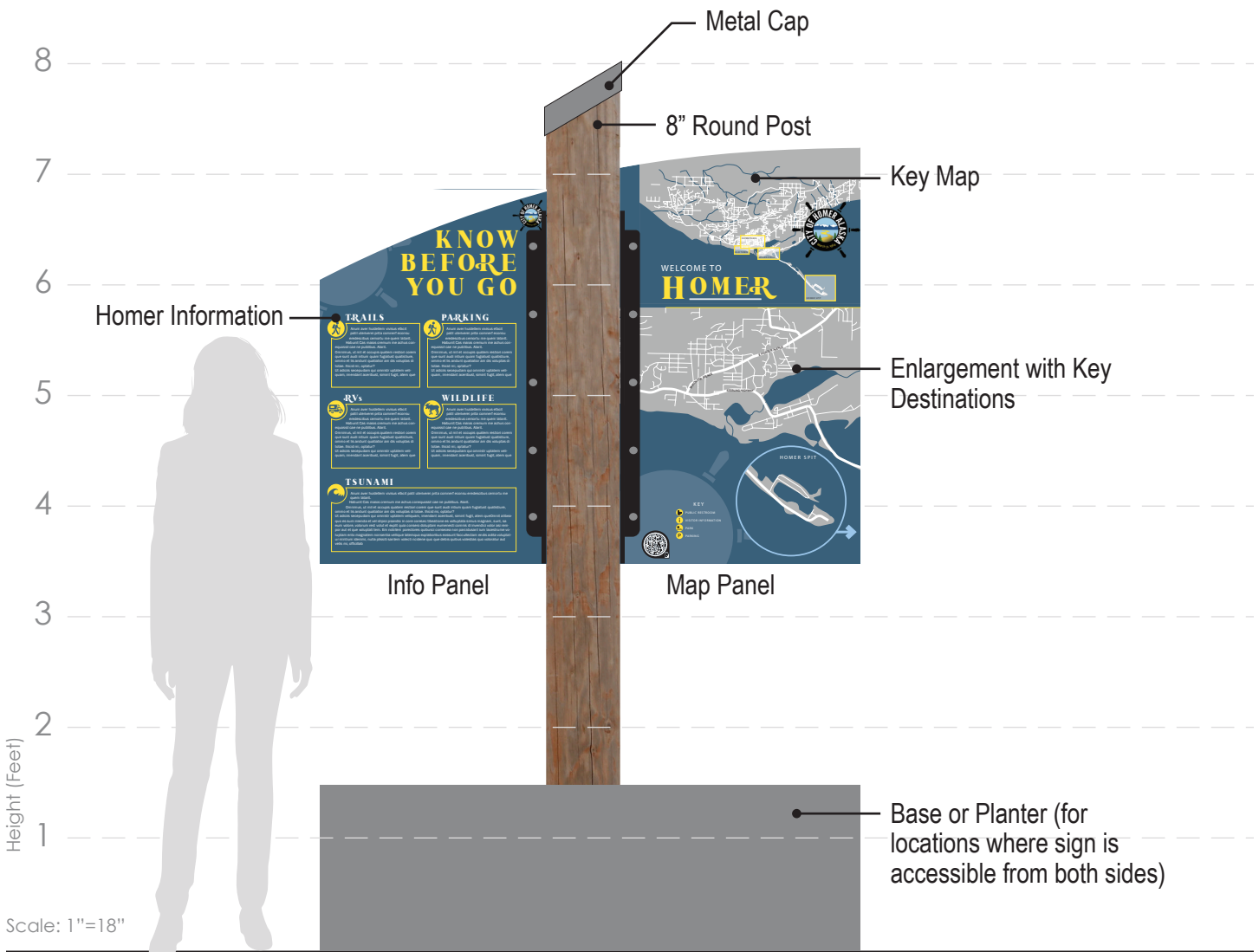

The Information (Homer) sign is used at key arrival locations to Homer. The purpose of this sign is to help people find and prepare themselves for destinations, prepare them with general information for how they will experience Homer, alert them to specific safety information (such as Tsunami), and possibly change or expand where they might go and what they might do during their time in Homer. The main signs include a map and information text. The supporting sign provides information to help shape their time in Homer, and may be different depending on the location and expected audience.

The sign panels (high pressure laminate) are mounted to steel frames attached to a single post.

INFORMATION (AREA)

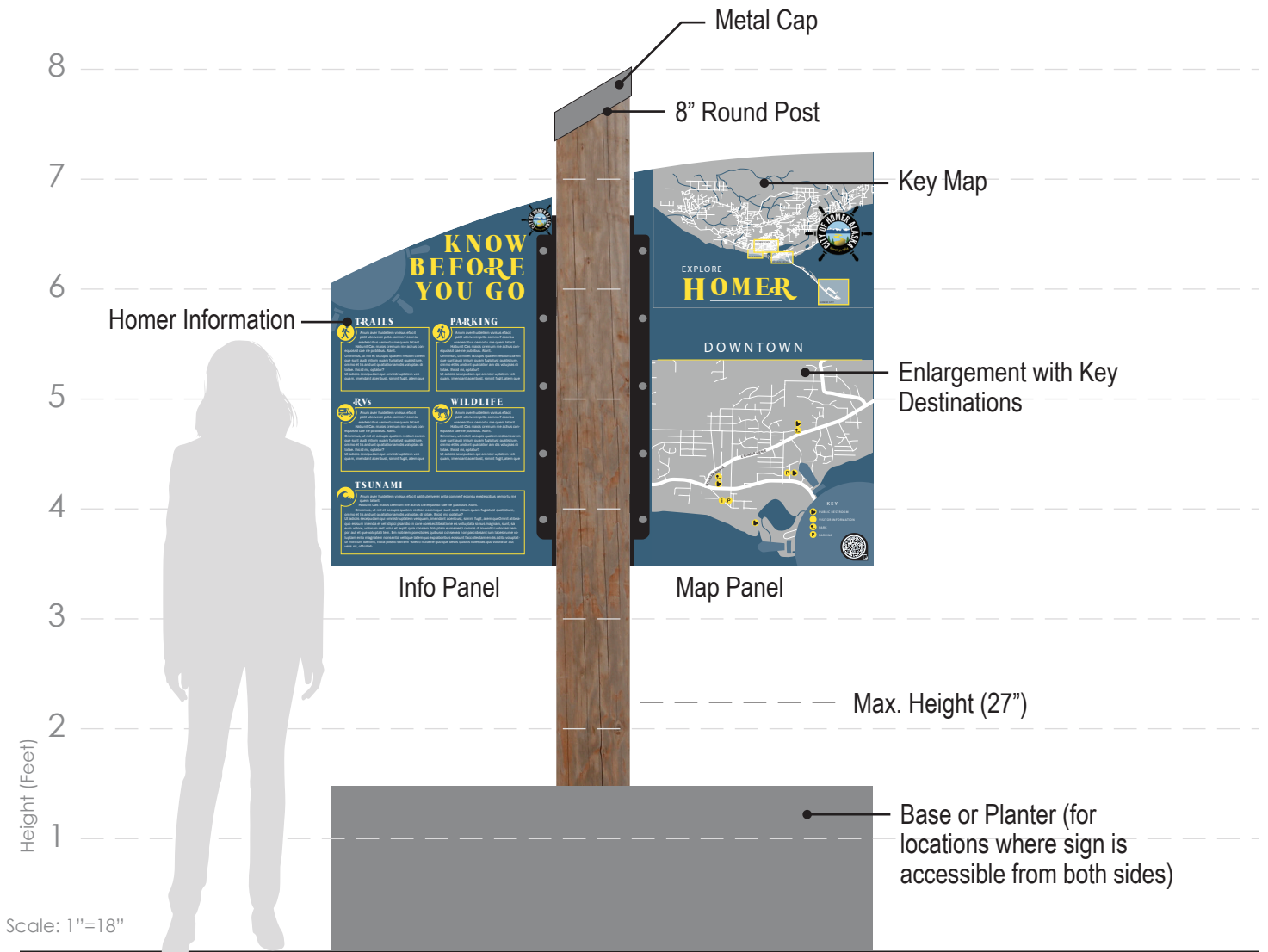

The Information (Area) sign is used at key arrival locations where people would benefit from a higher level of detail for the area. The goal is to encourage people to use non-motorized transportation to explore within the area, or move to other areas of Homer. The purpose of this sign is to help people navigate to specific destinations in the area, connect them to safe walking routes, and possibly change or expand where they might go and what they might do during their time in Homer. The main signs include a map and information text.

The sign panels (high pressure laminate) are mounted to steel frames attached to a single post.

DIRECTIONAL - POST

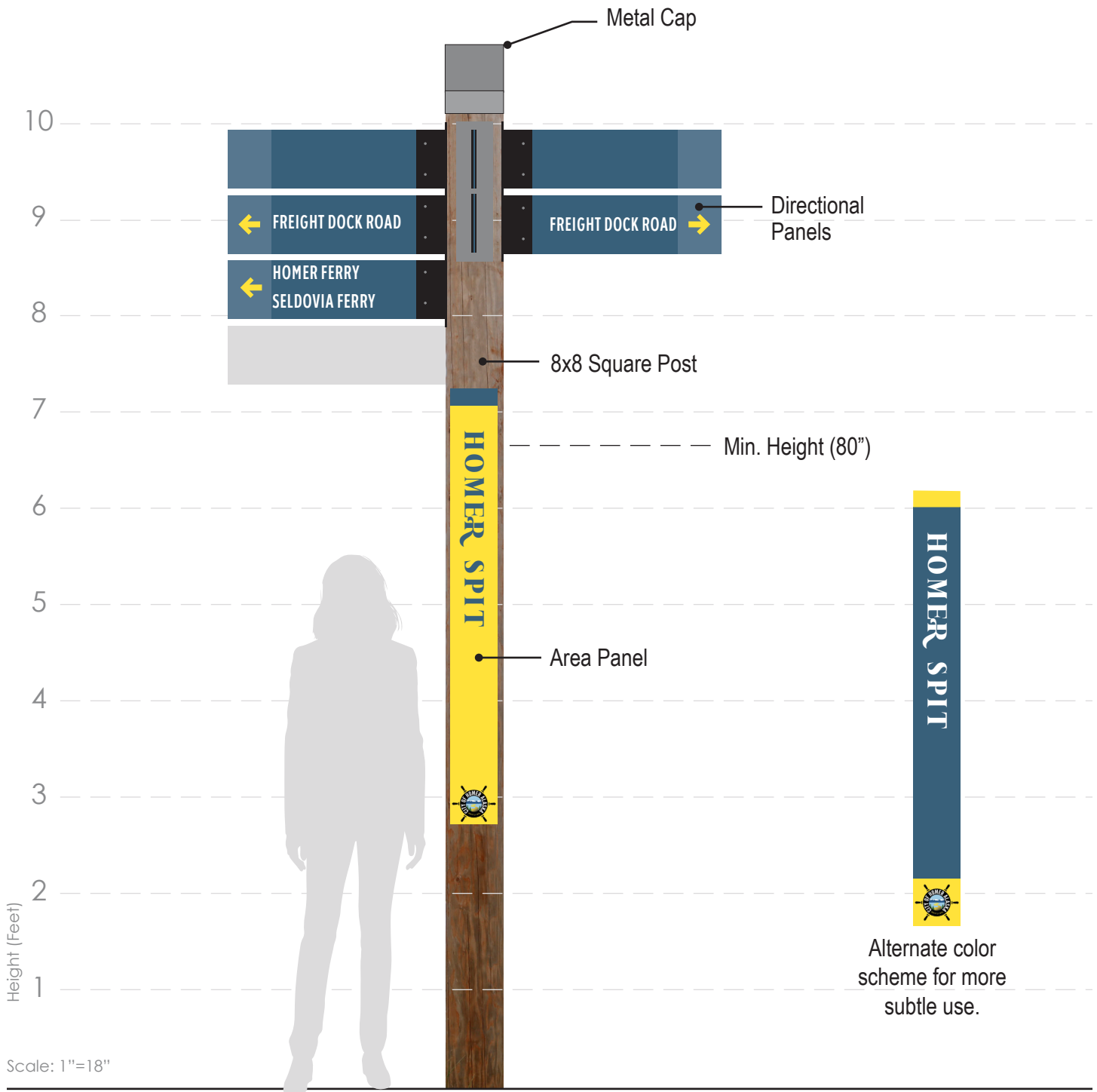

The Directional - Post Sign is used to provide directional information to pedestrians.

The sign panels (high pressure laminate) are mounted to steel frames attached to a single post, and include arrows to specific destinations.

DIRECTIONAL - BOLLARD

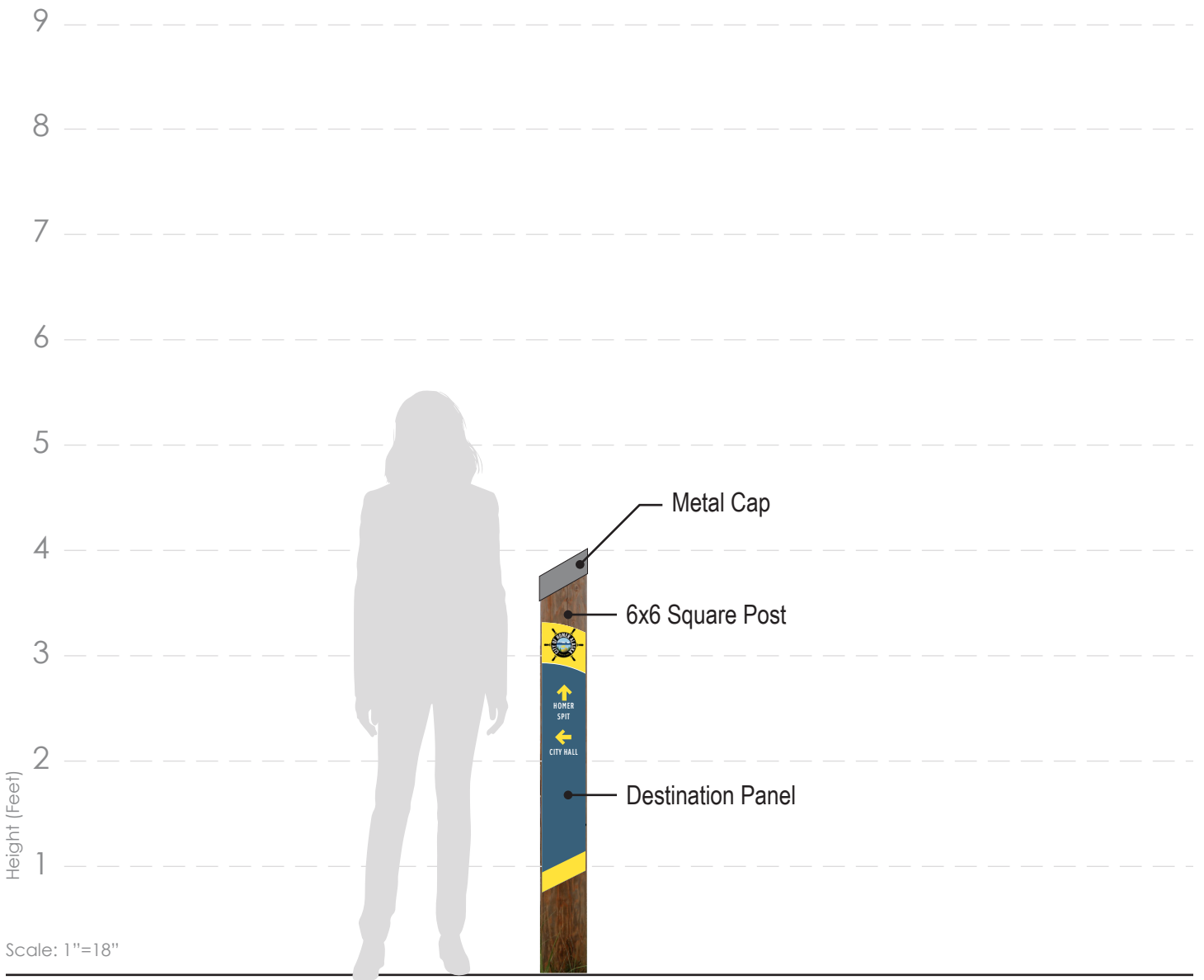

The Directional - Bollard is used to provide directional information to pedestrians.

The sign panel (high-pressure laminate) is mounted directly to the single wood post bollard.

DESTINATION - POST

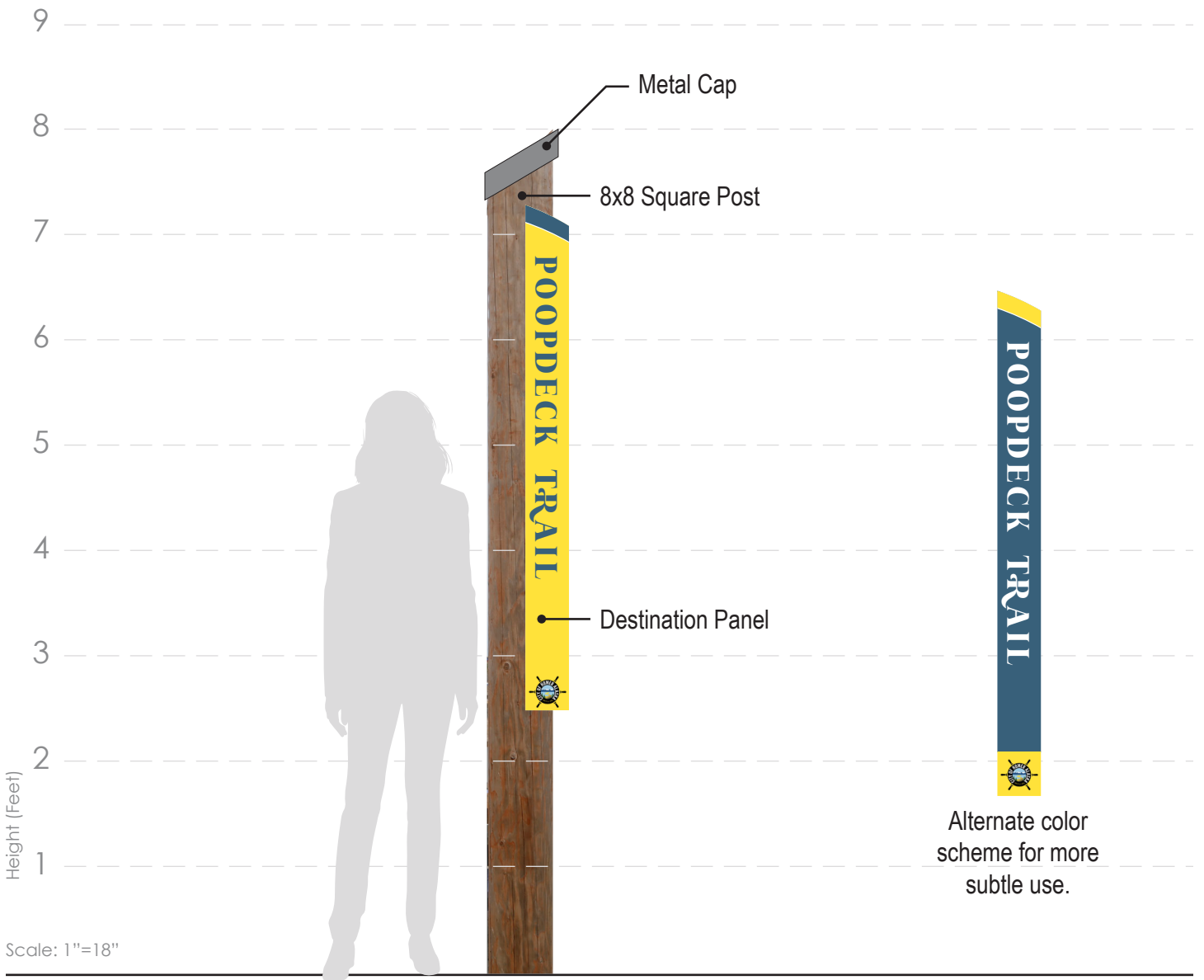

The Destination Sign is used to identify public locations (such as trailheads) when another sign type is not appropriate (i.e. park signs where there is an existing standard)

The sign panel (high-pressure laminate) is mounted directly to a single wood post.



SIGN DETAIL

DESTINATION - GATEWAY

Text and Graphics

Item	Dimensions	Description	Notes
Panel A-1	96" x 50 1/8"	Panel Composed of Laminated 4x6	Artwork Developed by Artist
Panel A-2	96" x 10"	Panel Composed of Laminated 4x6	
Area Lettering	Min. 8" Ht, max. 16" Ht, Rockabye All Caps	Carved into Panel A-1	Area Name, curved top and bottom
City of Homer Lettering	4" Ht, Rockabye All Caps	Carved into Panel A-2	City of Homer

Sign Layout

Note: Text, artwork, colors, and other information to be provided specific to each location.

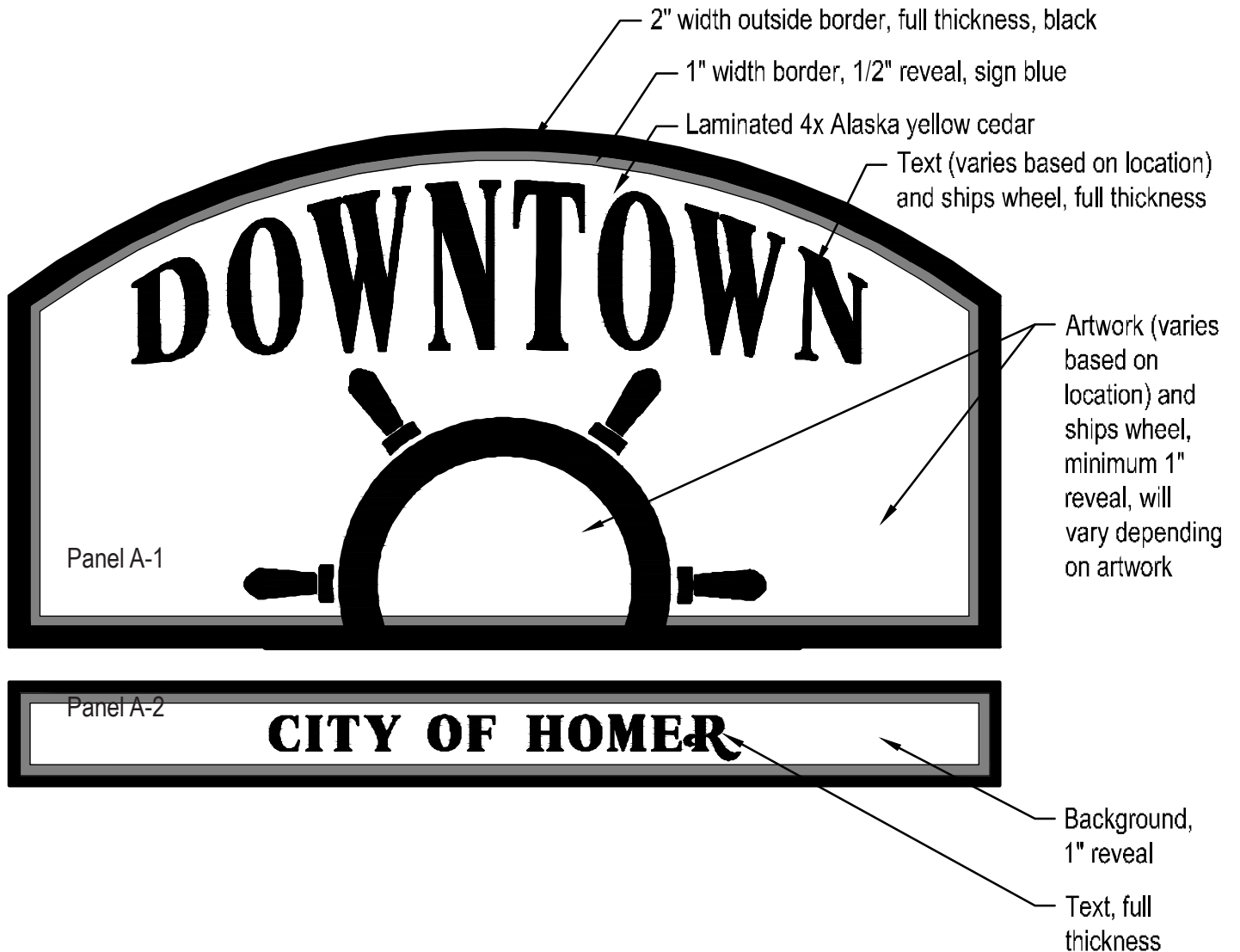

Plan

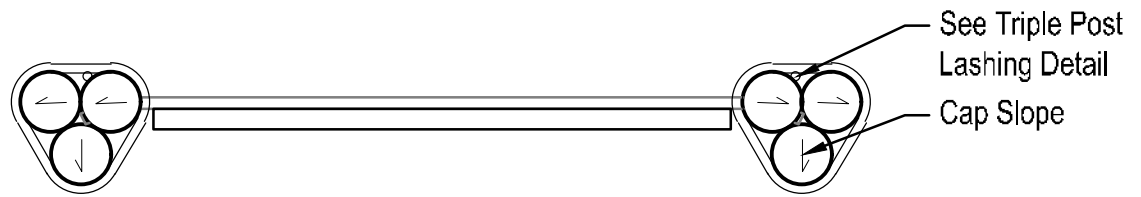

Rear Elevation

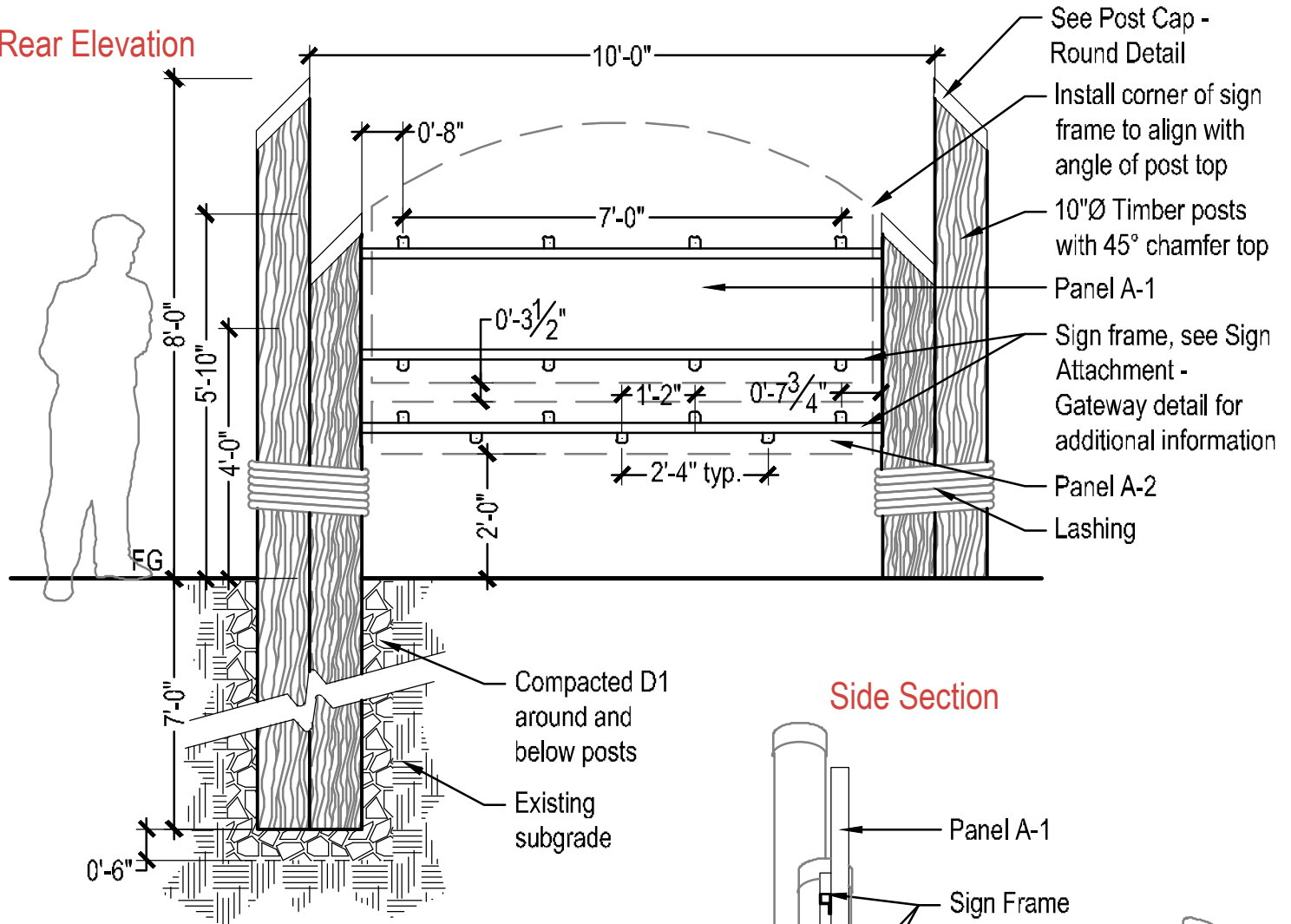

Side Section

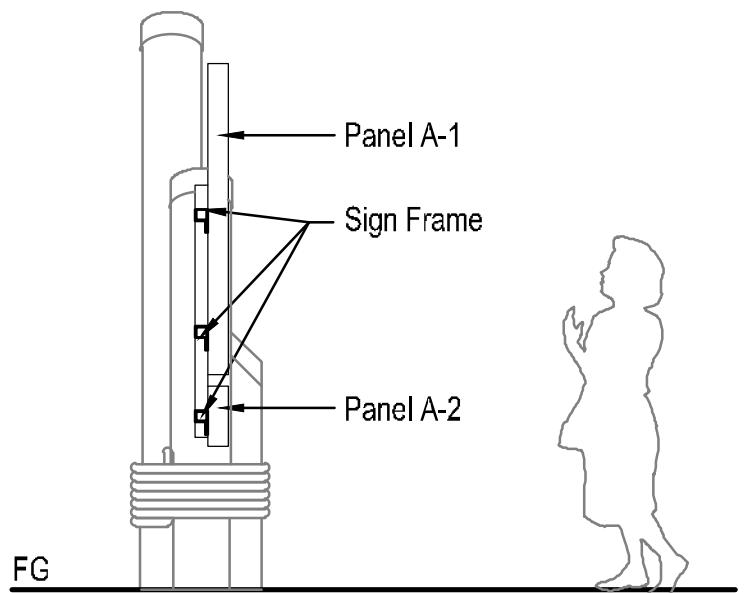

Scale: 3/8"=1'-0"

DIRECTIONAL - ROAD (HOMER)

Text and Graphics

Item	Dimensions	Description	Notes
Panel B-1	54" x 45.625"	3/4" High Pressure Laminate	
Area Lettering	Min. 4" Ht, max 8" Ht, Rockabye All Caps	Printed on Panel B-1	Area Name, curved top and bottom
Destination Lettering	4" Ht, Roadgeek All Caps	Printed on Panel B-1	Destinations
Arrow	6" Ht.	Printed on Panel B-1	Per InDesign Template

Sign Layout

Dimensions are shown for information only. Panels are to be ordered with camera-ready artwork generated using InDesign template. This template includes locations for holes to be drilled.

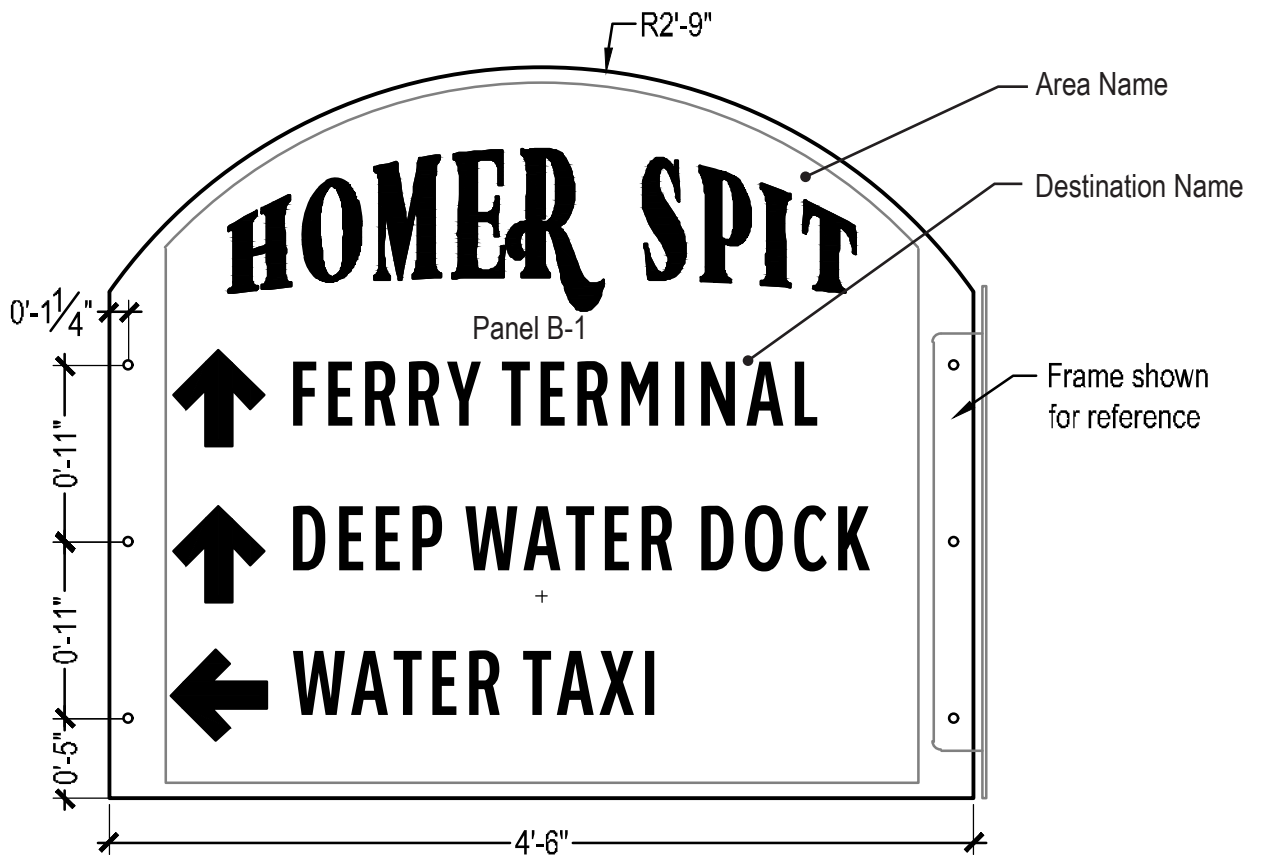

Scale: 1"=1'-0"

Plan

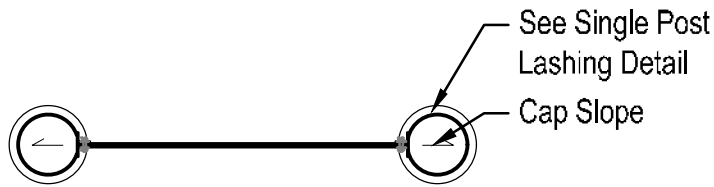

Rear Elevation

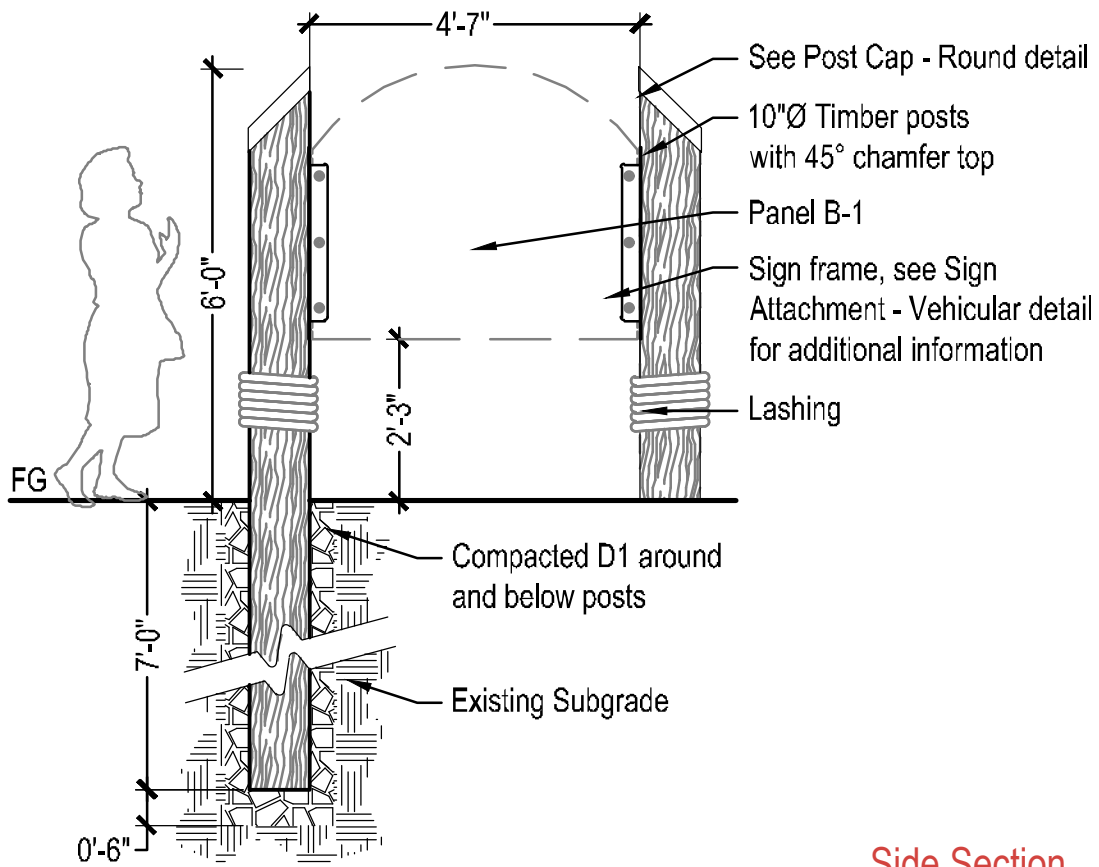

Side Section

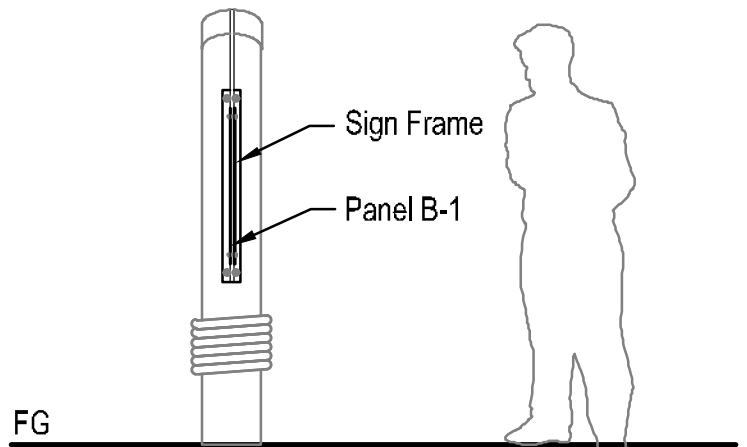

Scale: 3/8"=1'-0"

INFORMATION - HOMER & AREA

Text and Graphics

Item	Dimensions	Description	Notes
Panel C-1	26" x 40.5"	3/4" High-pressure laminate	Cut line
Panel C-2	26" x 45"	3/4" High-pressure laminate	Cut line
Lettering & Graphics			Per InDesign Template

Sign Layout

Dimensions are shown for information only. Panels are to be ordered with camera-ready artwork generated using InDesign template. This template includes locations for holes to be drilled.

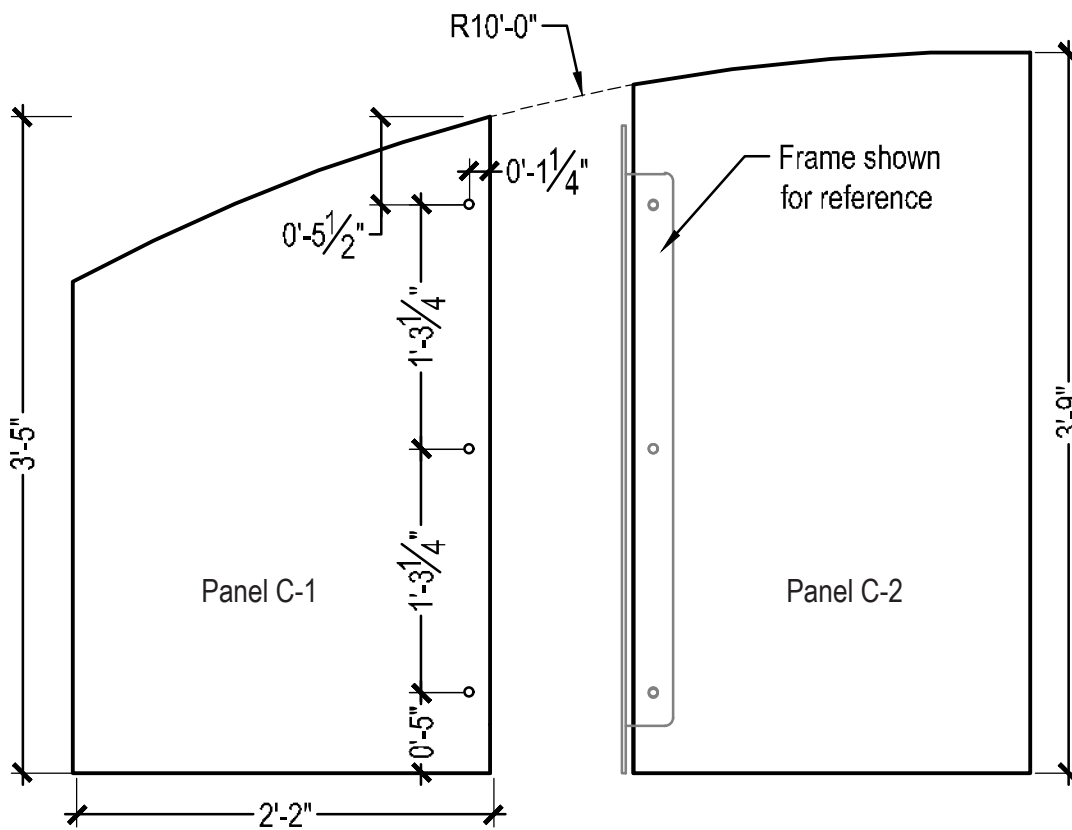

Scale: 1"=1'-0"

Plan

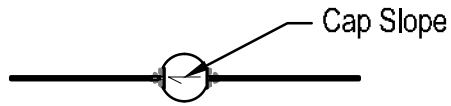

Front Elevation

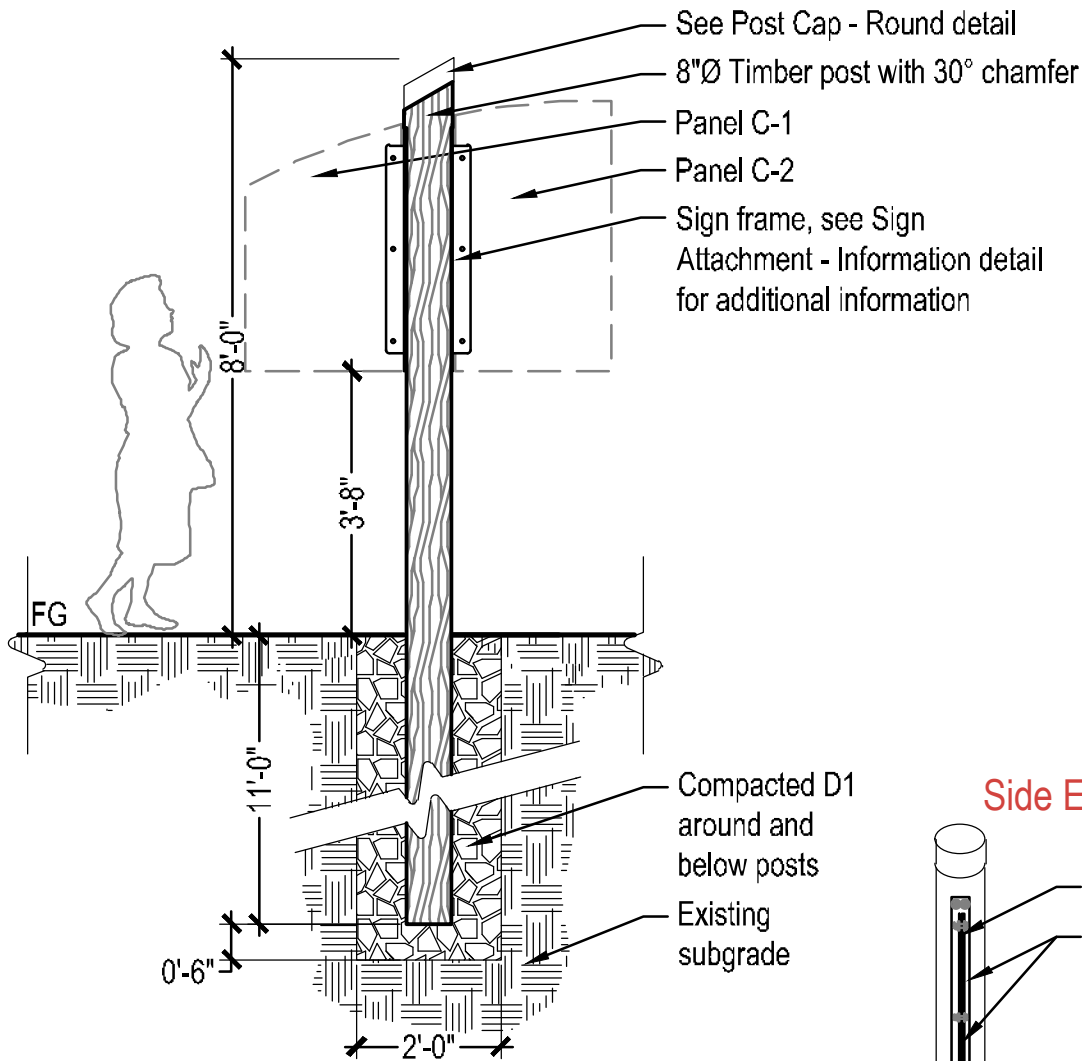

Side Elevation

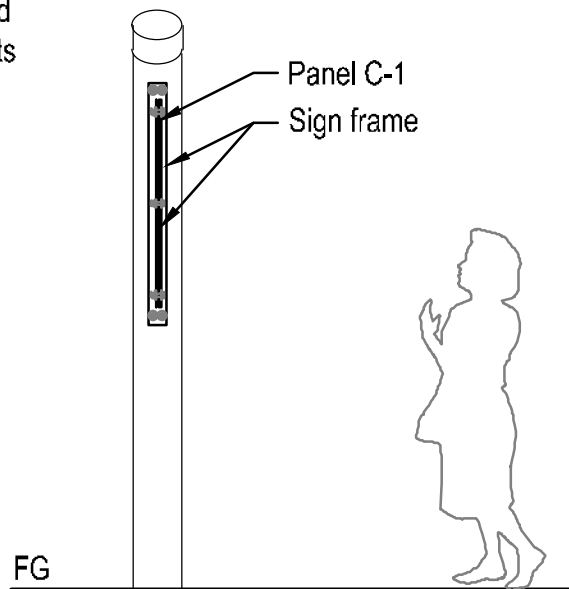

Scale: 3/8"=1'-0"

DIRECTIONAL - POST

Text and Graphics

Item	Dimensions	Description	Notes
Panel D-1	30" x 8"	1/4" Digitally Fused Aluminum	Destination
Panel D-2	54" x 6.5"	1/2" High-pressure laminate	Area Name
Destination Lettering	2.75" Ht, Roadgeek All Caps	Printed on Panel D-1	Destination Name(s)
Area Lettering	4.75" Ht, Rockabye All Caps	Printed on Panel D-2	Area Name
Arrow	3" Ht	Printed on Panel D-1 and D-2	

Sign Layout

Dimensions are shown for information only. Panels are to be ordered with camera-ready artwork generated using InDesign template. This template includes locations for holes to be drilled.

Area Name Panel (D-2)

Direction Panel - Double Destination (D-1)

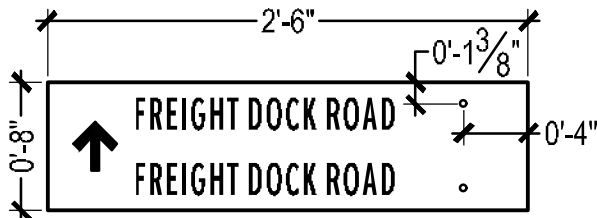

Direction Panel - Single Destination (D-1)

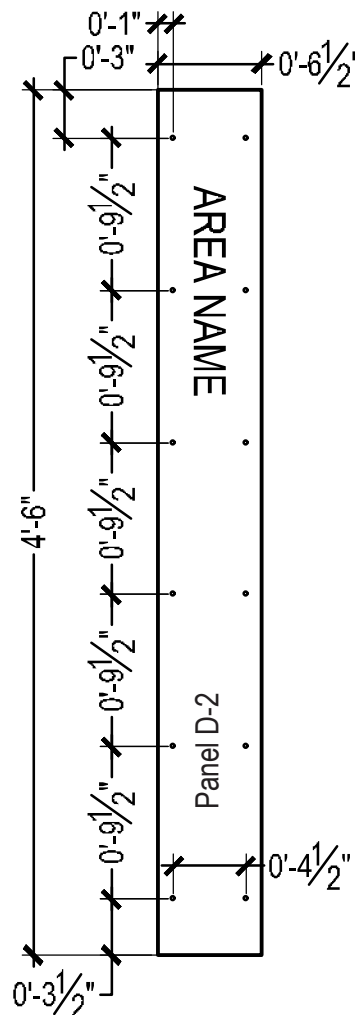
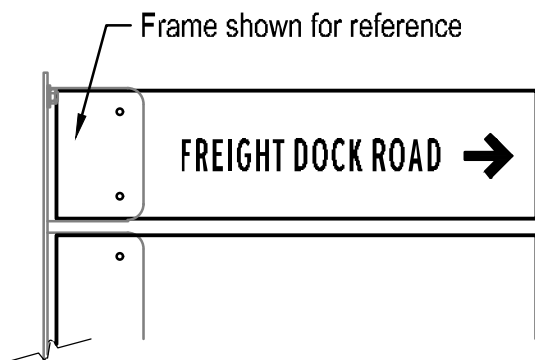

Scale: 1"=1'-0"

Directional Post - Cont'd

Plan

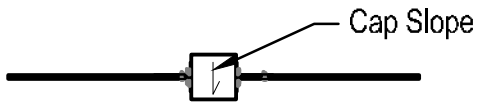

Front Elevation

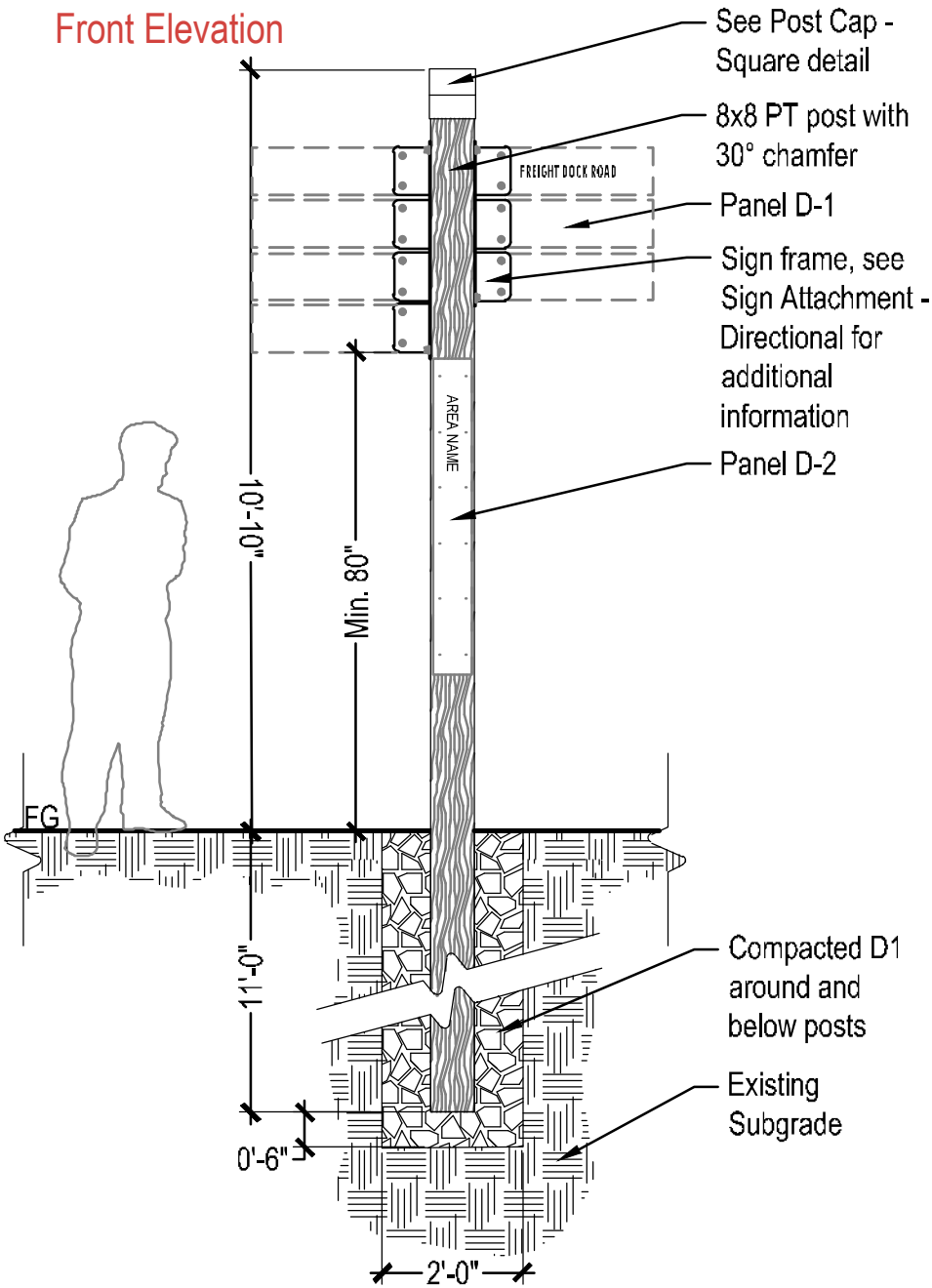

Side Elevation

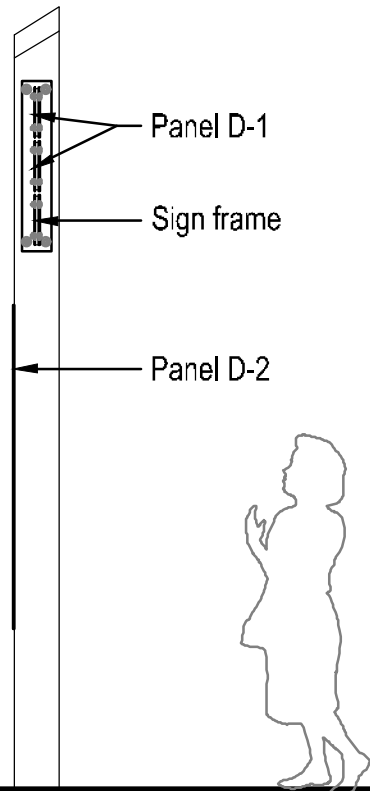

Scale: 3/8"=1'-0"

FG

DIRECTIONAL - BOLLARD

Text and Graphics

Item	Dimensions	Description	Notes
Panel E-1	4.5" x 31"	1/2" High-pressure laminate	Cut line
Destination Lettering	1" Ht, Roadgeek All Caps	Printed on Panel E-1	Destination
Arrow	1.75" Ht	Printed on Panel E-1	

Sign Layout

Dimensions are shown for information only. Panels are to be ordered with camera-ready artwork generated using InDesign template. This template includes locations for holes to be drilled.

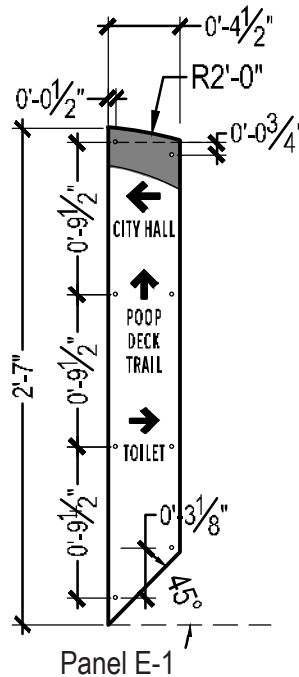

Scale: 1"=1'-0"

Front Elevation

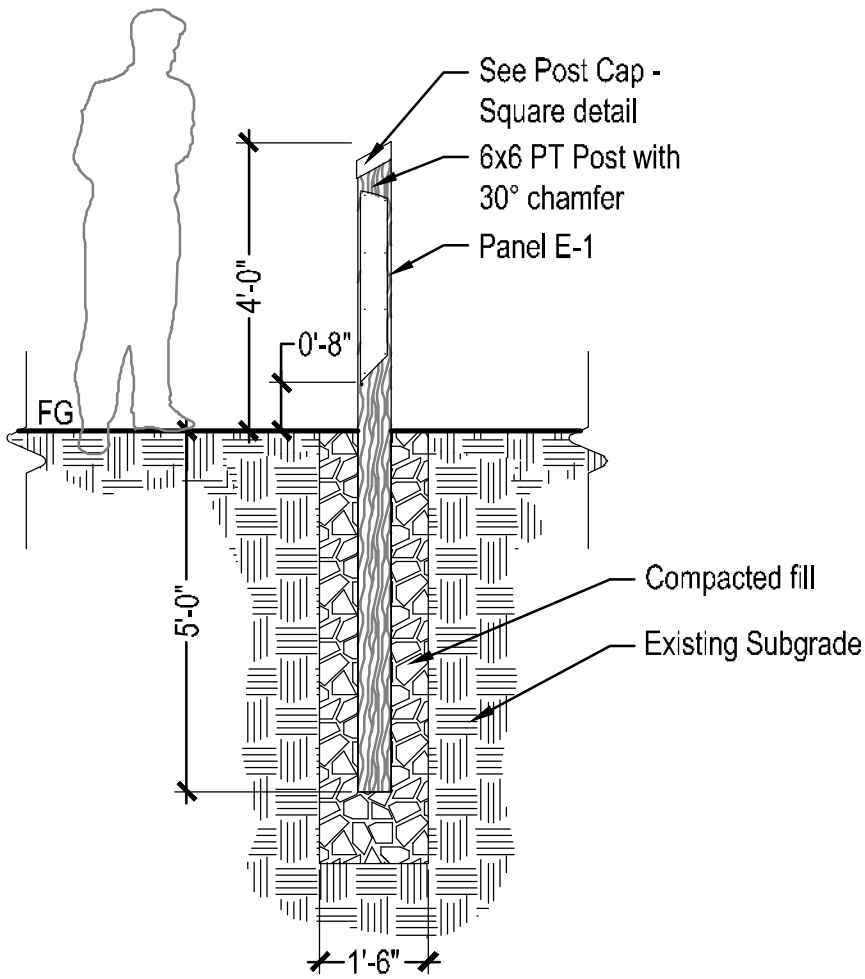

Side Elevation

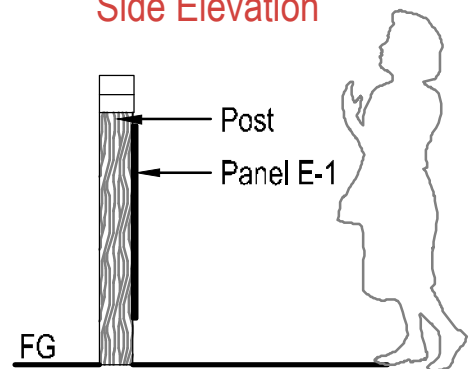

Scale: 3/8"=1'-0"

Front Elevation

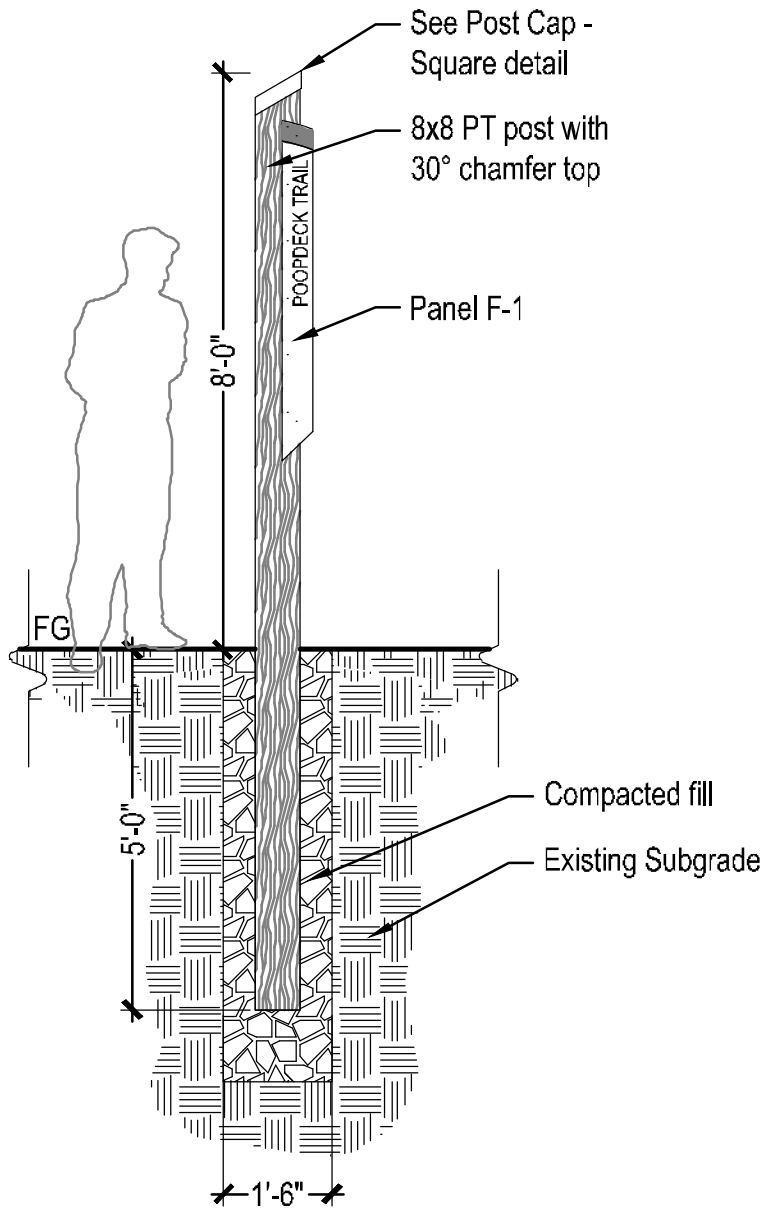

Side Elevation

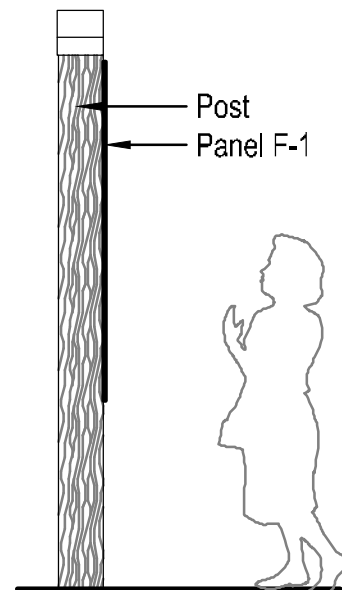

Scale: 3/8"=1'-0"



SPECIFICATIONS & DETAILS

TYPEFACE AND COLORS

Typeface

Rockabye

A B C D E F G H I J K L M N O P Q R S T U V W X Y Z

0 1 2 3 5 6 7 8 9

Franklin Gothic Book regular

A B C D E F G H I J K L M N O P Q R S T U V W X Y Z

a b c d e f g h i j k l m n o p q r s t u v w x y z

0 1 2 3 5 6 7 8 9

Roadgeek 2005 Series 1B

A B C D E F G H I J K L M N O P Q R S T U V W X Y Z

0 1 2 3 5 6 7 8 9

Colors

Pantone 5405CP

Sign Blue



Pantone 7404CP

Sign Yellow



Pantone 423C

Sign Grey



Pantone 658CP

Sign Light Blue



**80%
TINT**

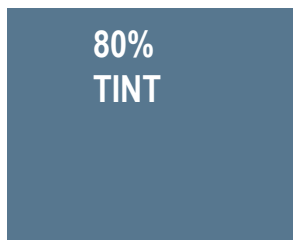

SIGN GRAPHICS

City of Homer Logo

Use of the City of Homer logo is guided by the City of Homer Logo and Graphic Use Standards Manual.



Map Icons

The map icons are used on the maps to show key destinations or information to assist in route planning.



Public Toilet



Public Parking



Trailhead



Information



Civic Destination



Crosswalk



Park

Arrows



QR Code



STANDARD SPECIFICATIONS

Materials

Metals, General:

- Provide materials with smooth, flat surfaces without blemishes. Do not use materials with exposed pitting, seam marks, roller marks, rolled trade names, or roughness.
- Steel, aluminum or stainless steel will be detailed in accordance with standard industry practice and suitable for the use intended.
- Remove tool and die marks and stretch lines.
- Fasteners and connectors used together will be compatible.

Gateway Panels:

- Gateway Panels will be composed of laminated 4x western red cedar (#1 grade or better). Lamination will be done with an exterior grade/waterproof polyvinyl acetate (PVA) glue such as Titebond III, or an accepted equivalent. After carving (hand and/or CNC) the surfaces will be clean and free of dust and all other foreign substances and treated as appropriate to remove mill glaze.
- Prime panels all sides with a high quality exterior oil-based primer, applied per manufacturer's recommendations. A suitable product is Sherwin Williams Exterior Oil-Based Wood Primer. Recommended film thickness is expected to be: 4 mils wet and 2.3 mils dry.
- Sign information and artwork to be applied with a compatible high quality oil-based paint, applied per manufacturer's recommendations. A suitable product is color tinted Sherwin Williams SWP Exterior Oil Base Gloss Paint. Recommended film thickness is expected to be: 4 mils wet and 2.1 mils dry. Paint to be applied as necessary to achieve consistent colors.
- Completed painted sign to be top-coated with a minimum of 2 coats of satin finish exterior urethane, applied per manufacturer's recommendations. A suitable product is Minwax Helmsman Spar Urethane.

High-Pressure Laminate (HPL) Panels:

- Custom High-Pressure Laminate material will be composed of the required layers of FSC Certified phenolic resin impregnated brown or black kraft filler paper to produce panels of thickness specified, surfaced by a layer of melamine overlay, graphics imaged on saturation grade paper with UV resistant pigment based process color inks, and with an optically clear UV overlay that will resist no less than 99% of all sunlight and UV rays, as well as provides a graffiti resistant surface that allows for removal with standard cleaners.
- Warranty: 10-year full warranty against fading, delaminating or other material defect from date of substantial completion. Warranty is not to be pro-rated, and is inclusive of shipping costs.
- Finish: Matte

Dye-Sublimated Aluminum Panels

- Dye-Sublimated Aluminum Panels will be composed of 1/4" thickness 5052 aluminum plate, with holes coordinated with other sign components. Graphics will be applied through the application of a dye sublimated image to powder coated aluminum, topped with Automotive UV clear-coat.
- Warranty: 2-year full warranty against fading, delaminating or cracking. Warranty is not to be pro-rated, and is inclusive of shipping costs.

Standard Specifications - Cont'd

Round Lumber Posts:

- Alaska Yellow Cedar: #1 grade or better, kiln dried, free of knots, solid stock of species indicated.

Square Lumber Posts:

- Alaska Yellow Cedar: #1 grade or better, kiln dried, free of knots, solid stock of species indicated.
- Surfaced smooth on four sides with eased corners

Post Caps:

- Post caps shall be fabricated from 6061 or 5052 aluminum plate. Contractor is responsible to dimension and fabricate caps to fit snugly on posts, with secure attachment with fasteners as detailed.

Attachment Frames:

- Attachment frames shall be fabricated using A36 Steel Plate and ASTM A500 Steel Tubing

Footings

- Posts are set into compacted D1 gravel
- Footing depth varies per sign application, see individual sign type.

Finishes

Metals:

- General: Polished, sanded, or otherwise finished; smooth all surfaces, free from burrs, barbs, splinters, and sharpness; all edges and ends rolled, rounded, or capped.
- Aluminum: Mill finish.
- Metal: Mill finish.

Coatings and Sealers

- Steel Coating: Urethane Alkyd Enamel Primer and Paint: Black colored, matte finish, two part application, primer and finish, for exterior steel applications. Products include Benjamin Moore, Super Spec HP-P23 Primer and Benjamin Moore, Super Spec HP-P22 Finish, or approved equivalent.

Hardware

General:

- Type 304 stainless-steel fasteners, commercial quality, tamper-proof, vandal and theft resistant, for exterior use (unless otherwise noted)

Fabrication

- Form to required shapes and sizes with true, consistent lines, and angles.
- Cut, drill, and punch metals cleanly and accurately. Remove burrs and ease edges to a radius of approximately 1/32 inch, unless otherwise indicated. Remove sharp or rough areas on exposed surfaces.
- Form exposed work true to line and level with accurate angles and surfaces and straight edges.
- Cut and drill metal fabrications as indicated to receive finish hardware, screws, and similar items.
- Provide for anchorage of type indicated; coordinate with supporting structure. Space anchoring devices to secure metal fabrications rigidly in place and to support indicated loads.

Standard Specifications - Cont'd

Examination

- Examine areas and conditions for compliance with requirements for correct and level finished grade, mounting surfaces, installation tolerances, and other conditions affecting performance.
- Proceed with installation only after unsatisfactory conditions have been corrected.

Installation

- Comply with manufacturer's written installation instructions for sign panels, unless more stringent requirements are indicated.
- Verify the layout, dimensions and attachment of all sign components prior to installation. Notify the Owner of any discrepancies.
- Stake locations of signs as indicated on Drawings. Adjust locations when requested and obtain Owner acceptance of layout before installing. Make minor adjustments as required.
- Field verify the location of all sign components and layout and dimensions for installation of signs. Owner to approve location of all signs prior to installation.
- Install signs level, plumb, true, and securely anchored at locations indicated on Drawings.
- Post Setting: Verify that posts are set plumb and are aligned and at correct height, spacing, and orientation. Hold posts in position during placement and finishing operations until adjacent fill is fully placed and compacted.
- Assemble sign components as indicated on Drawings.
- All threaded anchoring and fasteners to receive thread-lock during installation.

Cleaning

- After completing sign installation, inspect components. Remove spots, dirt, and debris. Repair damaged finishes to match original finish or replace component.

Typical Abbreviations

COH	City of Homer	PSI	Pounds per Square Inch
TYP	Typical	PCF	Pounds per Cubic Foot
CL	Center Line	SF	Square Foot
Ht	Height	Ft	Foot
w/	With	UON	Unless otherwise noted
MIN	Minimum	CHP	Chapter
MAX	Maximum	ACI	American Concrete Institute
HPL	High-Pressure Laminate	ASTM	American Society for Testing & Materials
IBC	International Building Code		
UV	Ultraviolet		
MI	Miles		
SS	Stainless Steel		
PSF	Pounds per Square Foot		

SIGN FRAME AND ATTACHMENT DETAILING

Gateway - Sign Frame and Attachments

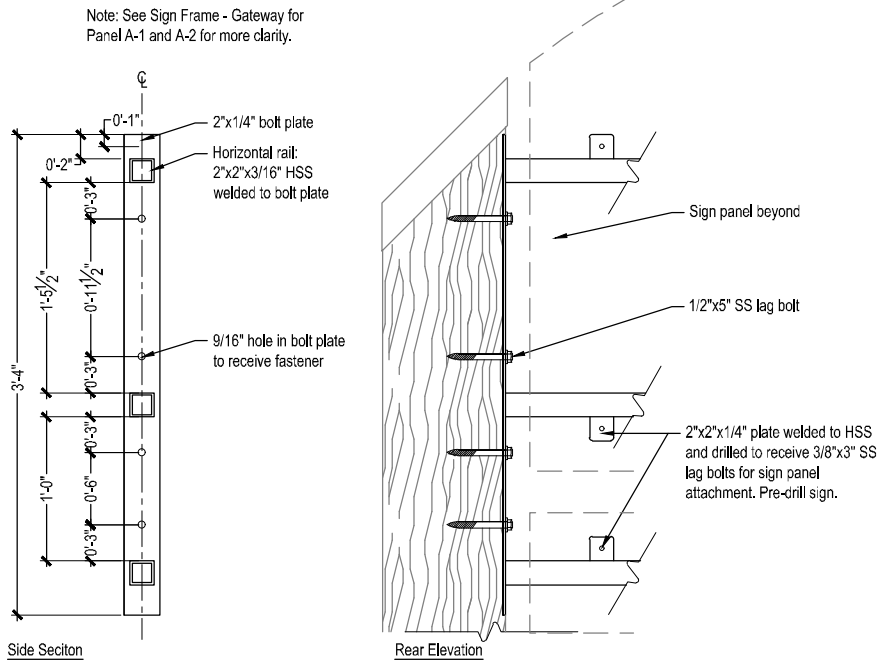

Scale: 3/4"=1'-0"

Wayfinding Vehicular - Sign Frame and Attachments

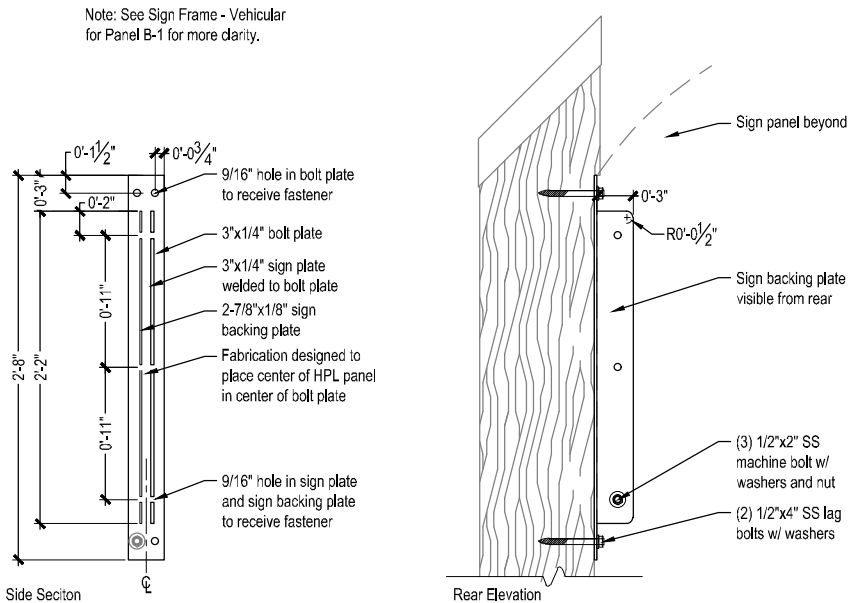

Scale: 3/4"=1'-0"

Sign Frame and Attachment Detailing - Cont'd

Orientation - Sign Frame and Attachments

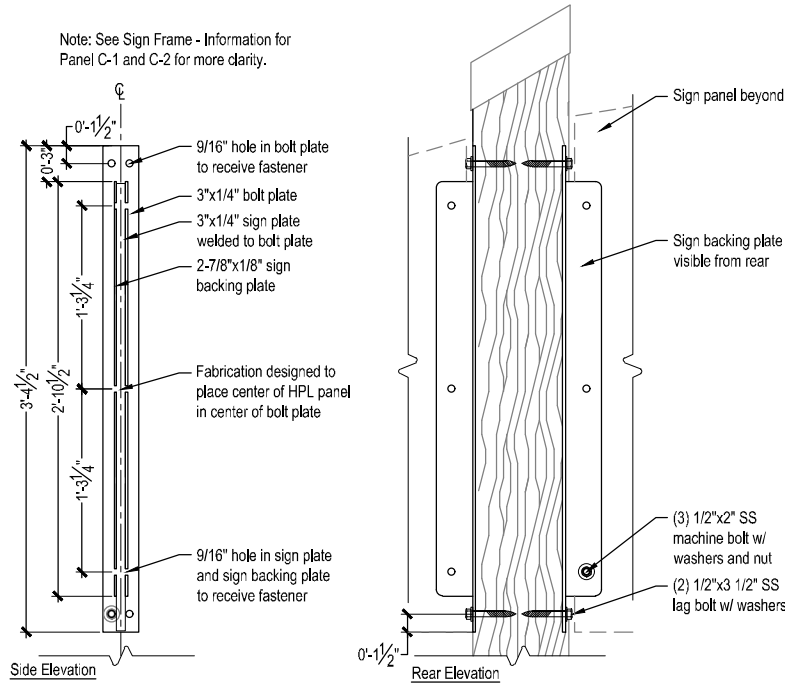

Scale: 3/4"=1'-0"

Direction Post - Sign Frame and Attachments

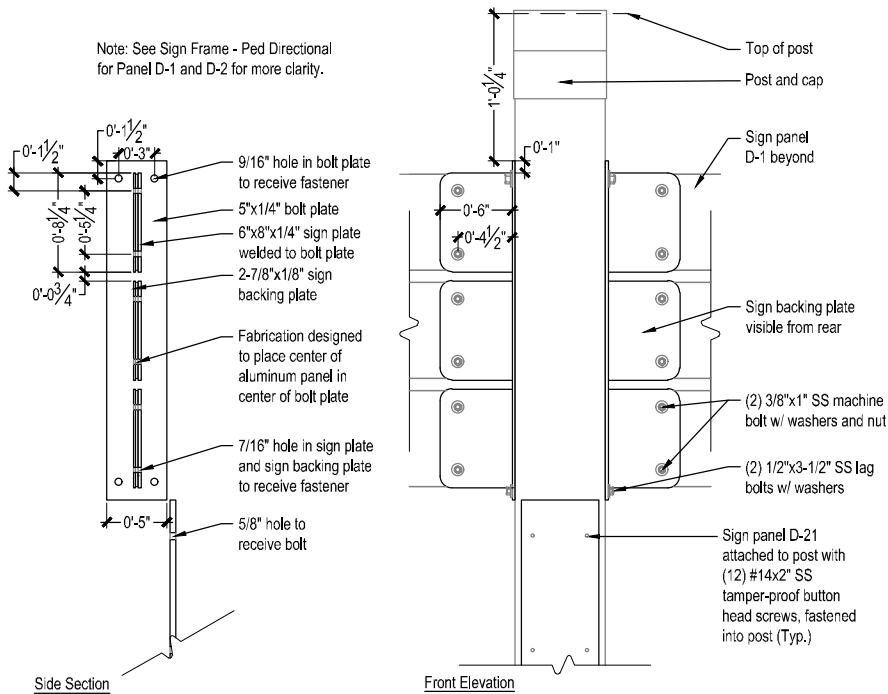

Scale: 3/4"=1'-0"

Sign Frame and Attachment Detailing - Cont'd

Direction Bollard - Sign Attachment

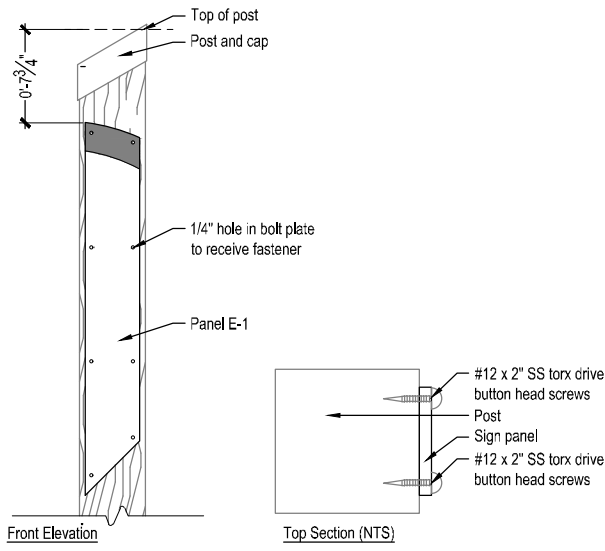

Scale: 3/4"=1'-0"

Destination Post - Sign Attachment

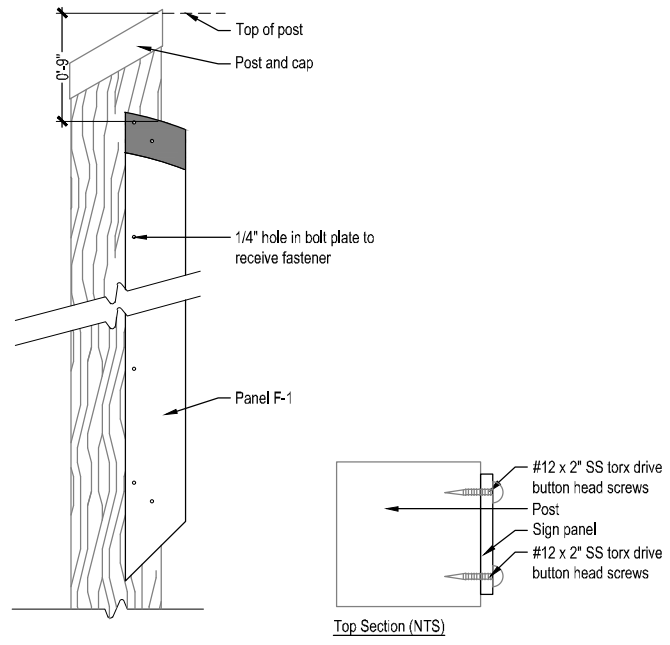

Scale: 3/4"=1'-0"

Sign Frame and Attachment Detailing - Cont'd

Gateway Sign Frame - Top Section

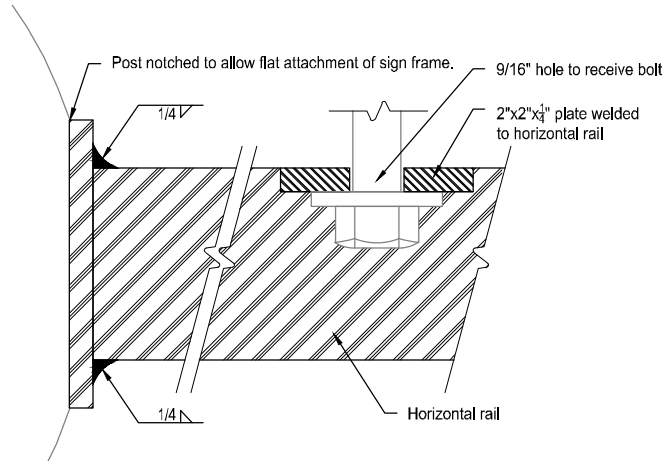

Vehicle Wayfinding and Orientation Sign Frames - Top Section

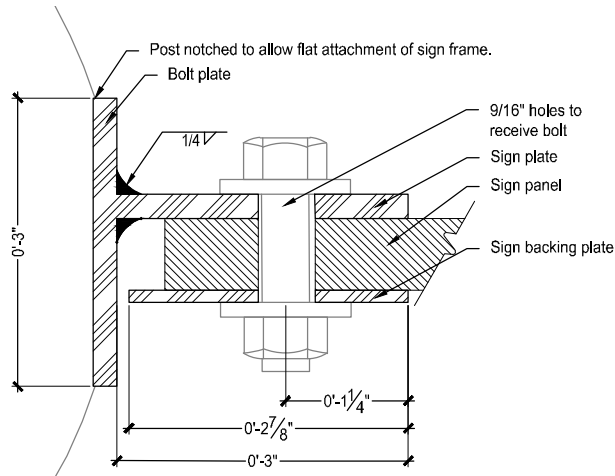

Directional Post Frame - Top Section

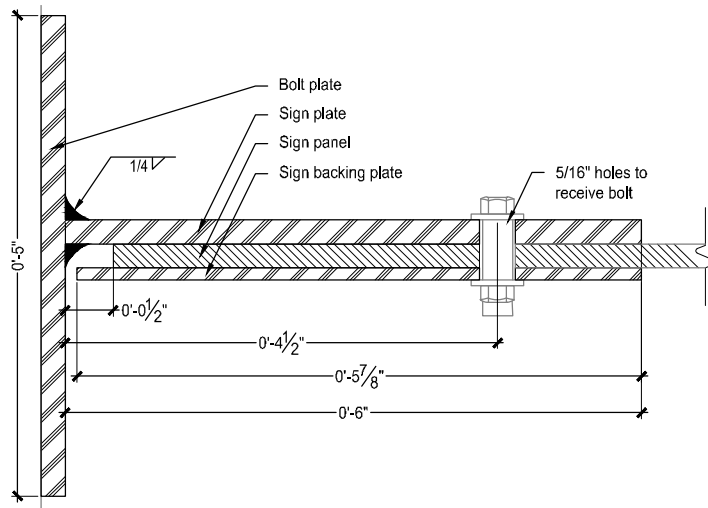

POST CAP AND LASHING DETAILING

Post Cap Details

Square Post

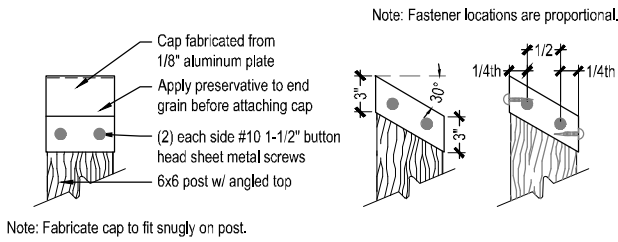

Round Post

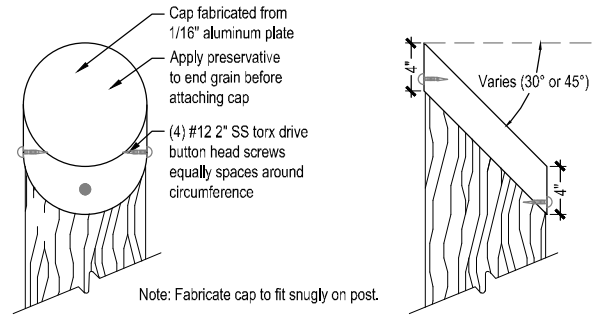

Scale: 3/4"=1'-0"

Lashing Details

Triple Post

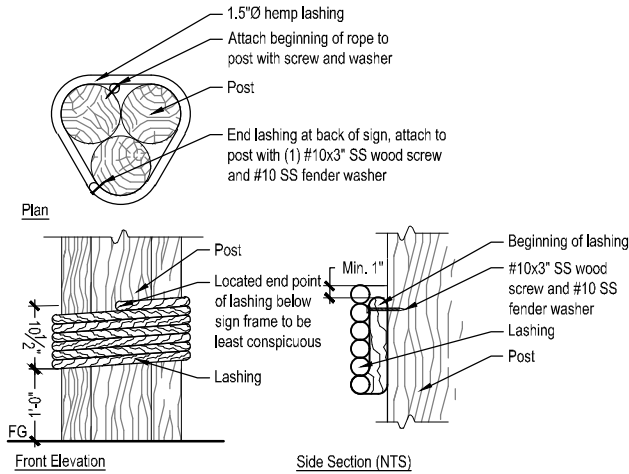

Single Post

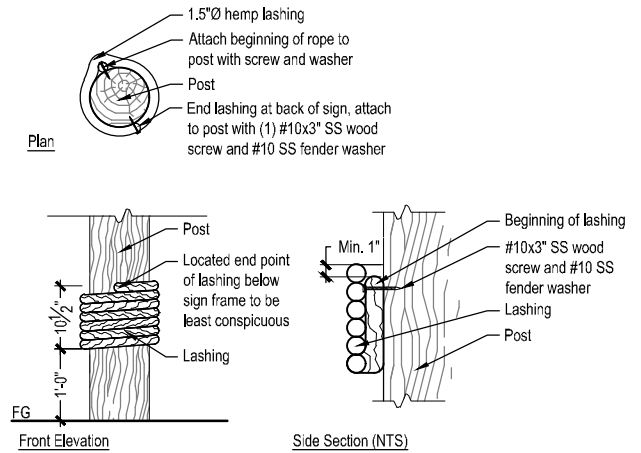

Scale: 1/2"=1'-0"



COST ESTIMATES

COST ESTIMATES

December 2021

Destination - Gateway

1.01	Supply Sign Panel A-1	1	EA	\$5,000.00	\$5,000.00
1.02	Supply Sign Mounting Frame & Hardware	1	LS	\$2,000.00	\$2,000.00
1.03	Supply Timber Posts (10" Diam) (Qty:6)	80	LF	\$36.00	\$2,880.00
1.04	Install Timber Posts	6	EA	\$500.00	\$3,000.00
1.05	Install Sign Panel and Frame	1	LS	\$1,000.00	\$1,000.00
1.06	Supply and Install Post Cap	6	EA	\$350.00	\$2,100.00
1.07	Supply and Install Lashing	60	LF	\$12.00	\$720.00
1.08	Adjacent Landscape Repair/Upgrade	1	LS	\$3,000.00	\$3,000.00
				Subtotal	\$19,700.00
				16% OH&P	\$3,152.00
				Total	\$22,852.00

Directional - Road

2.01	Supply Sign Panel B-1	1	EA	\$1,400.00	\$1,400.00
2.02	Supply Sign Mounting Frame & Hardware	2	EA	\$500.00	\$1,000.00
2.03	Supply Timber Posts (10" Diam) (Qty:2)	26	LF	\$36.00	\$936.00
2.04	Install Timber Posts	2	EA	\$500.00	\$1,000.00
2.05	Install Sign Panel and Frame	1	LS	\$750.00	\$750.00
2.06	Supply and Install Post Cap	2	EA	\$350.00	\$700.00
2.07	Supply and Install Lashing	30	LF	\$12.00	\$360.00
2.08	Adjacent Landscape Repair/Upgrade	1	LS	\$1,000.00	\$1,000.00
				Subtotal	\$7,146.00
				16% OH&P	\$1,143.36
				Total	\$8,289.36

Information - Homer & Area

2.01	Supply Sign Panel C-1	1	EA	\$650.00	\$650.00
2.02	Supply Sign Panel C-2	1	EA	\$700.00	\$700.00
2.03	Supply Sign Mounting Frame & Hardware	2	LS	\$500.00	\$1,000.00
2.04	Supply Timber Post (8" diam)	19	LF	\$24.00	\$456.00
2.05	Install Sign Panel and Frame	1	LS	\$500.00	\$500.00
2.06	Supply and Install Post Cap	1	EA	\$350.00	\$350.00
2.07	Repair Surrounding Area	1	EA	\$500.00	\$500.00
				Subtotal	\$4,156.00
				16% OH&P	\$664.96
				Total	\$4,820.96

Directional - Post

4.01	Supply Sign Panel - Direction D-1	8	EA	\$125.00	\$1,000.00
4.02	Supply Sign Panel - Neighborhood D-2	1	EA	\$275.00	\$275.00
4.03	Supply Sign Mounting Frame & Hardware	4	EA	\$500.00	\$2,000.00
4.04	Supply Timber Post (8x8)	21	LF	\$55.00	\$1,155.00
4.05	Install Sign Panels and Frames	4	EA	\$200.00	\$800.00
4.06	Supply and Install Post Cap	1	EA	\$200.00	\$200.00
4.07	Repair Surrounding Area	1	EA	\$500.00	\$500.00
				Subtotal	\$5,930.00
				16% OH&P	\$948.80
				Total	\$6,878.80

Directional - Bollard

5.01	Supply Sign Panels E-1	4	EA	\$150.00	\$600.00
5.02	Supply Timber Post (6x6)	9	LF	\$30.00	\$270.00
5.03	Install Sign Panels	4	EA	\$100.00	\$400.00
5.04	Supply and Install Post Cap	1	EA	\$200.00	\$200.00
5.05	Repair Surrounding Area	1	EA	\$500.00	\$500.00
				Subtotal	\$1,970.00
				16% OH&P	\$315.20
				Total	\$2,285.20

Destination

6.01	Supply Sign Panels F-1	1	EA	\$200.00	\$200.00
6.02	Supply Timber Post (8x8)	13	LF	\$55.00	\$715.00
6.03	Install Sign Panels	1	EA	\$200.00	\$200.00
6.04	Supply and Install Post Cap	1	EA	\$200.00	\$200.00
6.05	Repair Surrounding Area	1	EA	\$500.00	\$500.00
				Subtotal	\$1,815.00
				16% OH&P	\$290.40
				Total	\$2,105.40

Costs were developed January 2022. Costing resources included iZone Imaging (high-pressure laminate panels), Next Innovatons (digitally fused aluminum panels), and Icy Straits Milling and Lumber. Shipping costs are included proportionally within the associated unit costs. This estimation is for planning purposes only, and should include updates, escalation, and contingencies appropriate to how the information will be used.